

AMP

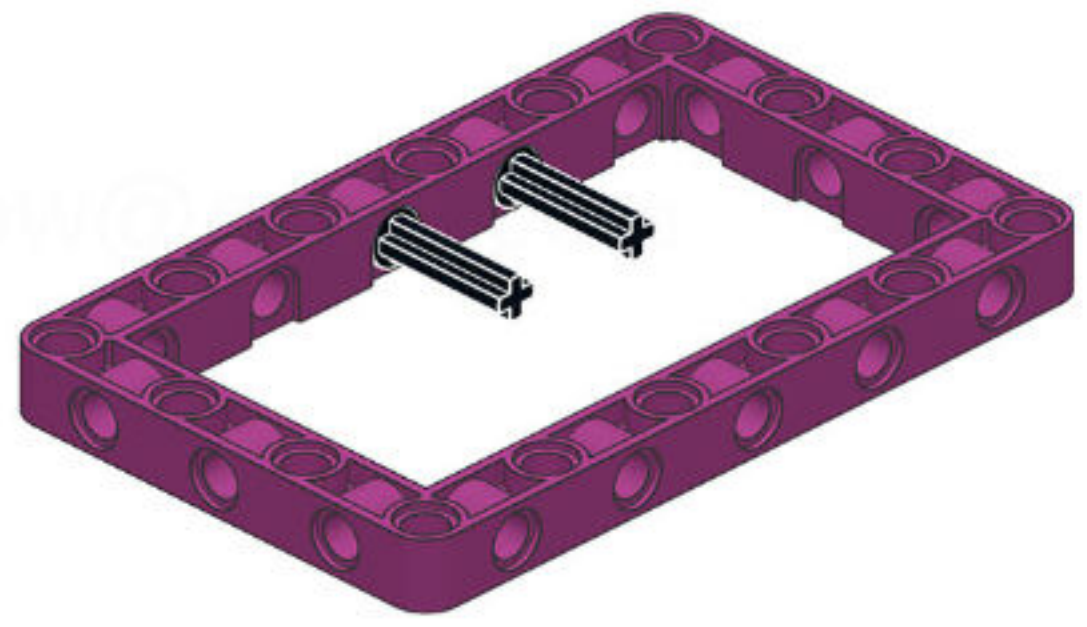
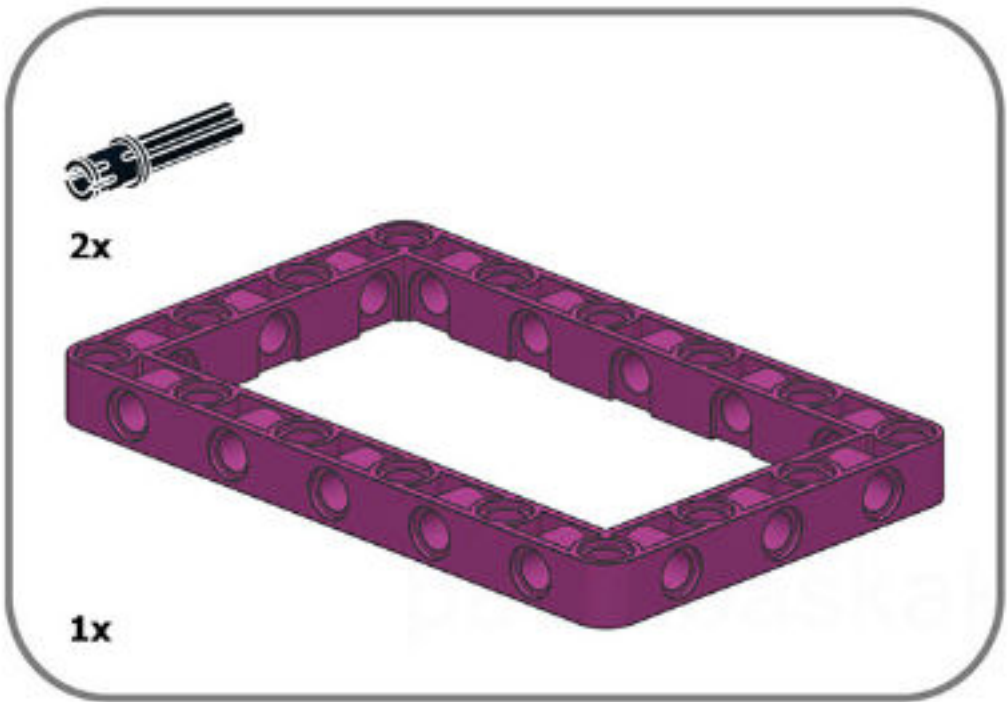

1

1/69

0

23

This block contains four hexagonal icons. The top icon shows a small assembly with the number 1/69. The second icon shows a yellow gear with the number 0. The third icon shows a red and yellow gear with the number 23. The bottom icon is partially visible and shows a red and yellow gear.

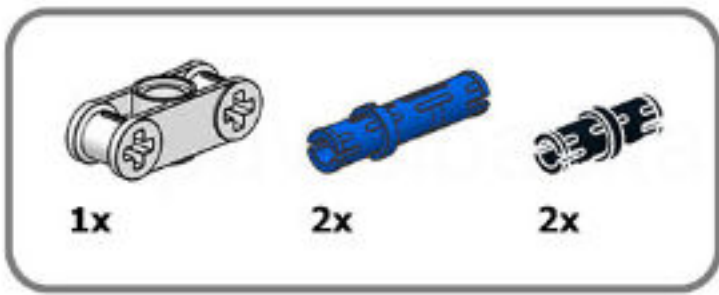

2

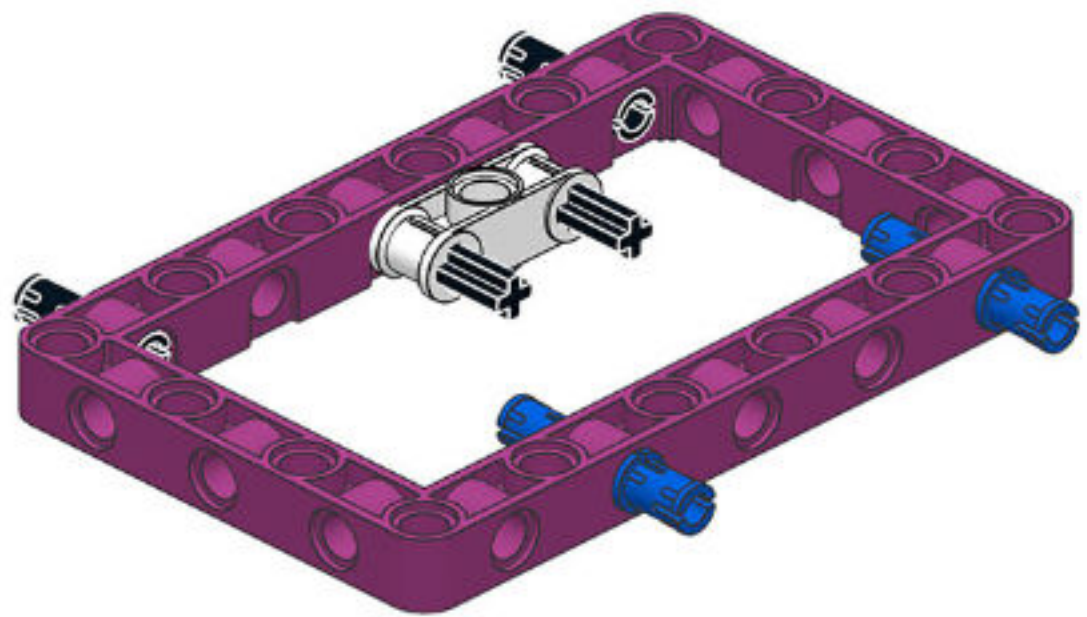

2/69

0

24

dawelbaskakow@gmail.com

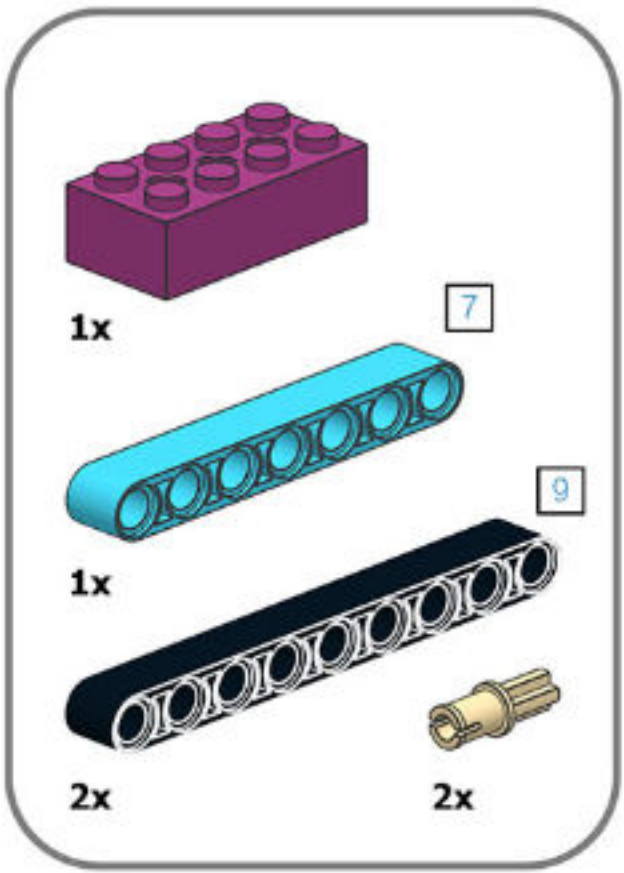

3

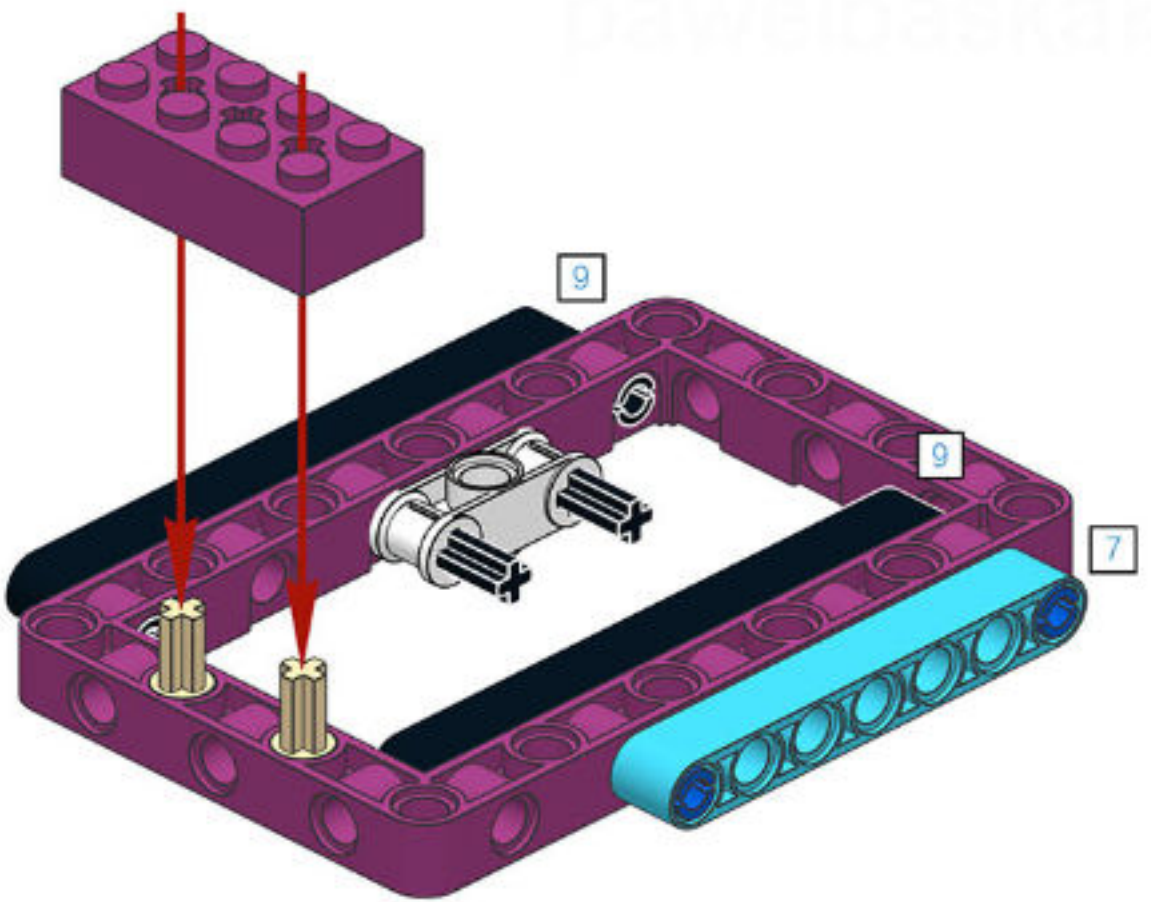

3/69

0

25

pawelbaskakow@gmail.com

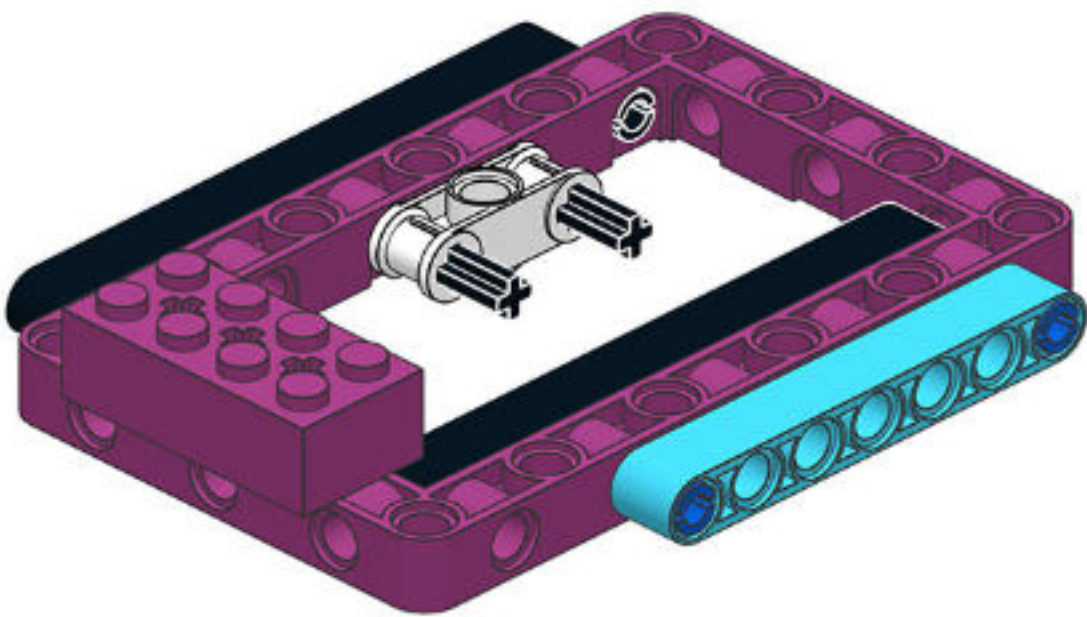

4/69

0

26

A collection of four hexagonal icons. The top one contains the text '4/69' and a small icon of a red and black triangle. The second one contains a yellow starburst icon and the number '0'. The third one contains a red and yellow circle icon. The bottom one contains the number '26'. A blue horizontal bar is positioned below these icons.

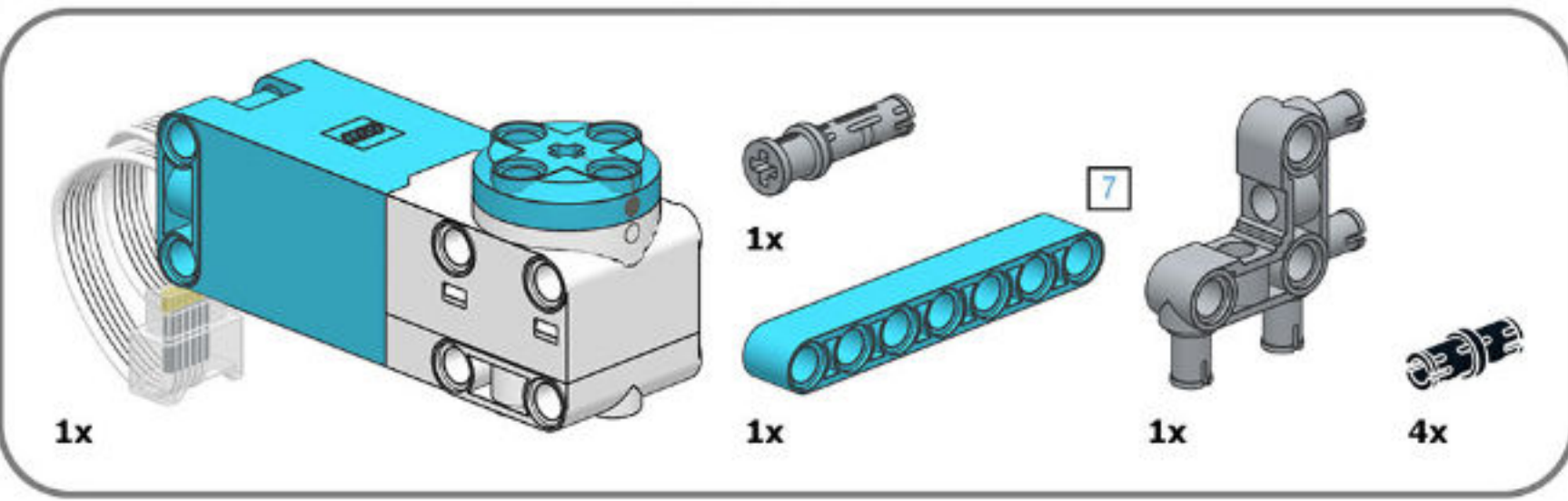
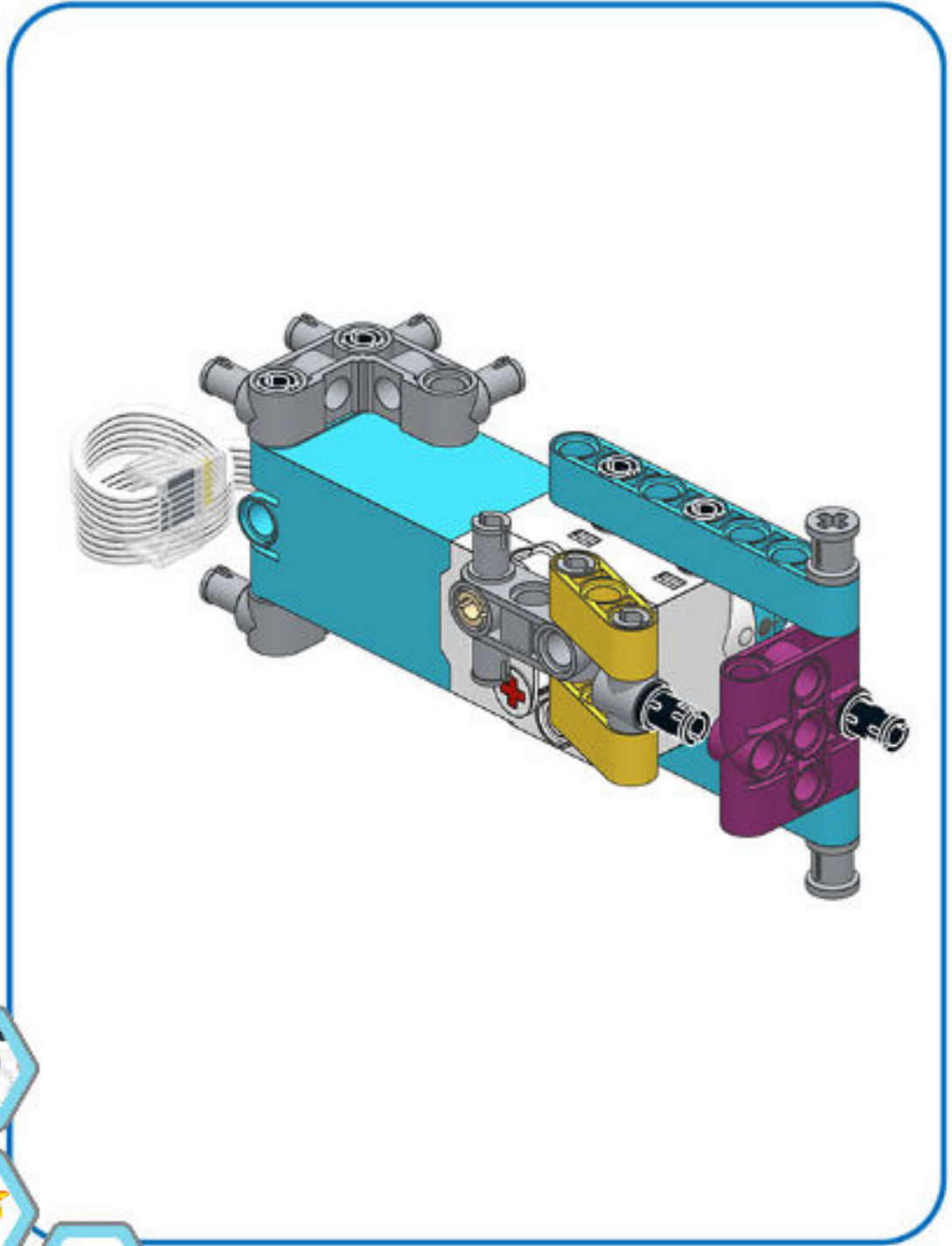

4

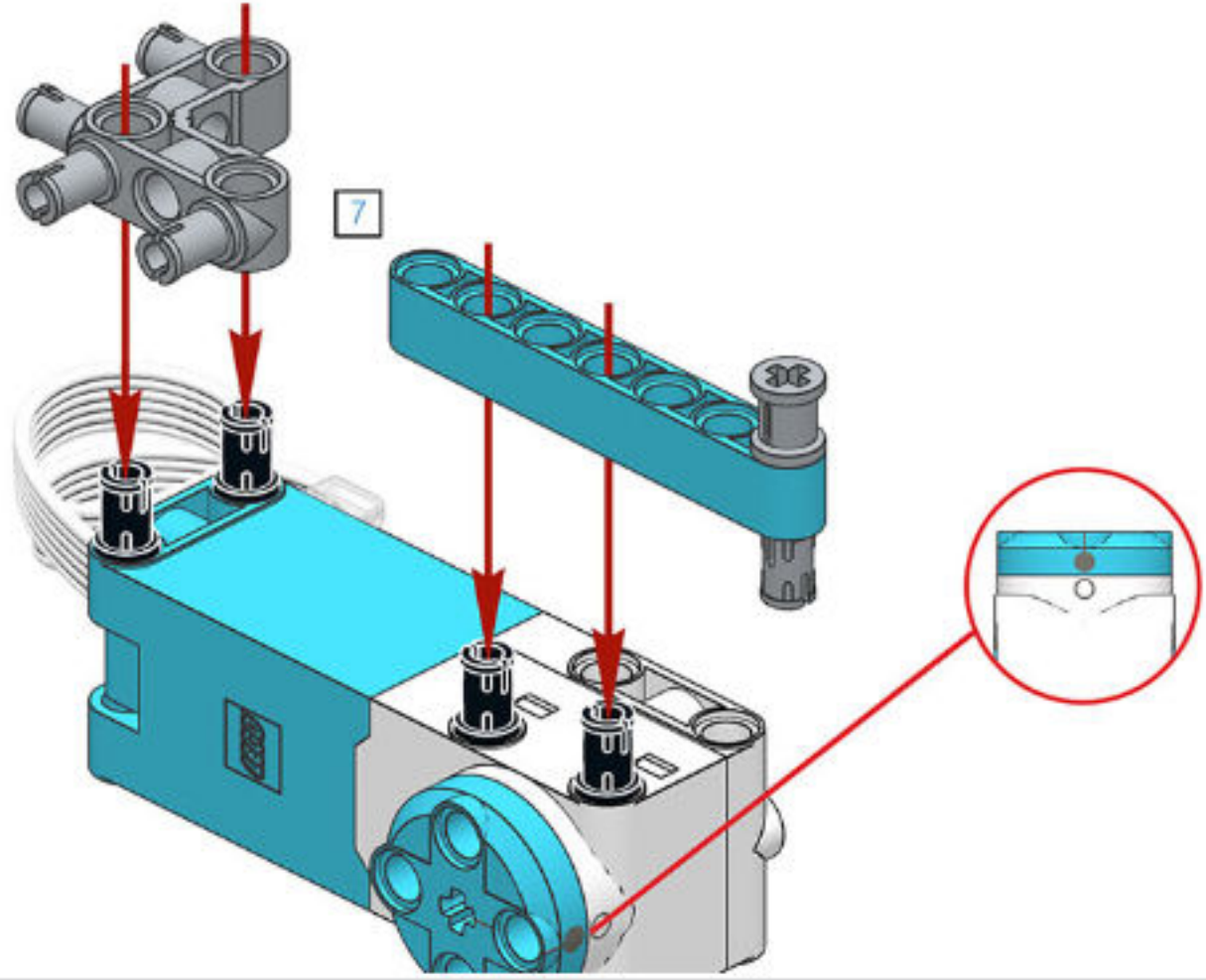

5/69
0
27

5

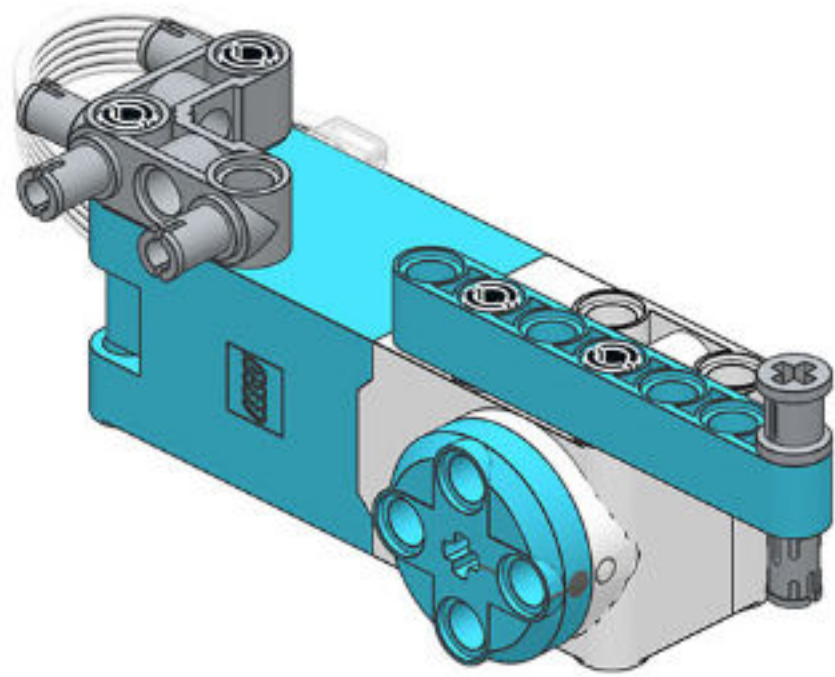

6/69

0

28

A collection of four hexagonal icons. The top one contains the text '6/69' and small symbols. Below it is a yellow starburst icon with the number '0'. To the right of the starburst is a red and yellow circle icon. At the bottom is a small grid icon with the number '28'. A blue horizontal bar is at the bottom of this section.

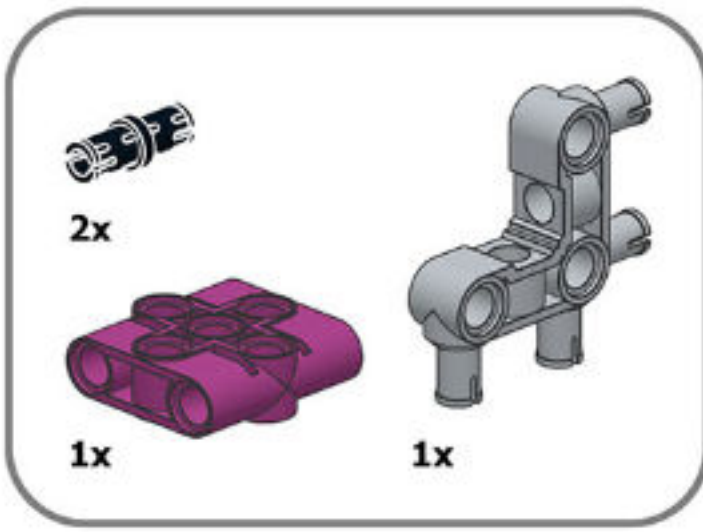

6

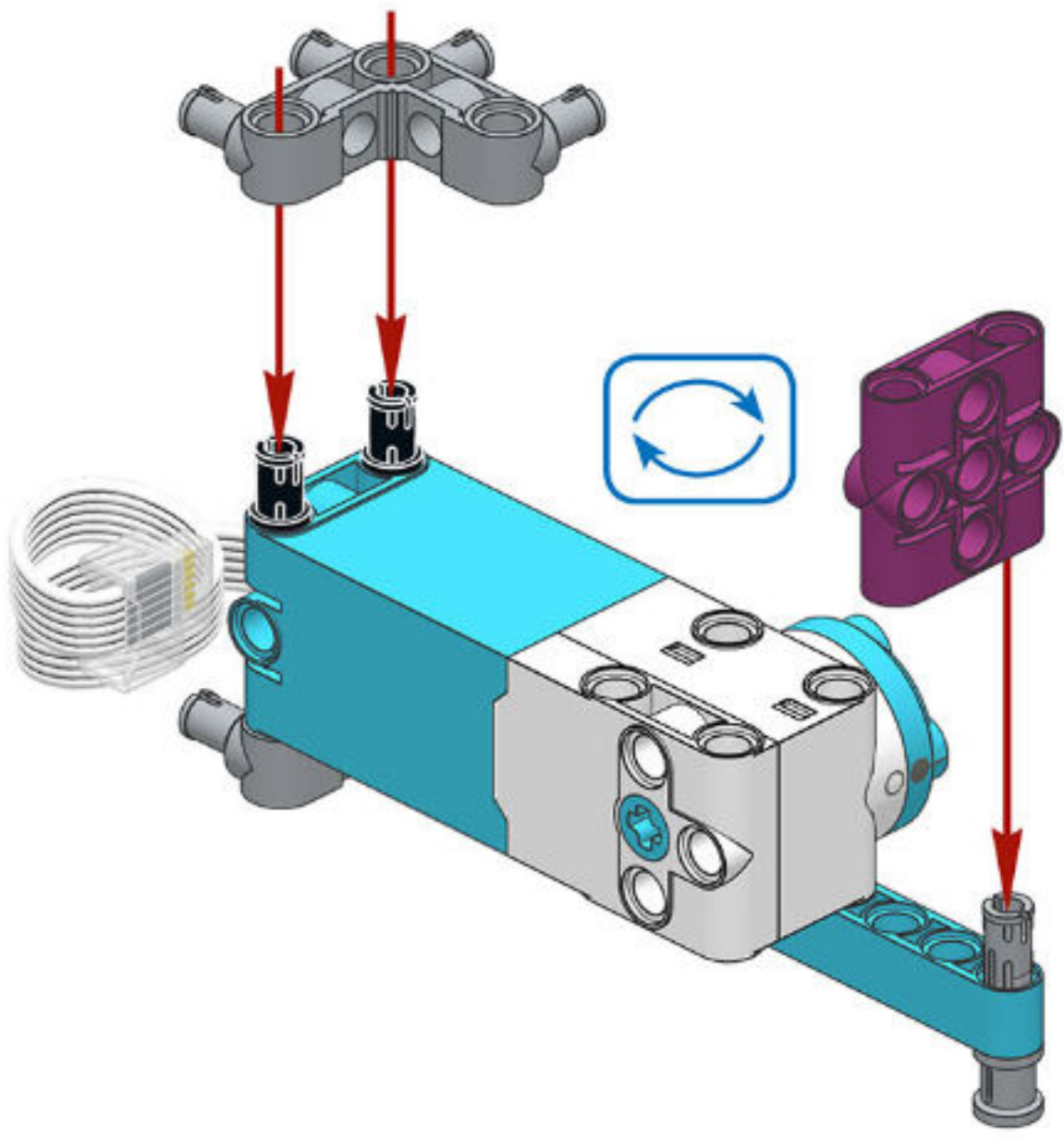

pawelbas

7/69
0
29

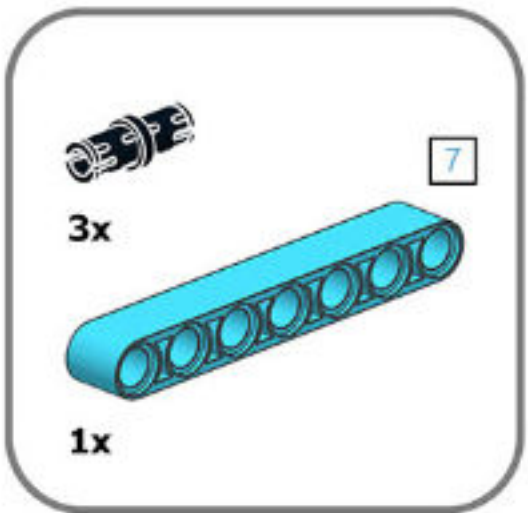

7

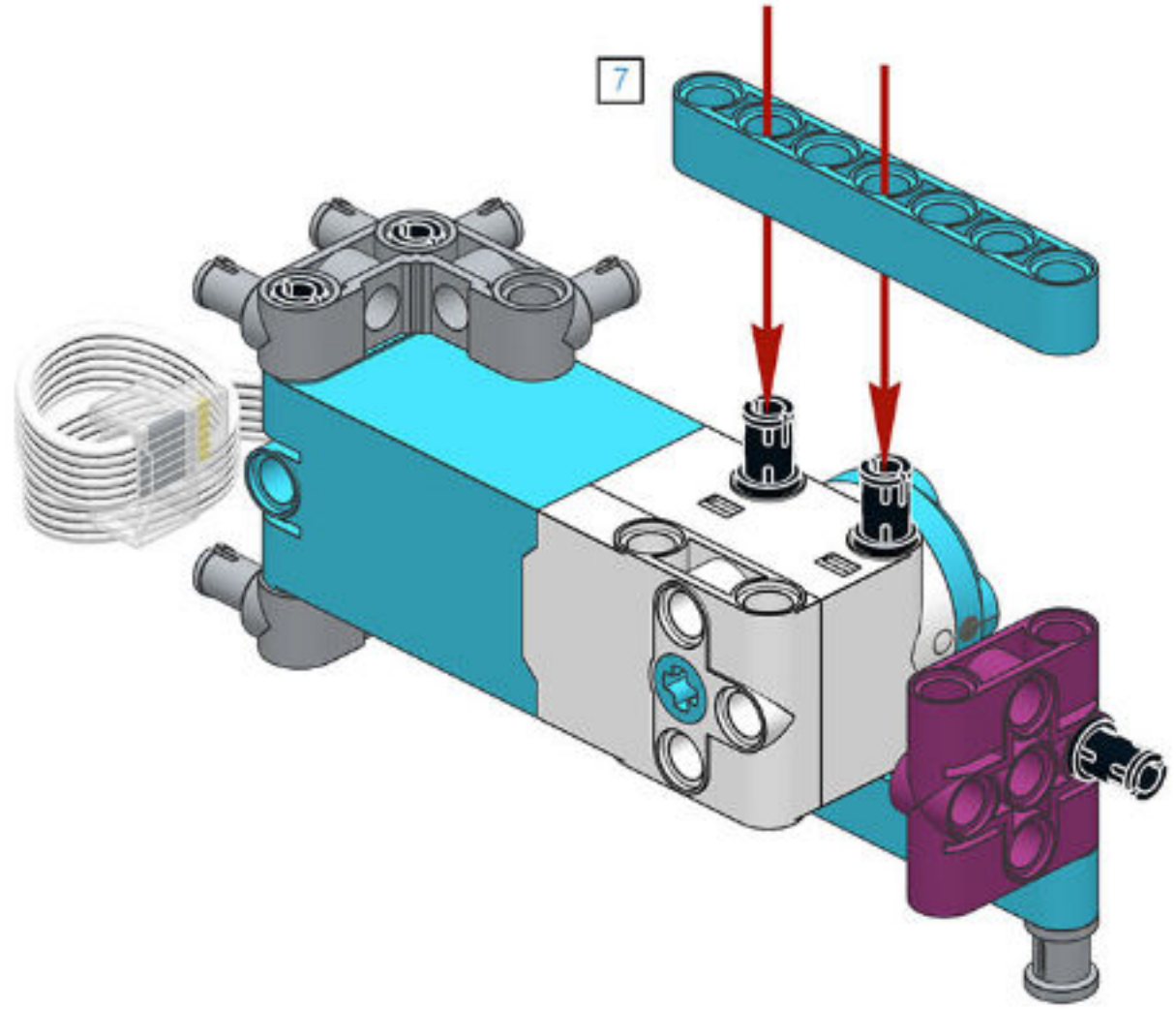

pavelbask

8/69

0

30



8

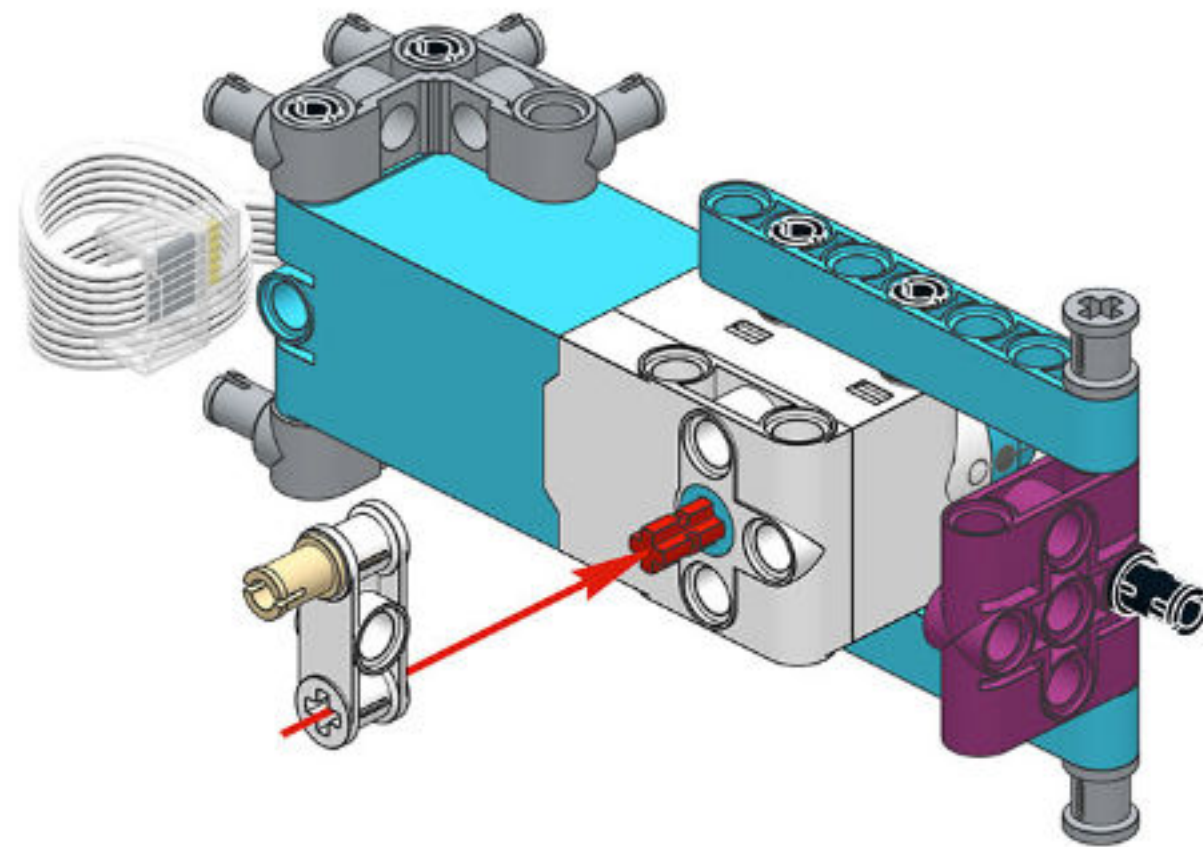

9/69

0

31

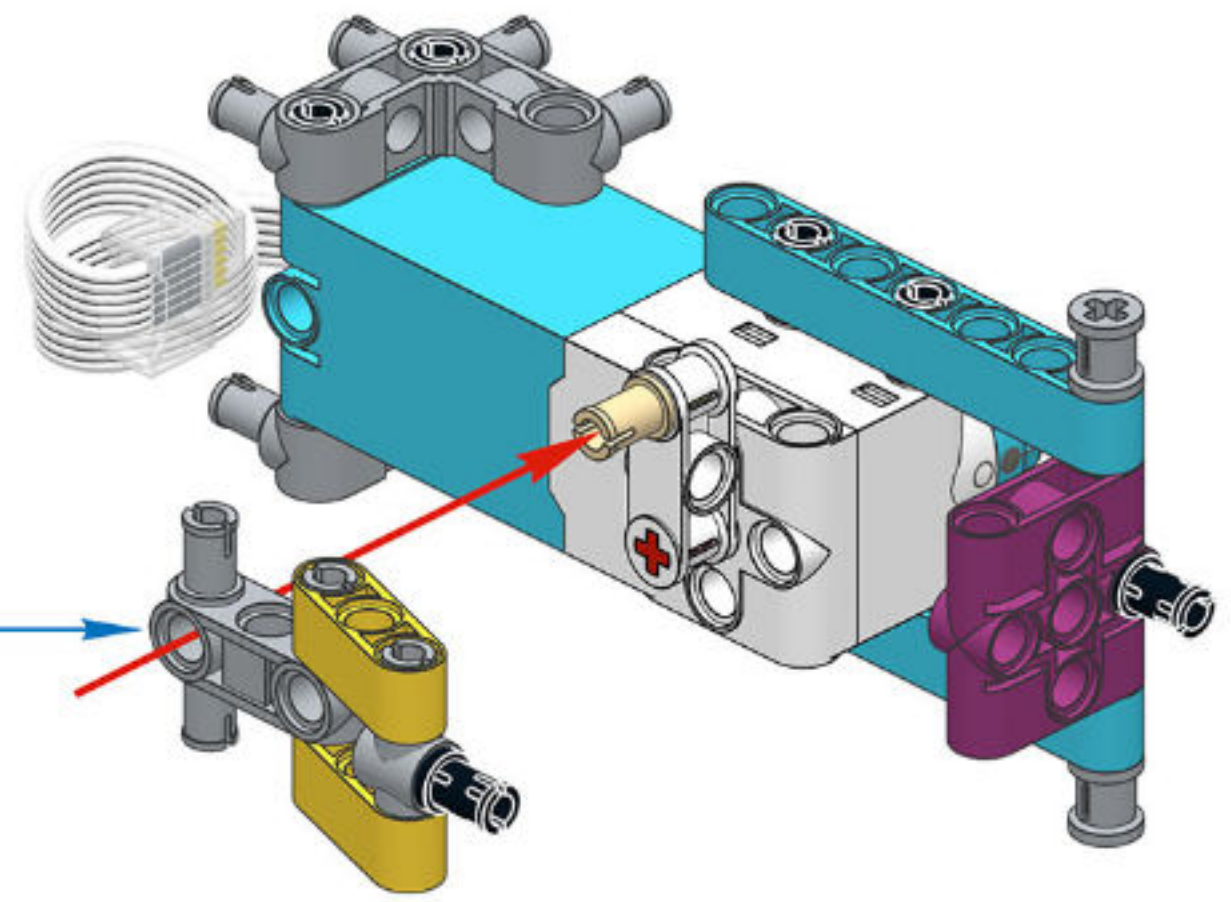
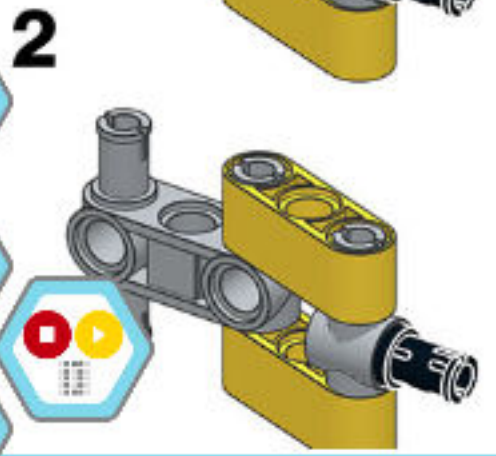
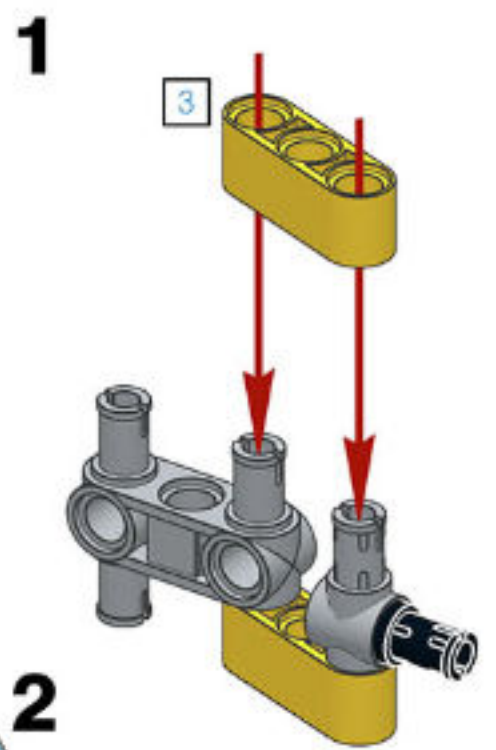
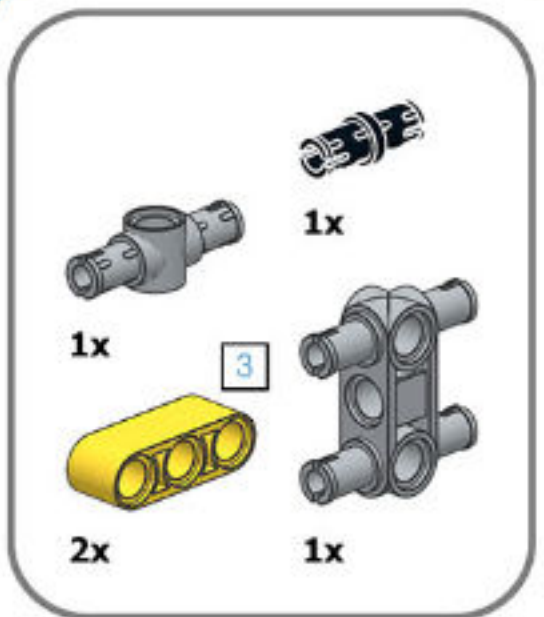

10

pawelbaskal

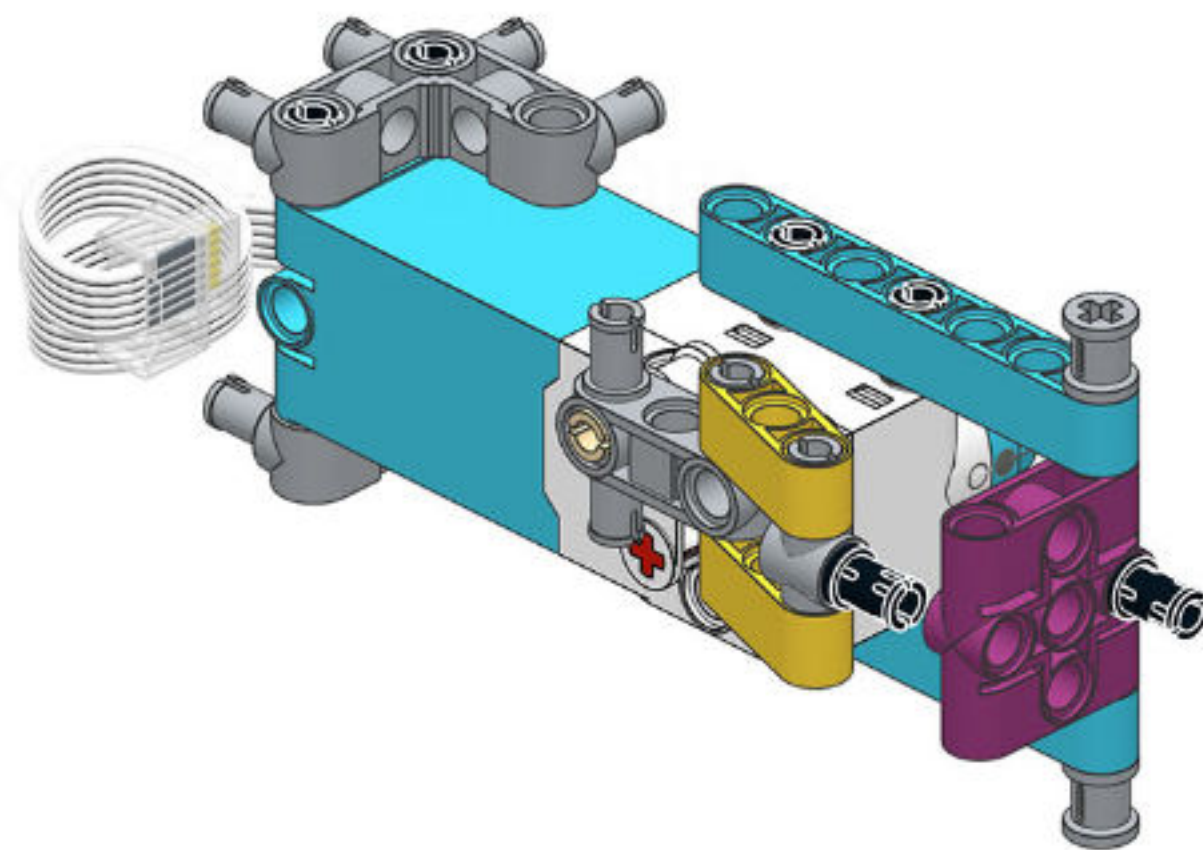

11/69

0

33



11

pawelbarto

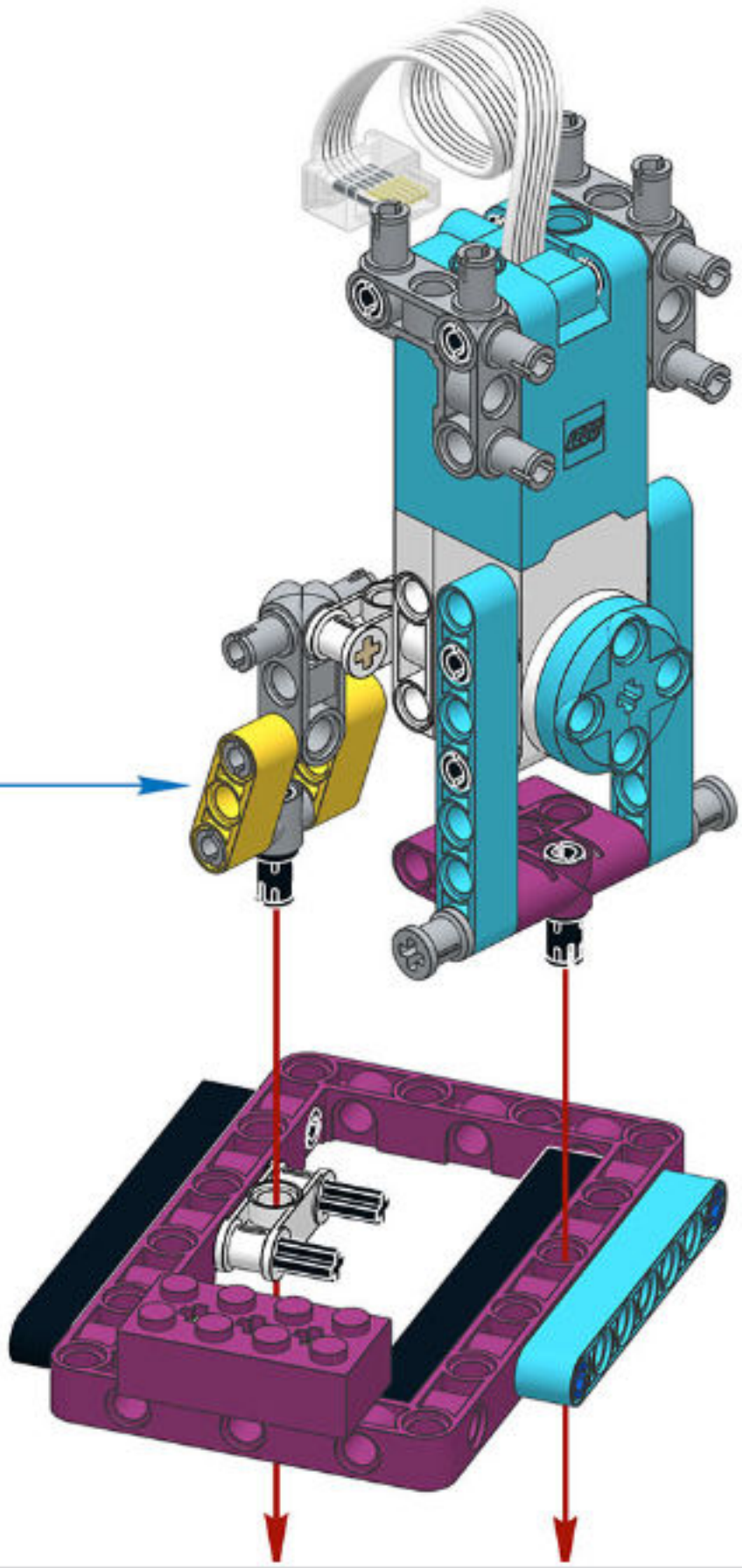

12/69

0

34

12

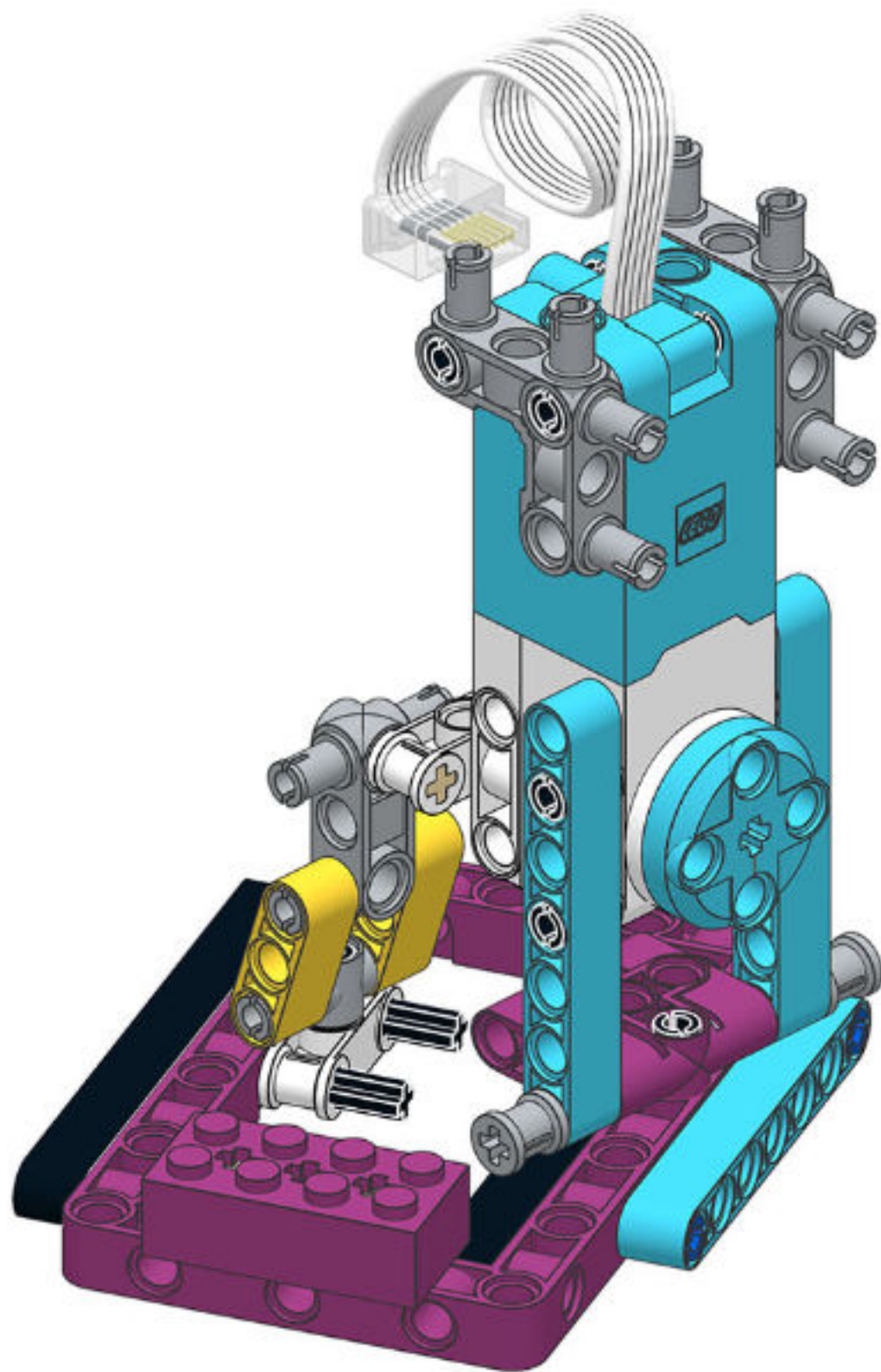

pavelbaskakov@gmail.com

13/69

0

35

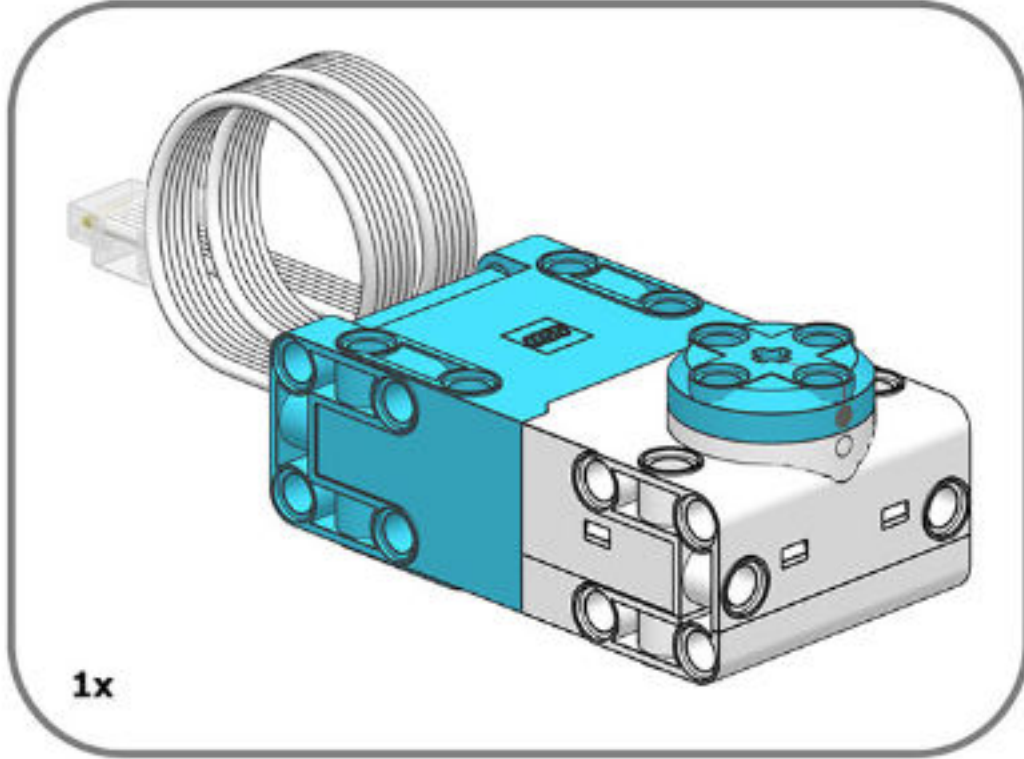

13

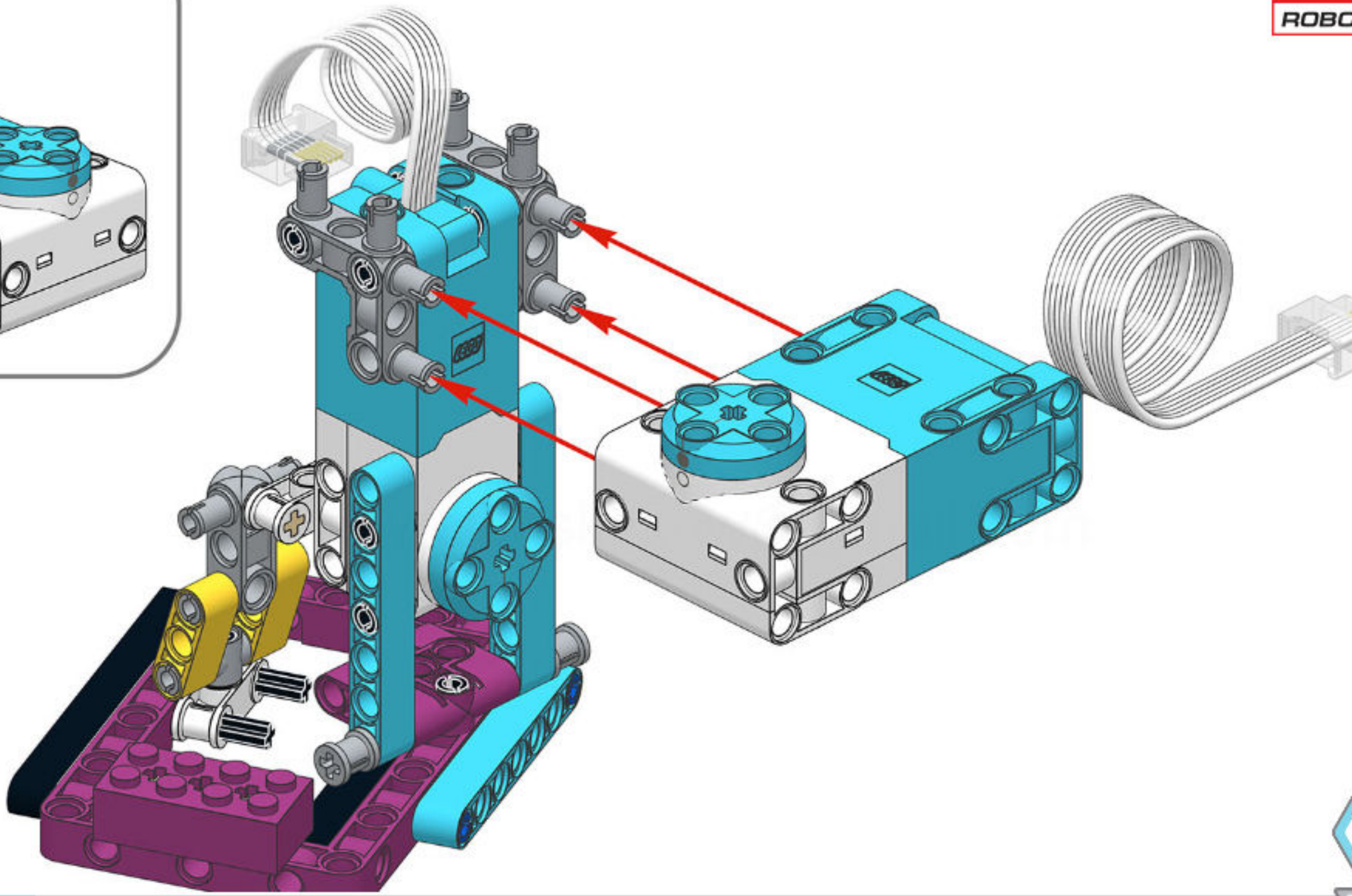

14/69

0

36

14

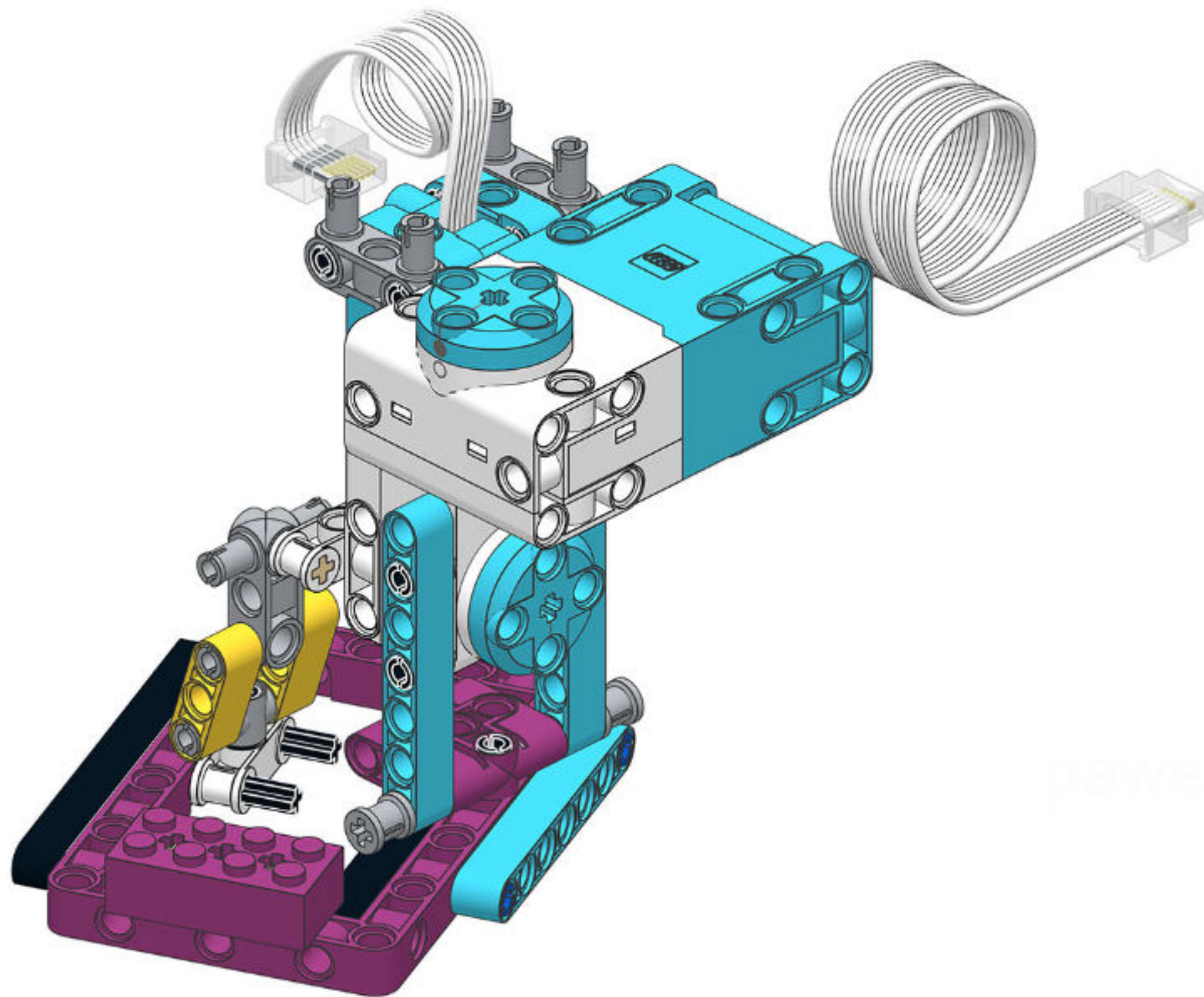

pawelbaskakow

15/69

0

37

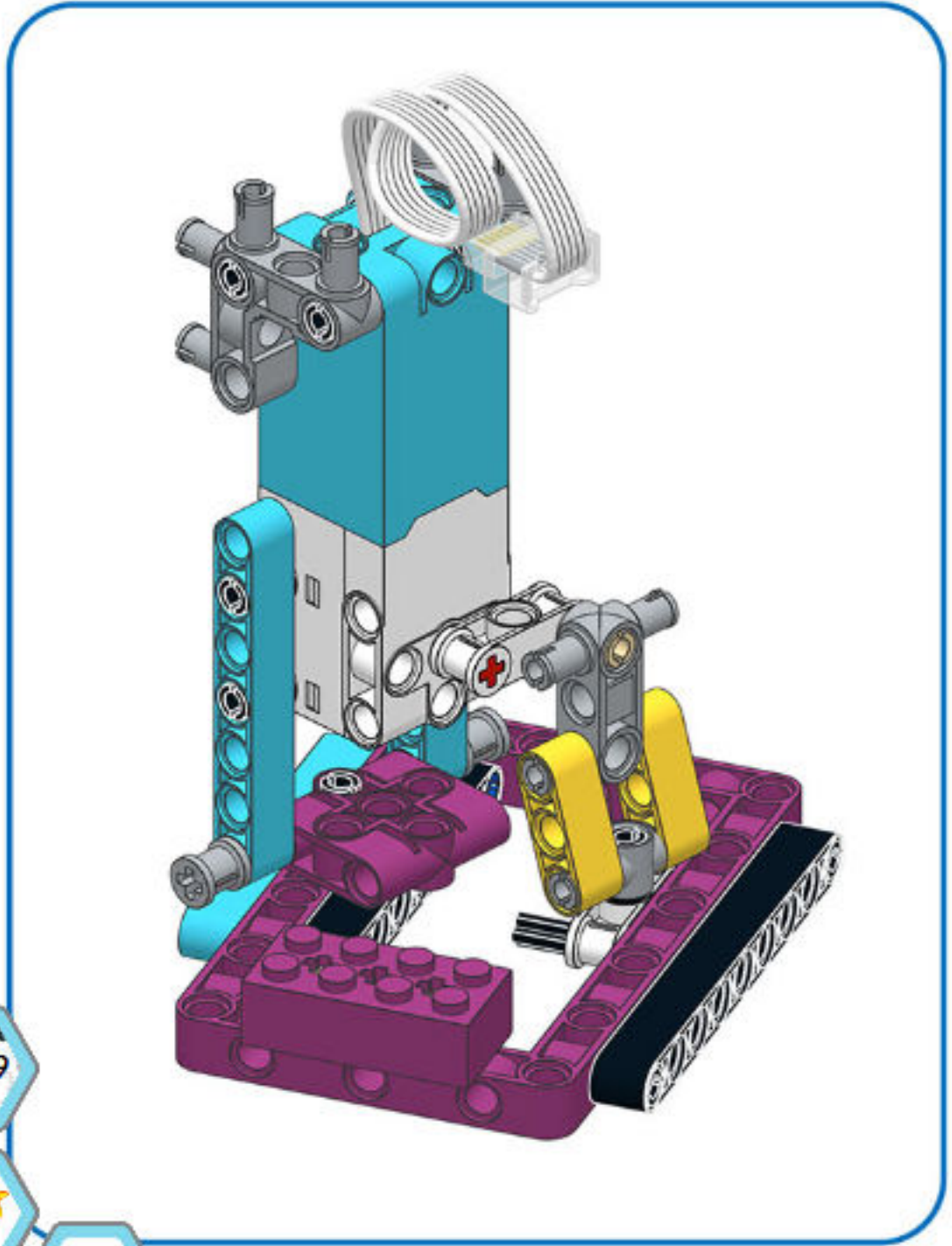

15





16

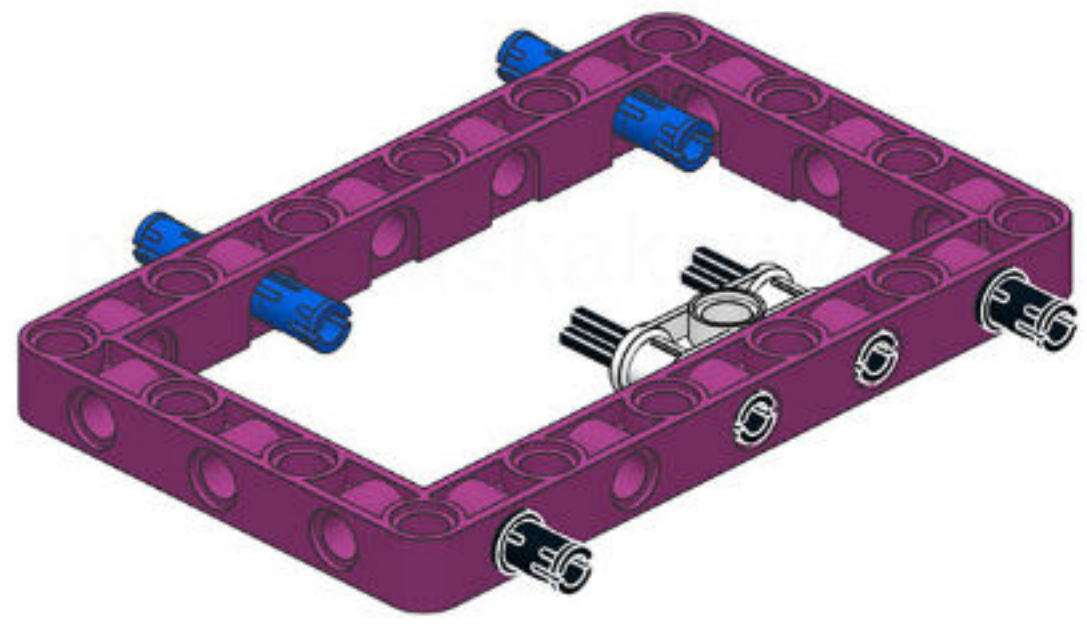

17/69

0

39

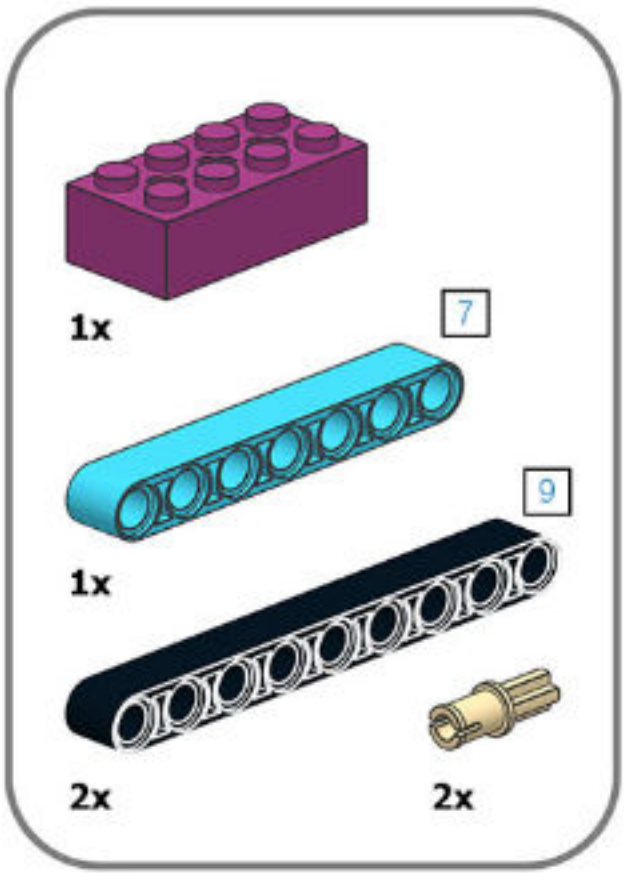

17

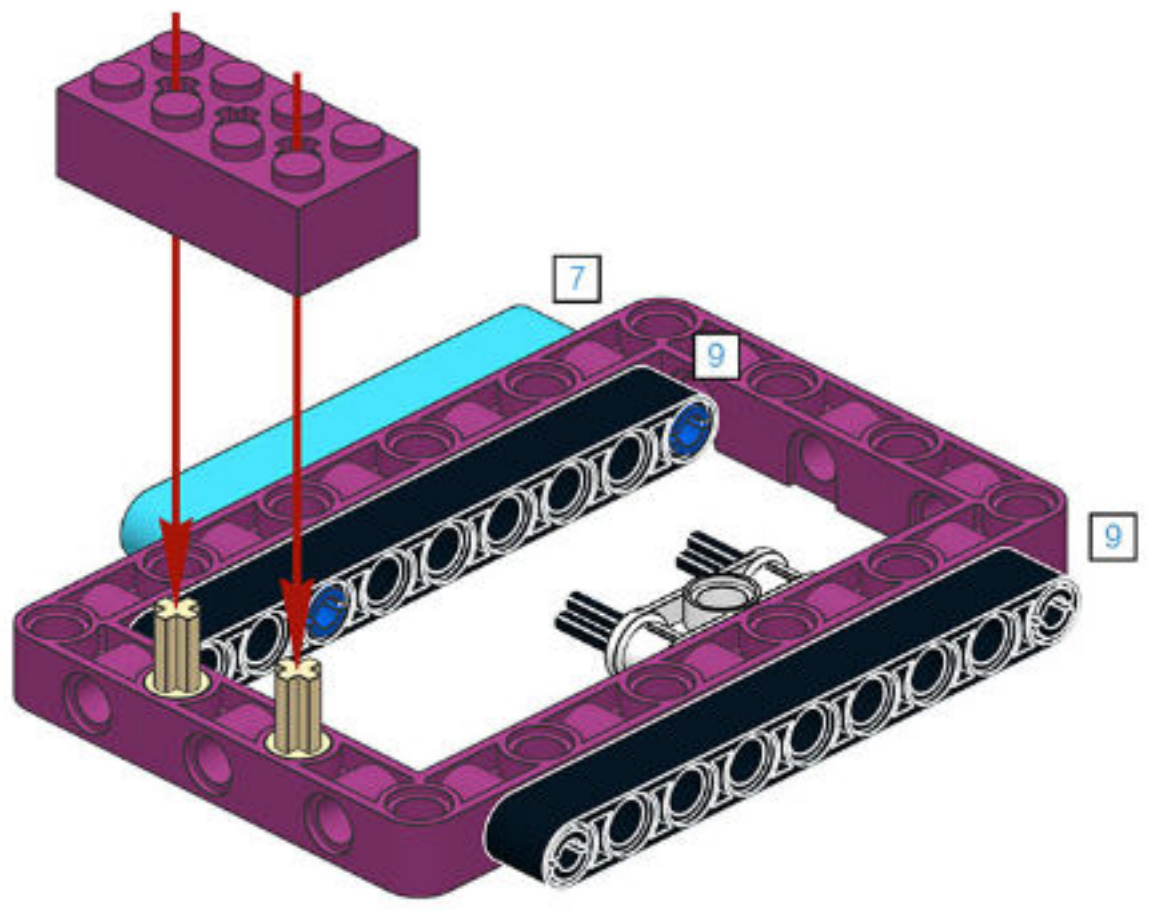

pavelbaskakov@gmail.com

18/69
0
40

18

pawelbaskakow@gmail.com

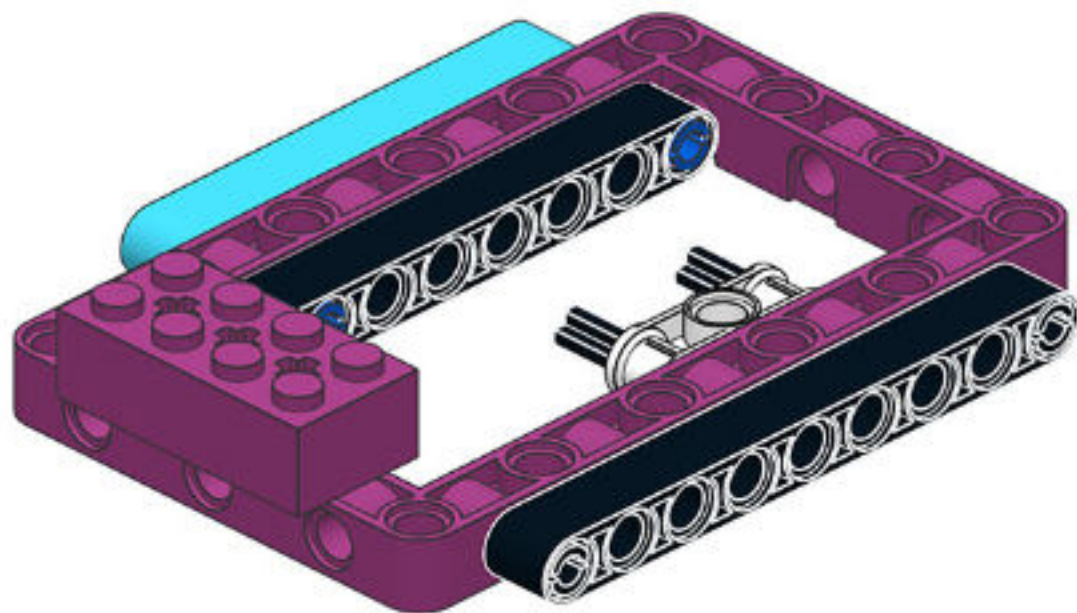

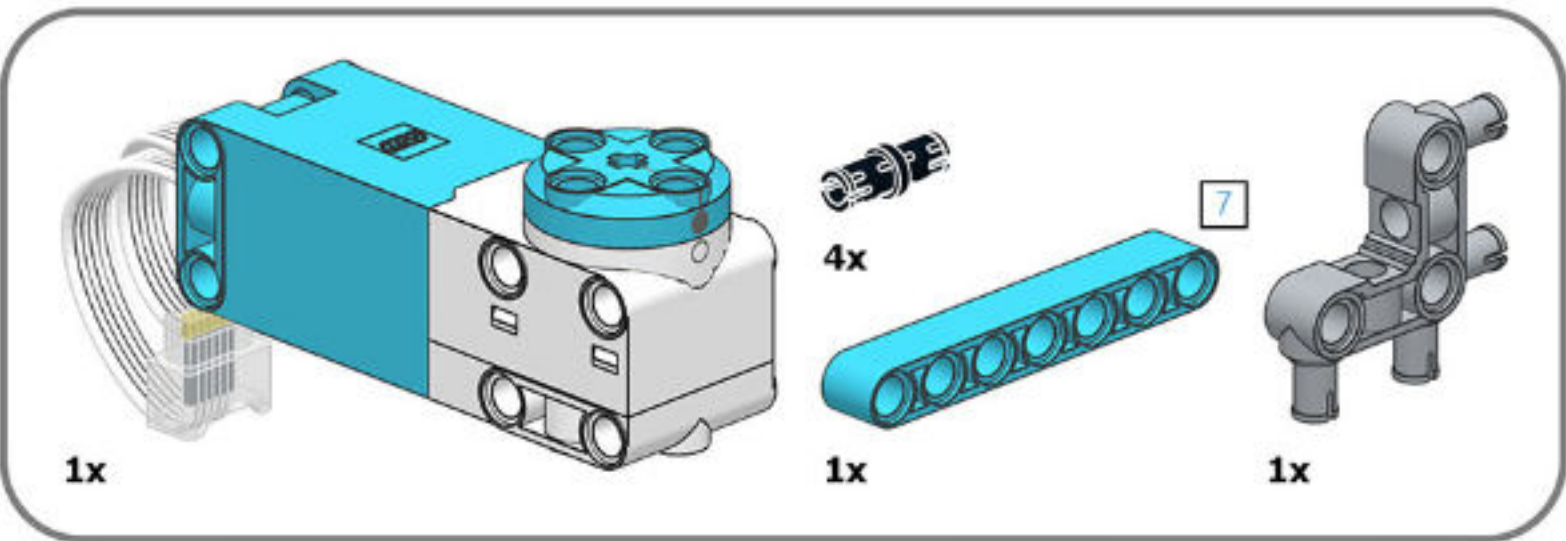
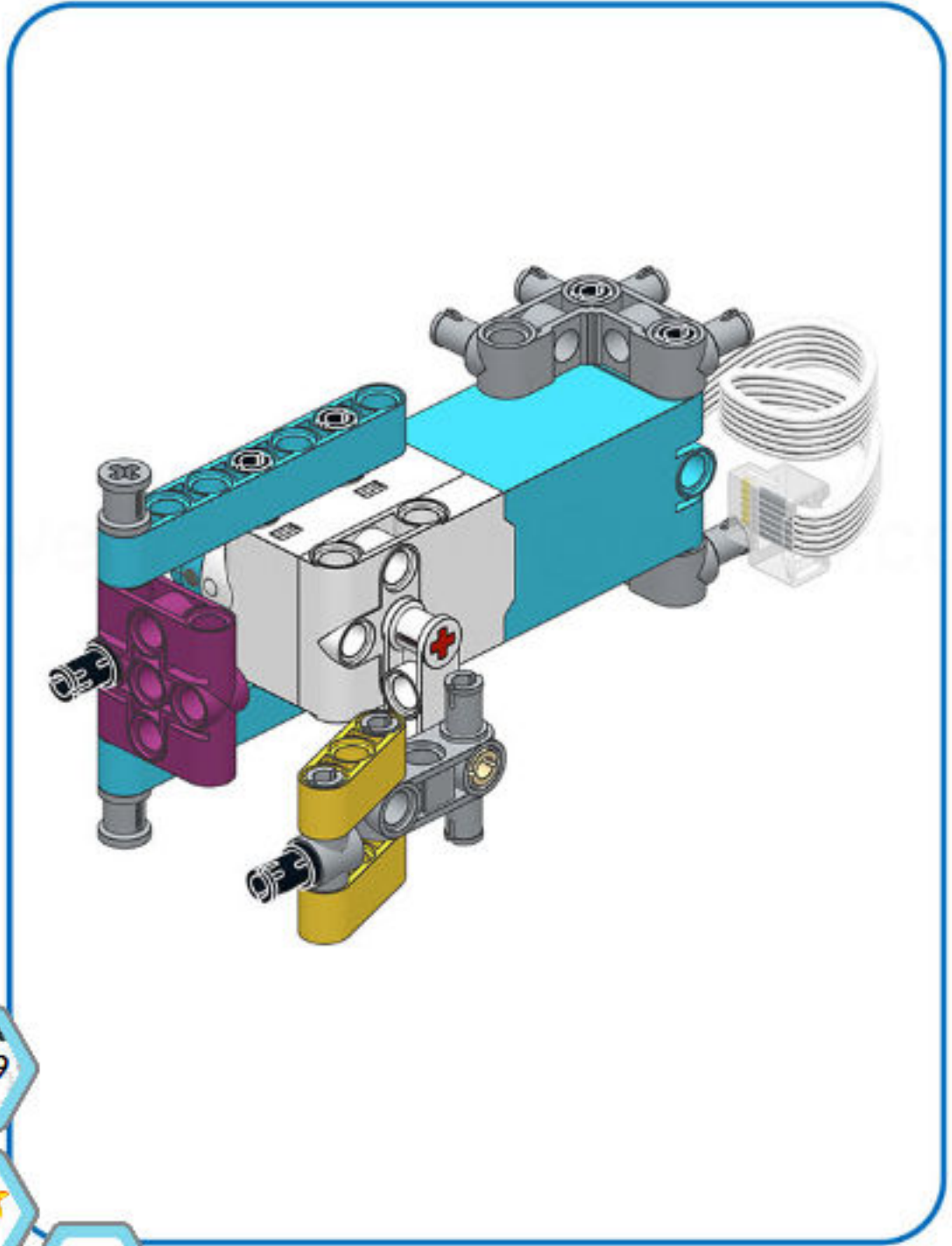

19

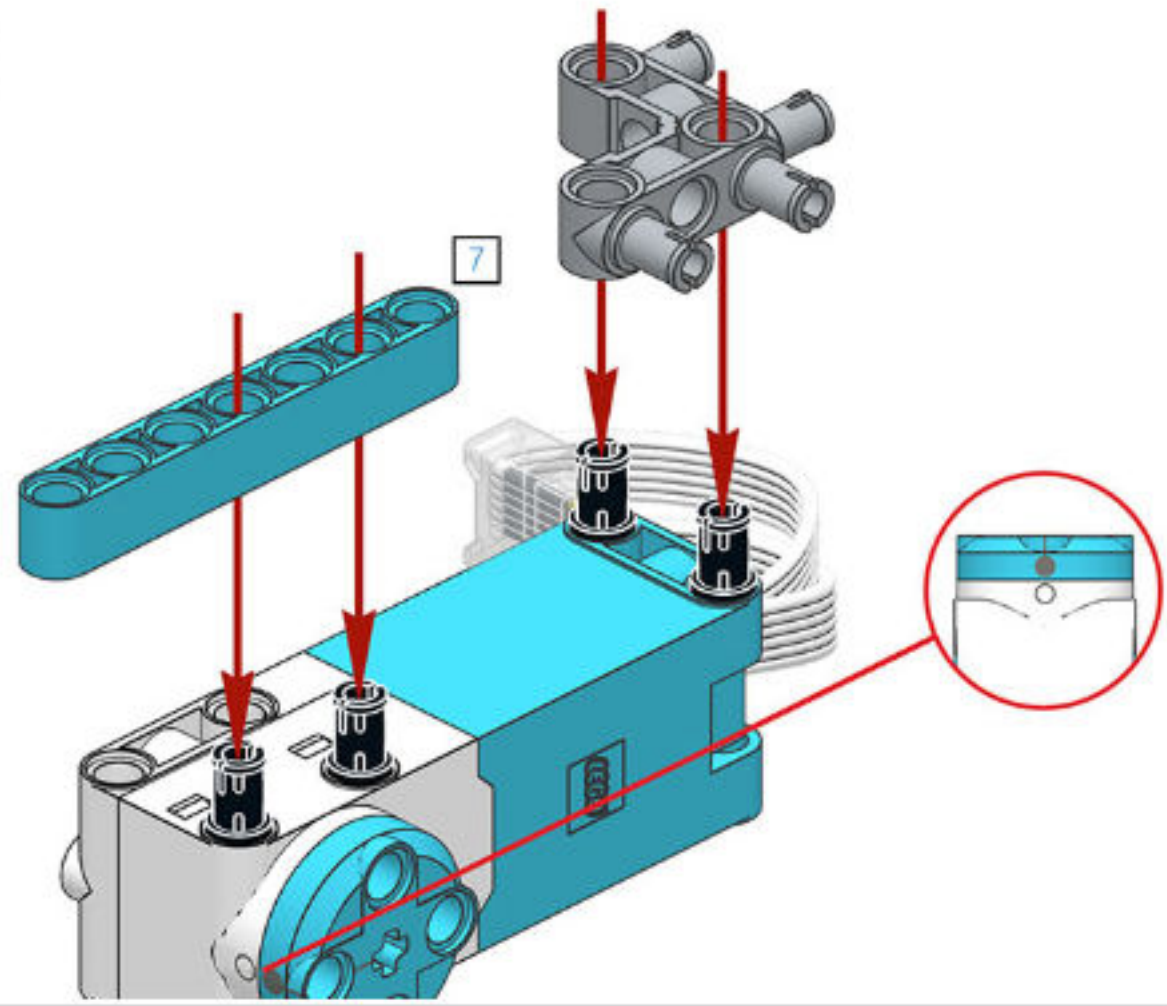

20/69

0

42

pawelbaskakov@gmail

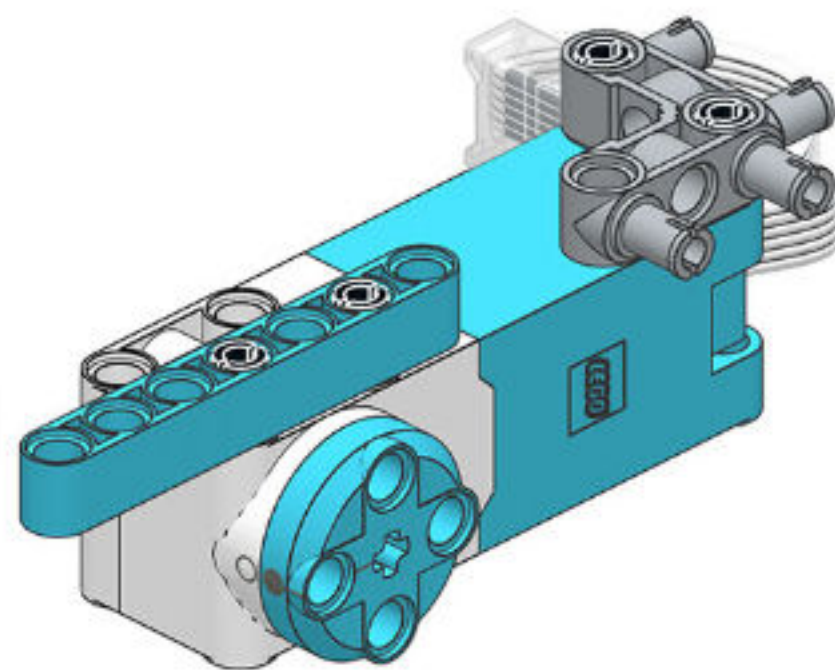

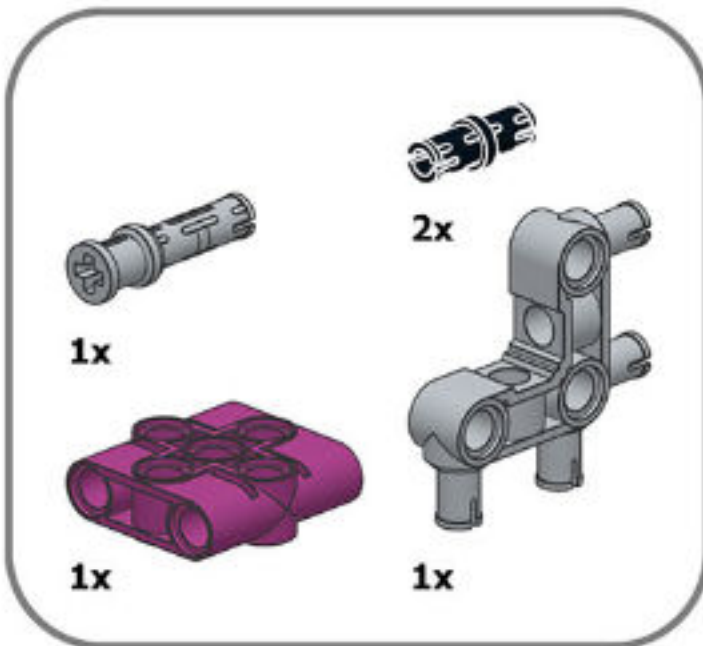

21

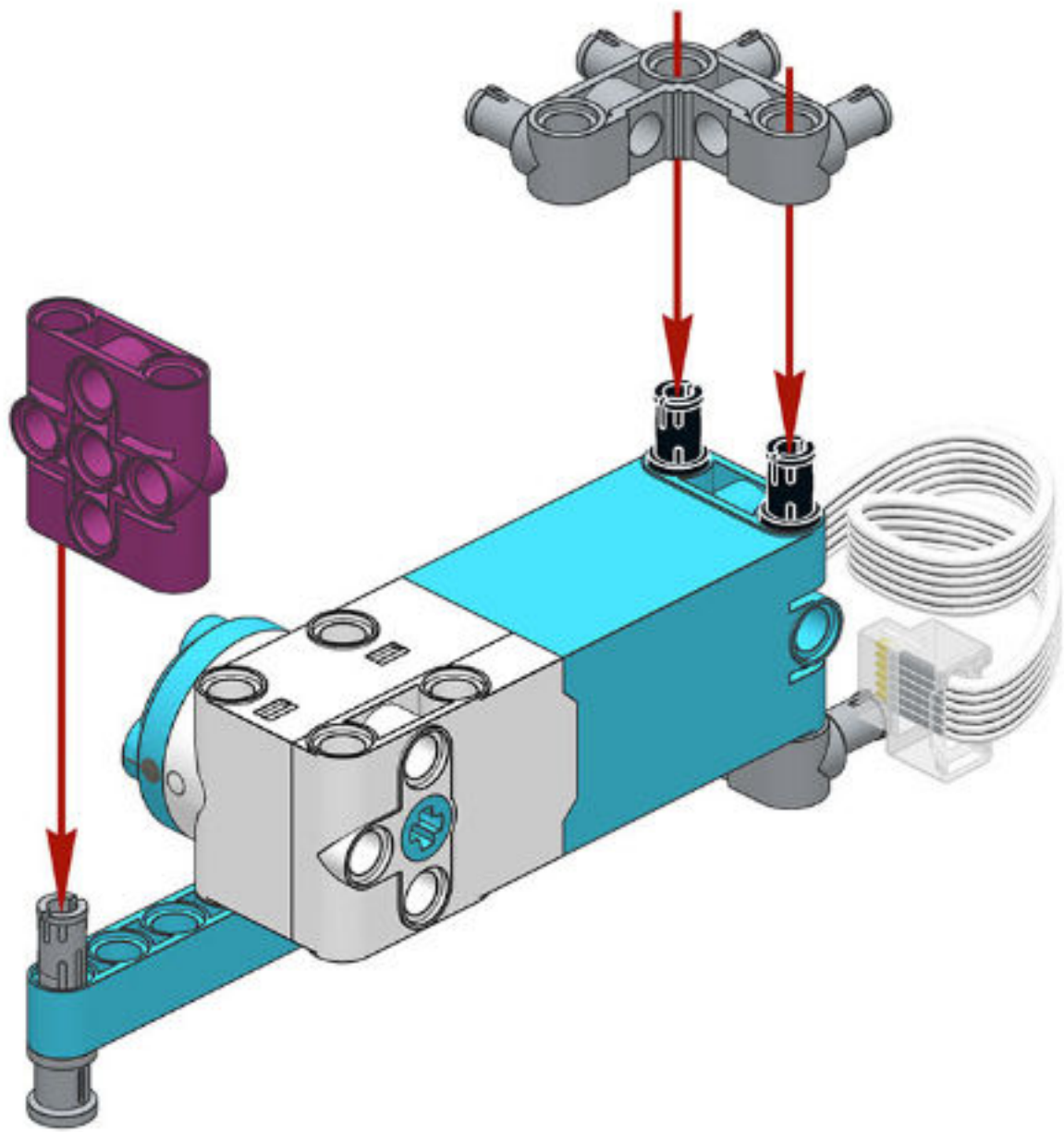

pawelbaskako

22/69
0
44

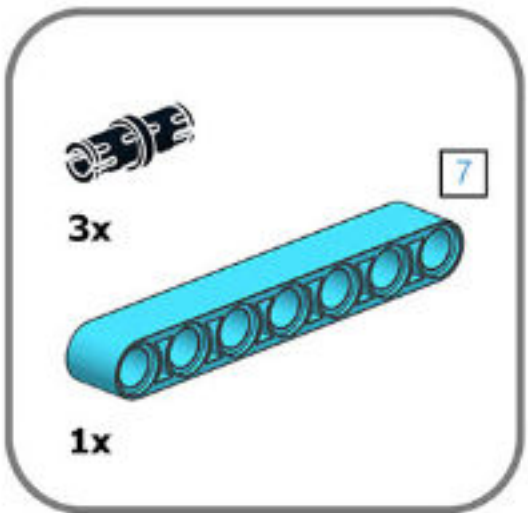

22

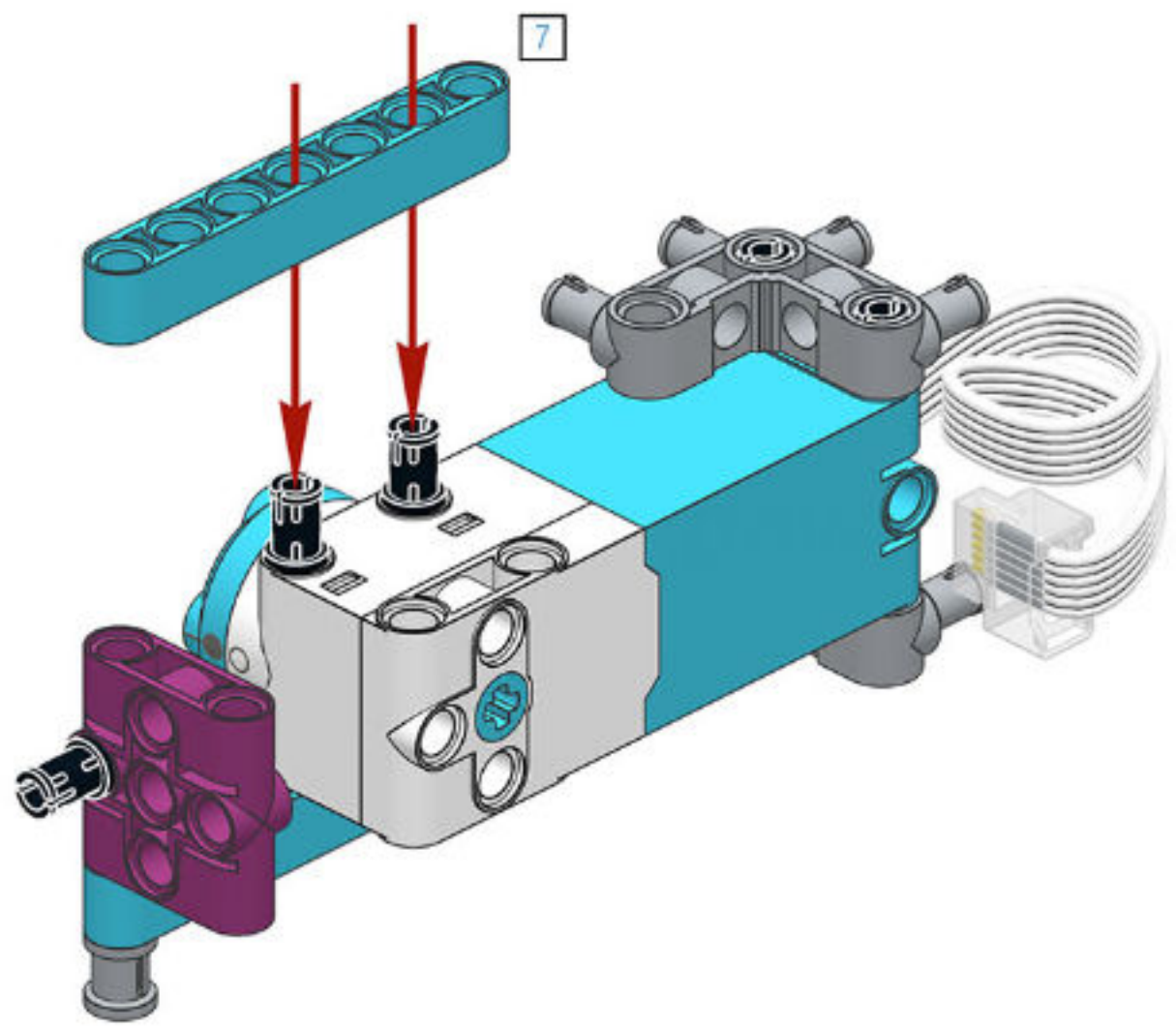

how@gmail.com

23/69

0

45



23

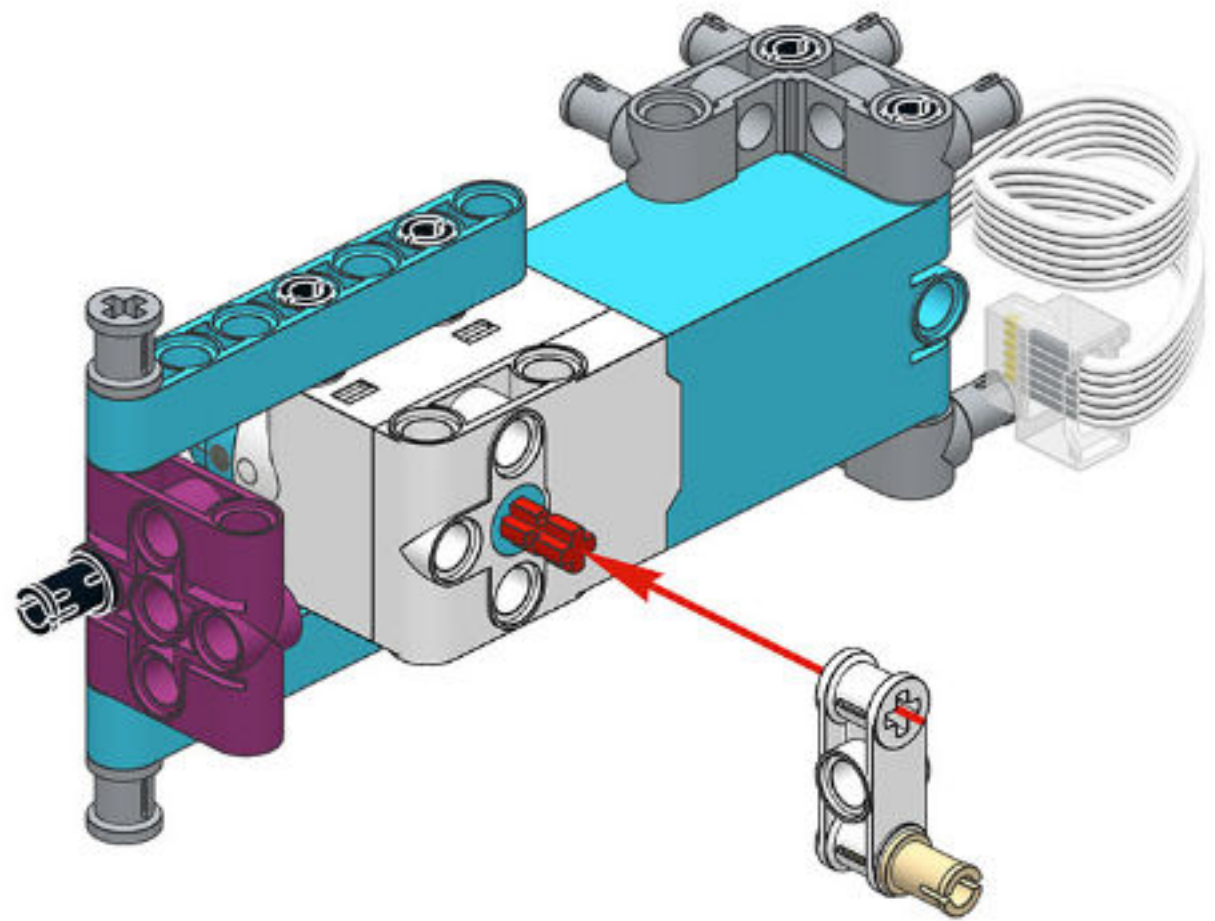

24/69
0
46

- 1x [Grey T-shaped connector]
- 1x [Black axle with stop]
- 1x [Yellow 3-hole Technic beam]
- 1x [Grey 3-way connector]

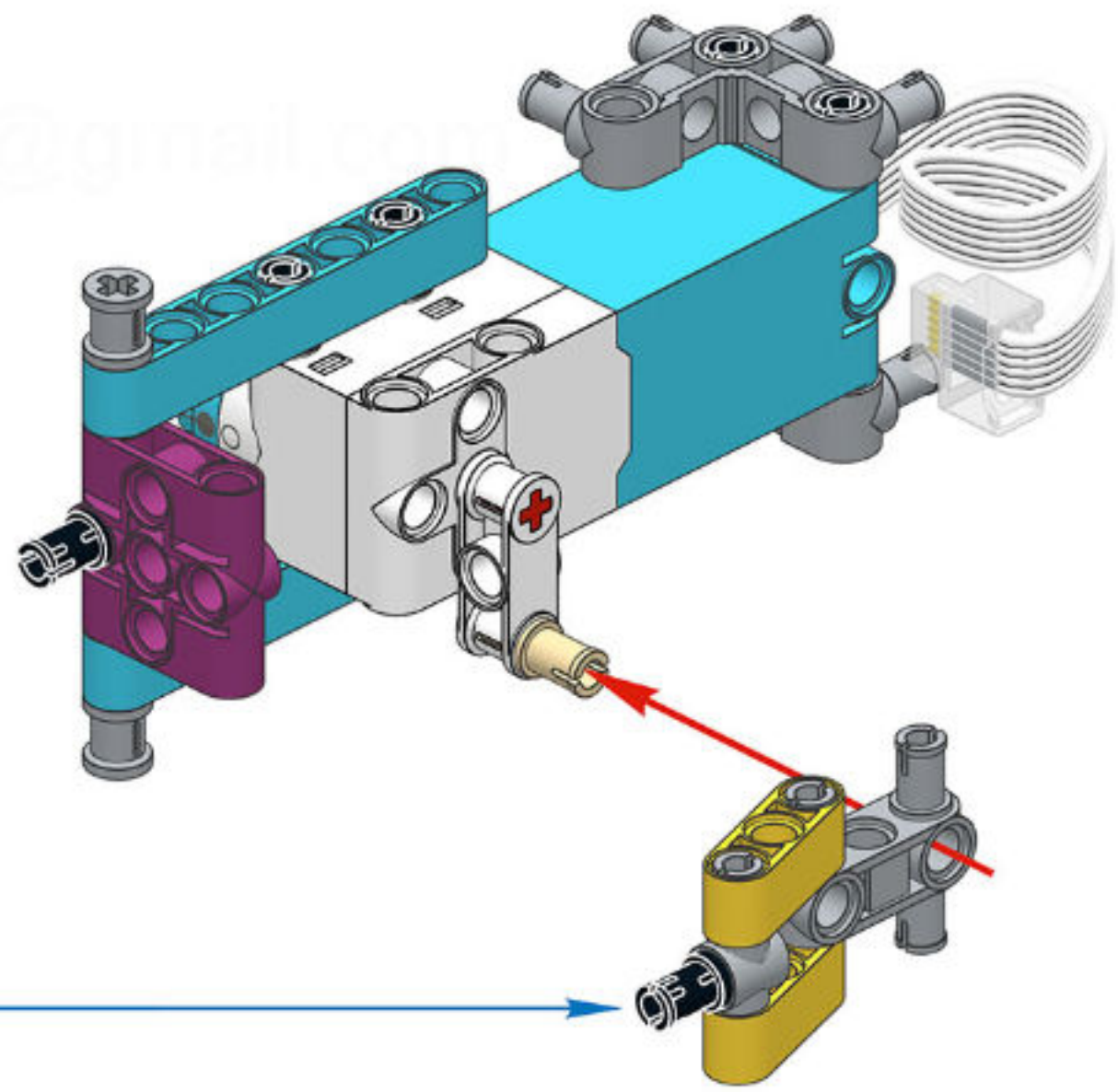
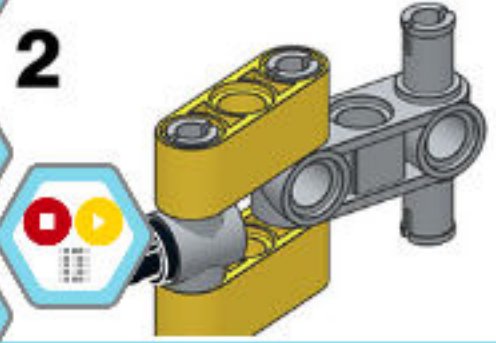
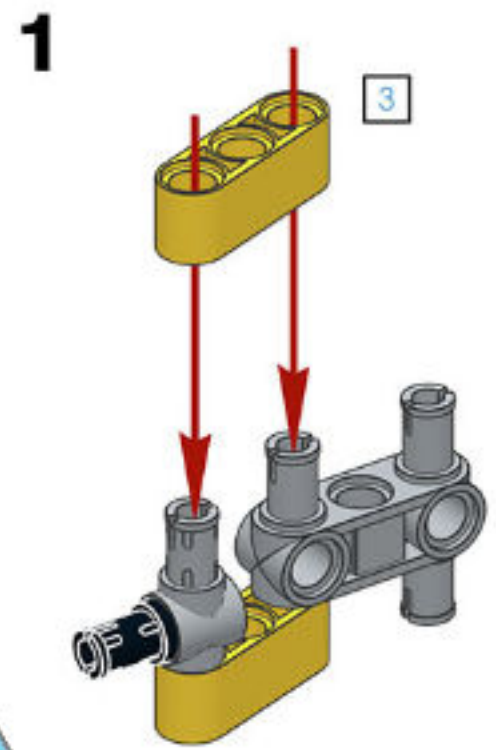

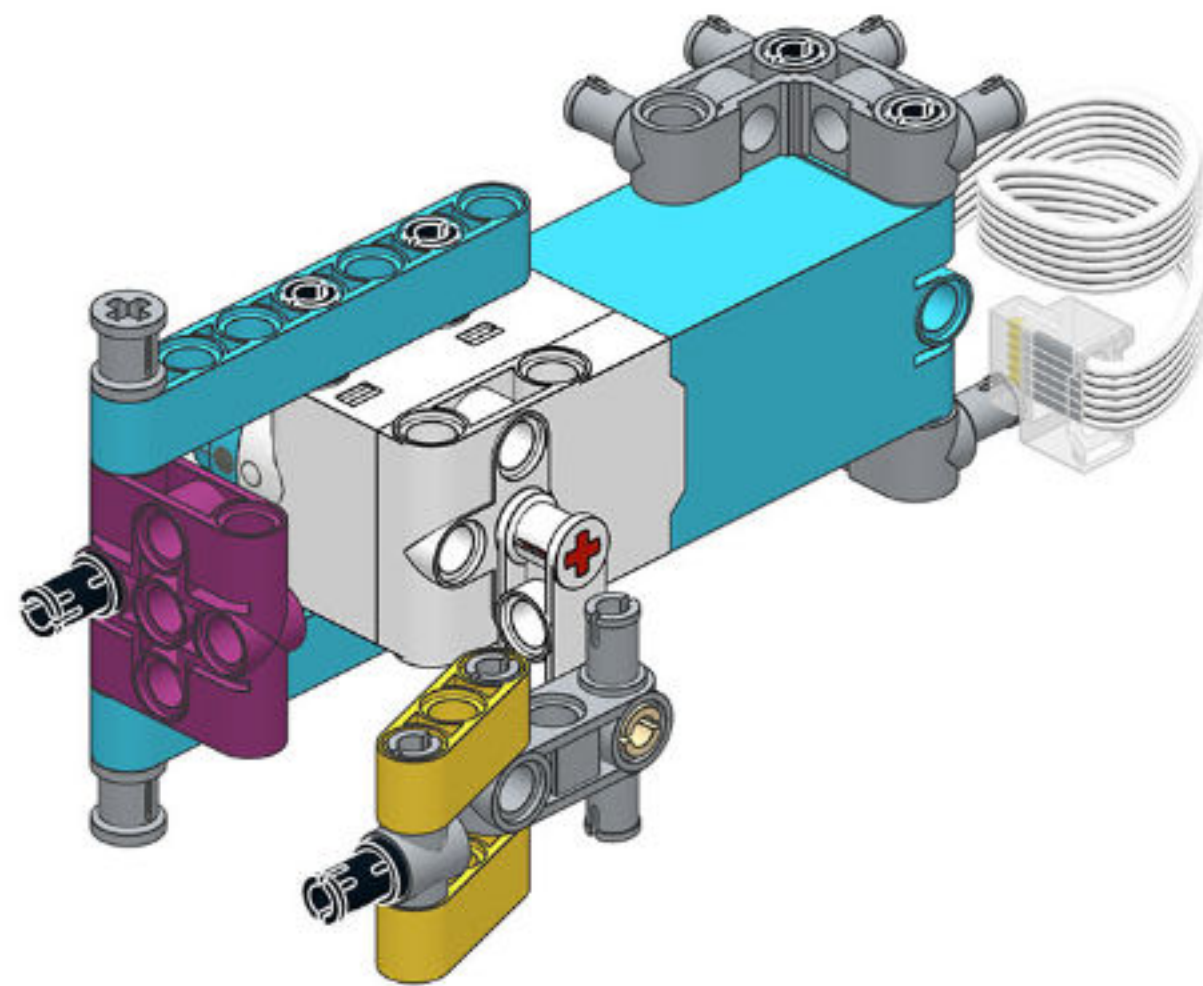

pawelbaskowski@gmail.com



26

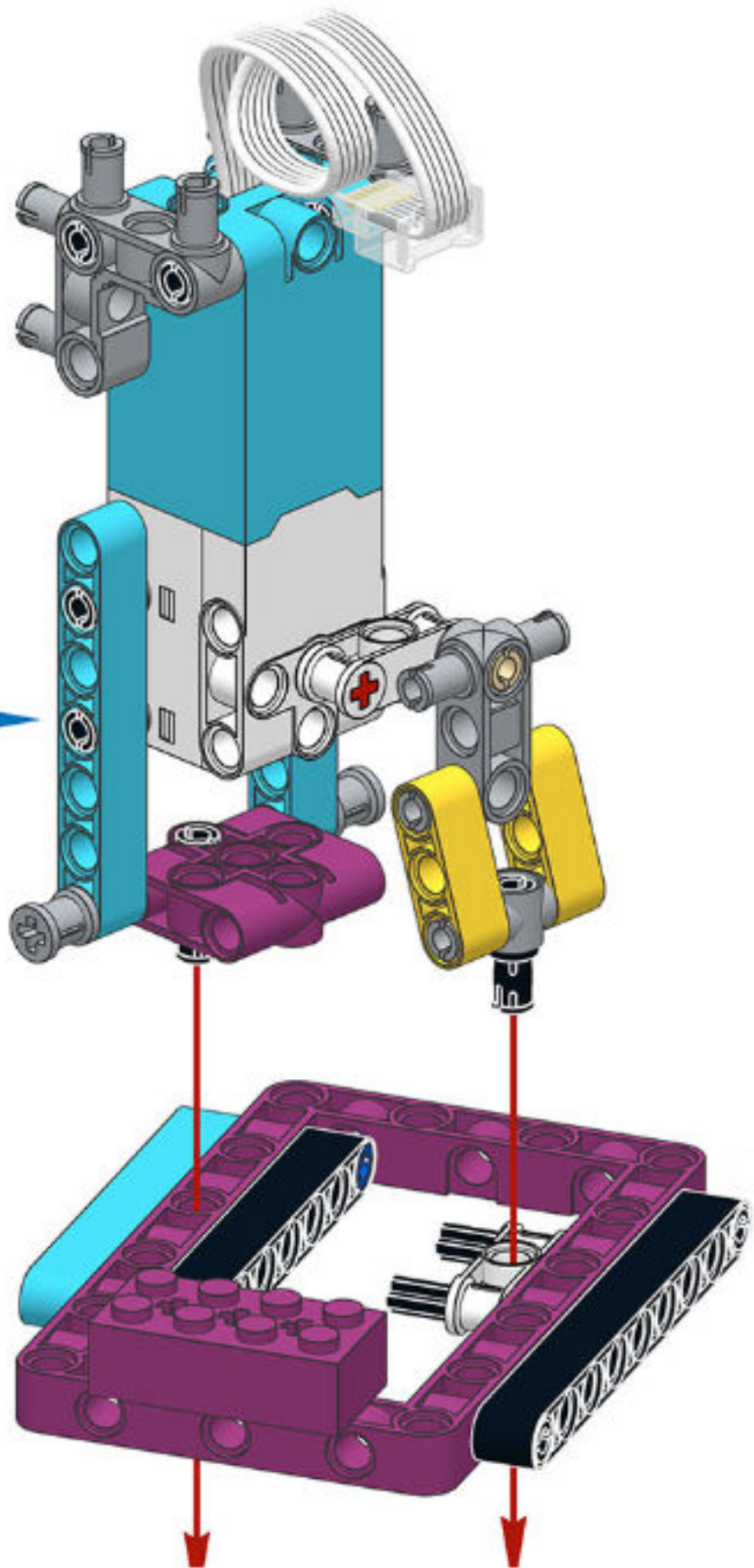

nowelbaskakow@gmail.com



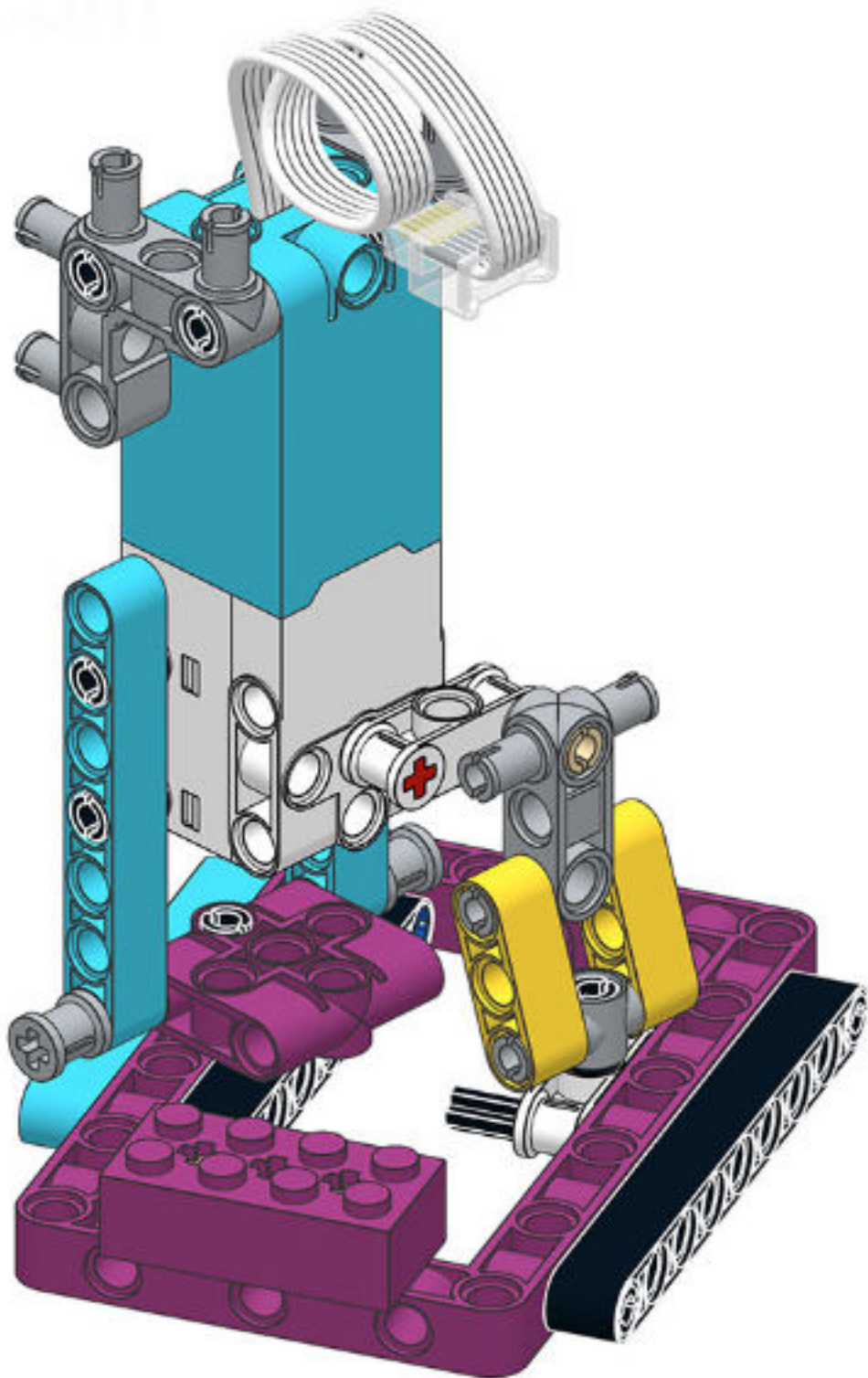

28/69

0

50

A collection of four hexagonal icons. The top one contains the text '28/69' and a small gear icon. The second one contains a yellow star icon and the number '0'. The third one contains a red and yellow circle icon. The bottom one contains the number '50'.

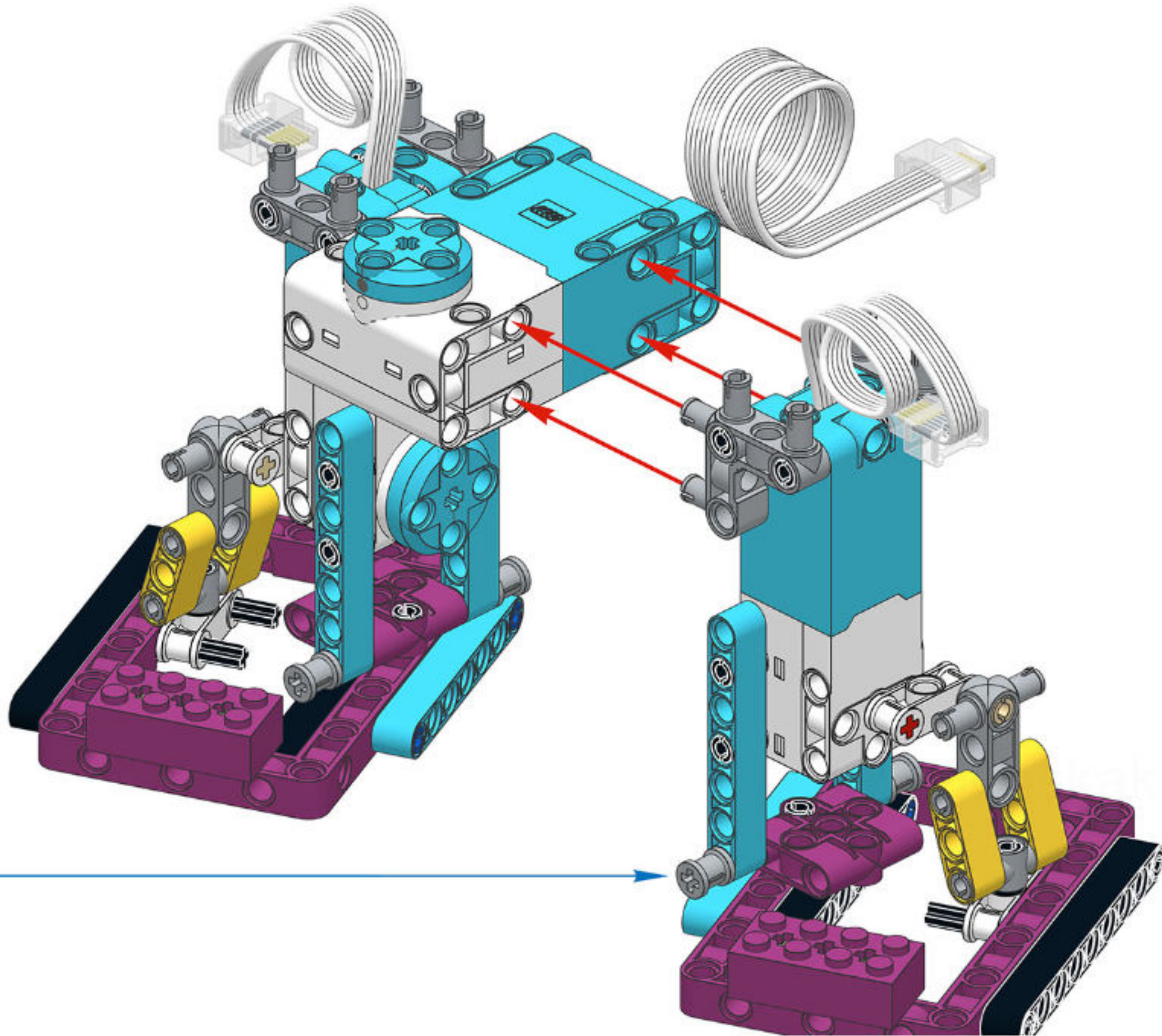

29

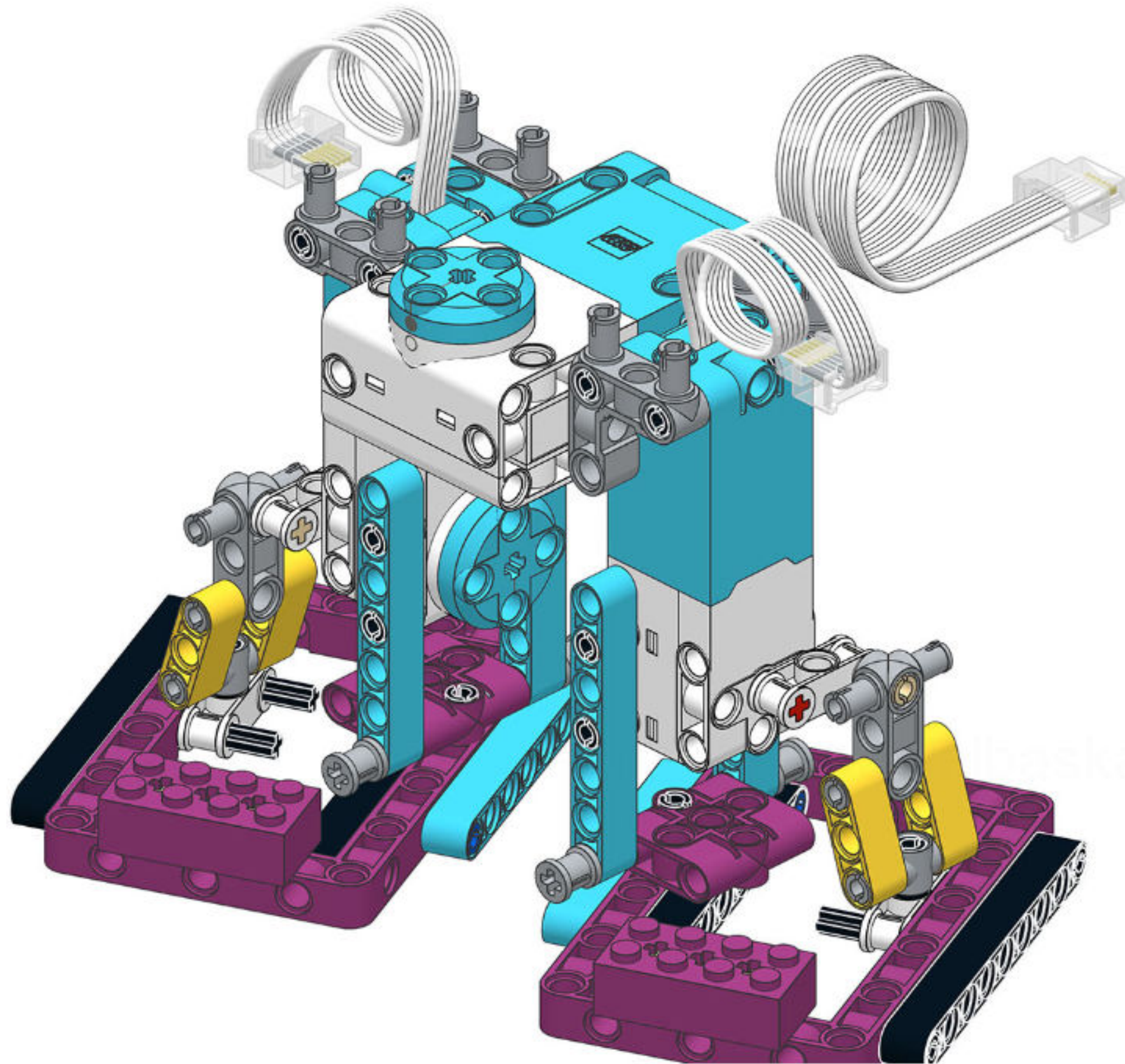

trskakov@gmail.com

30/69

0

52

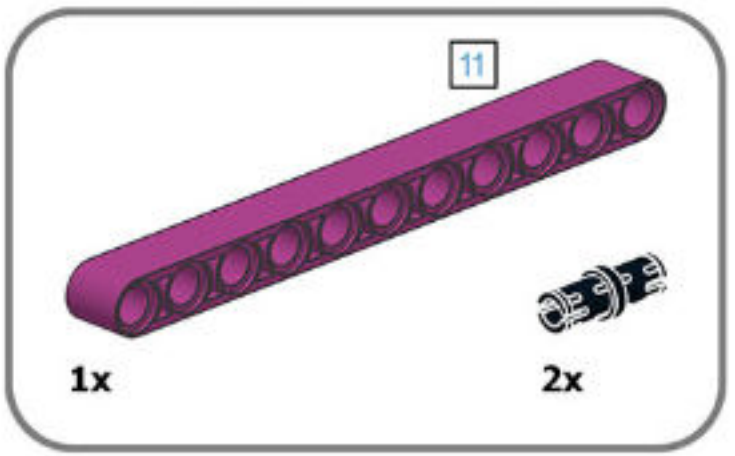

30

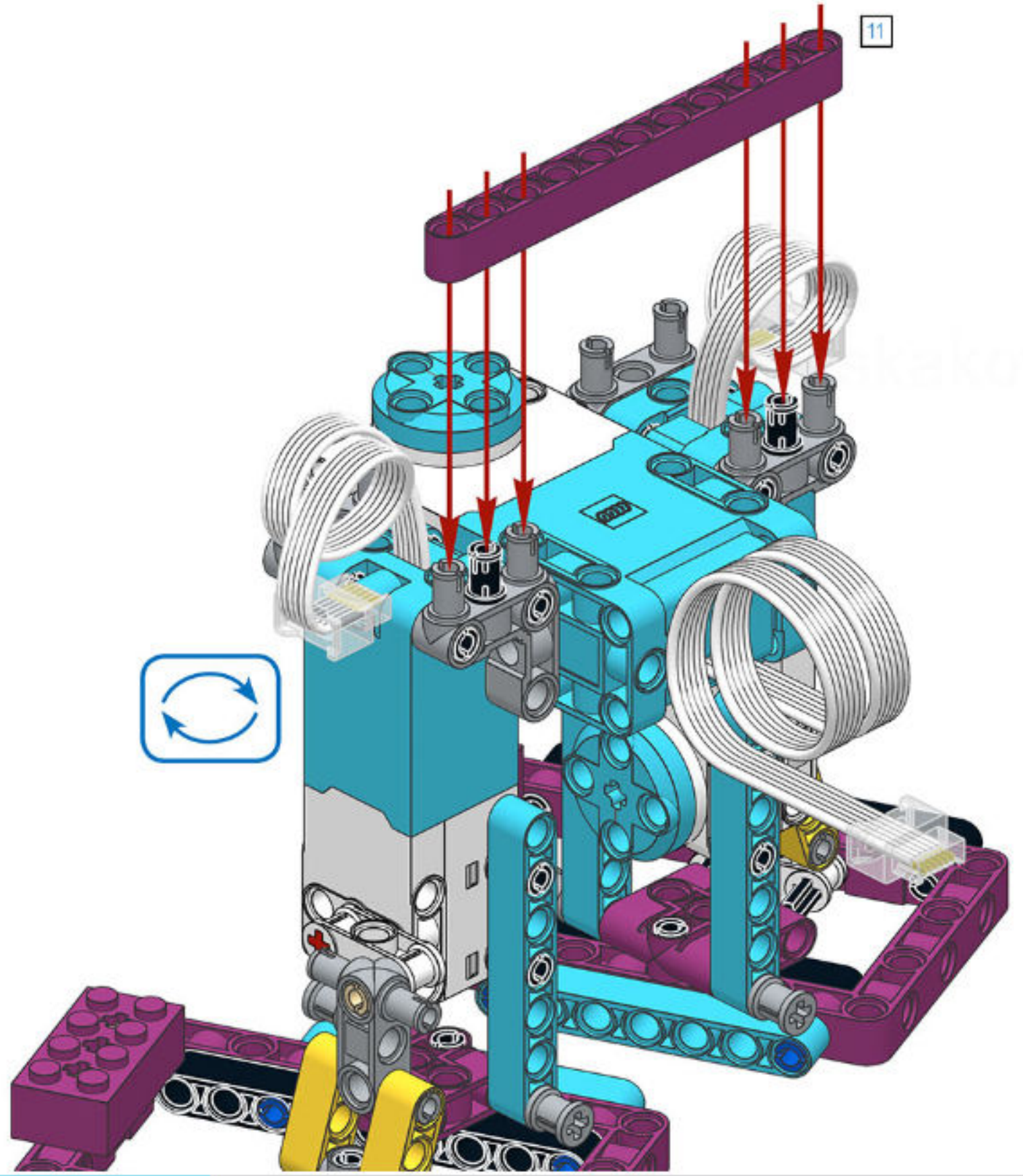

31/69

0

53

31

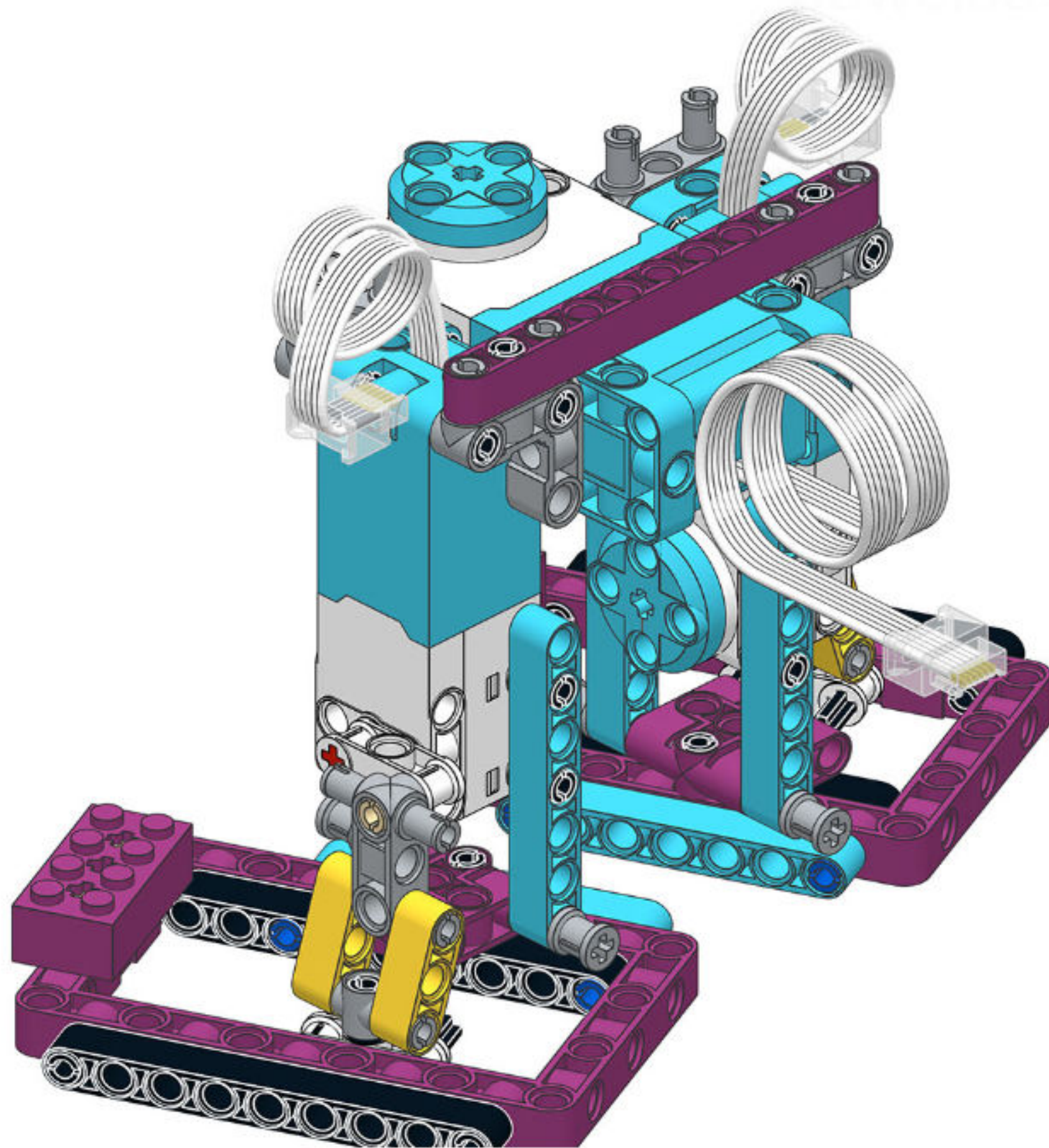

32/69

0

54

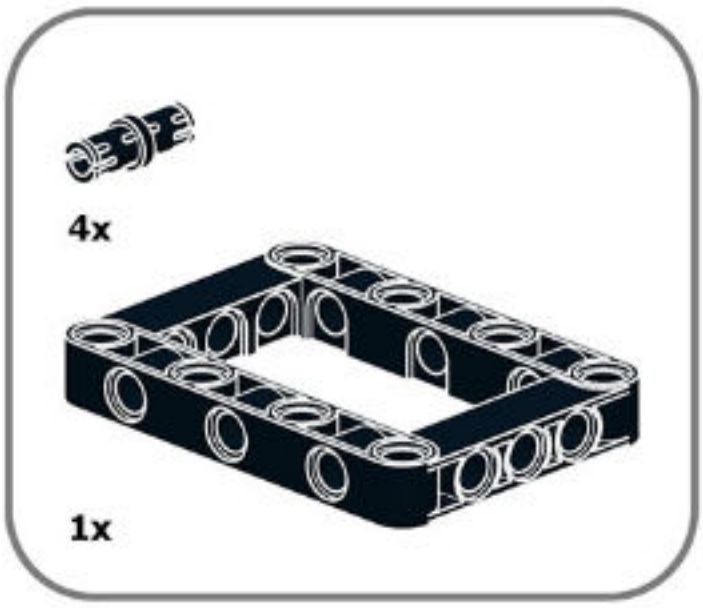

32

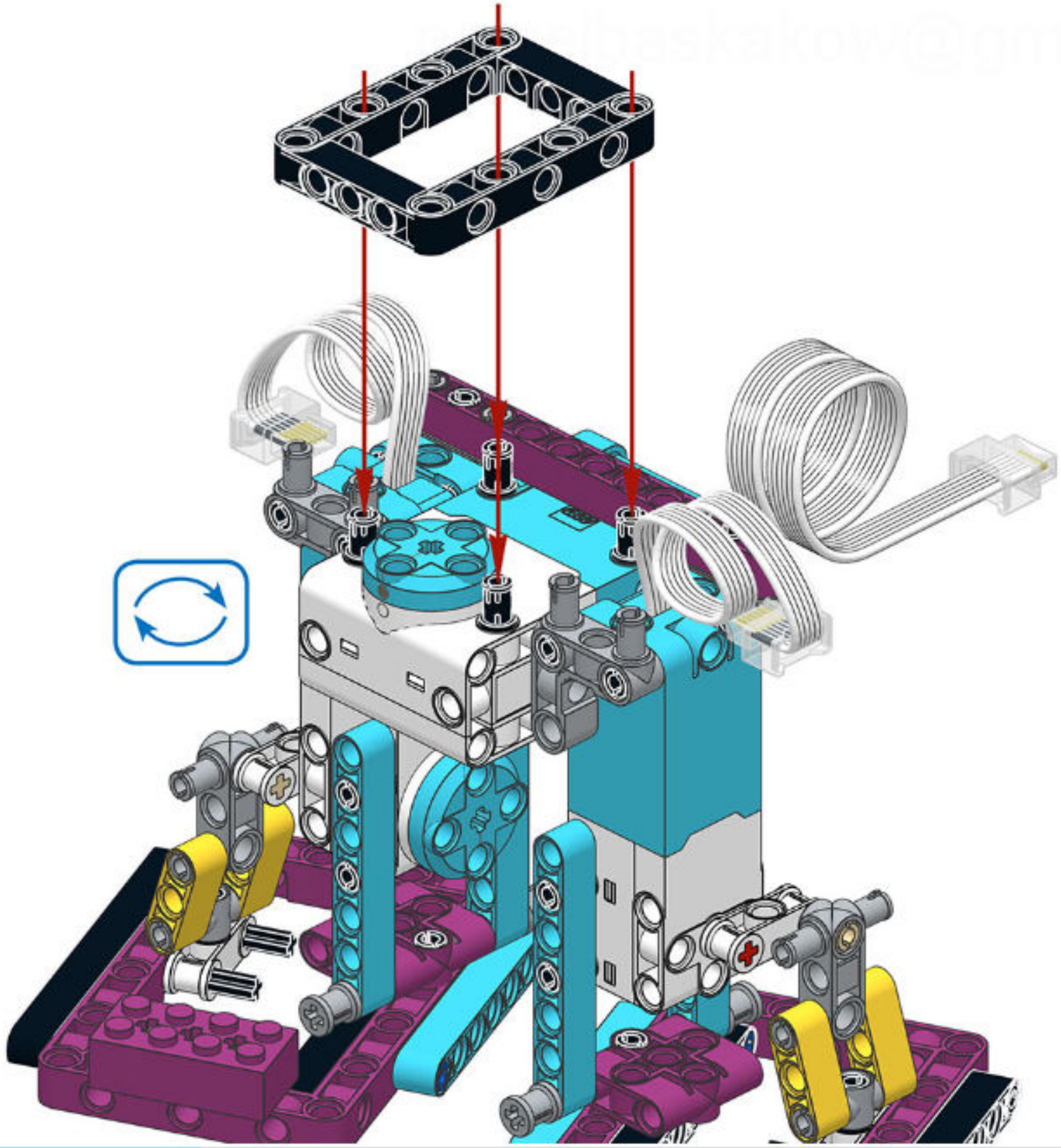

33/69

0

55



33

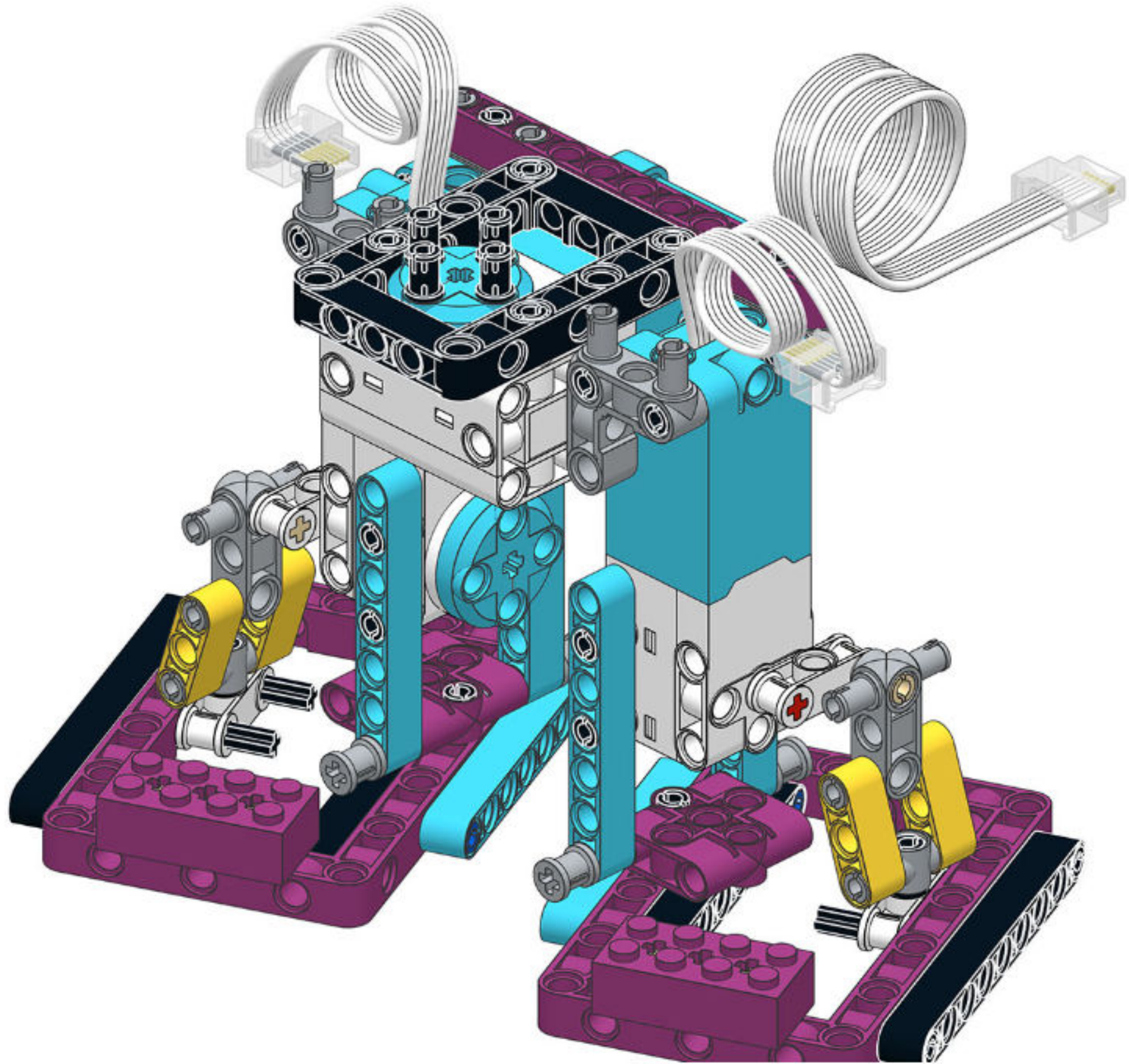

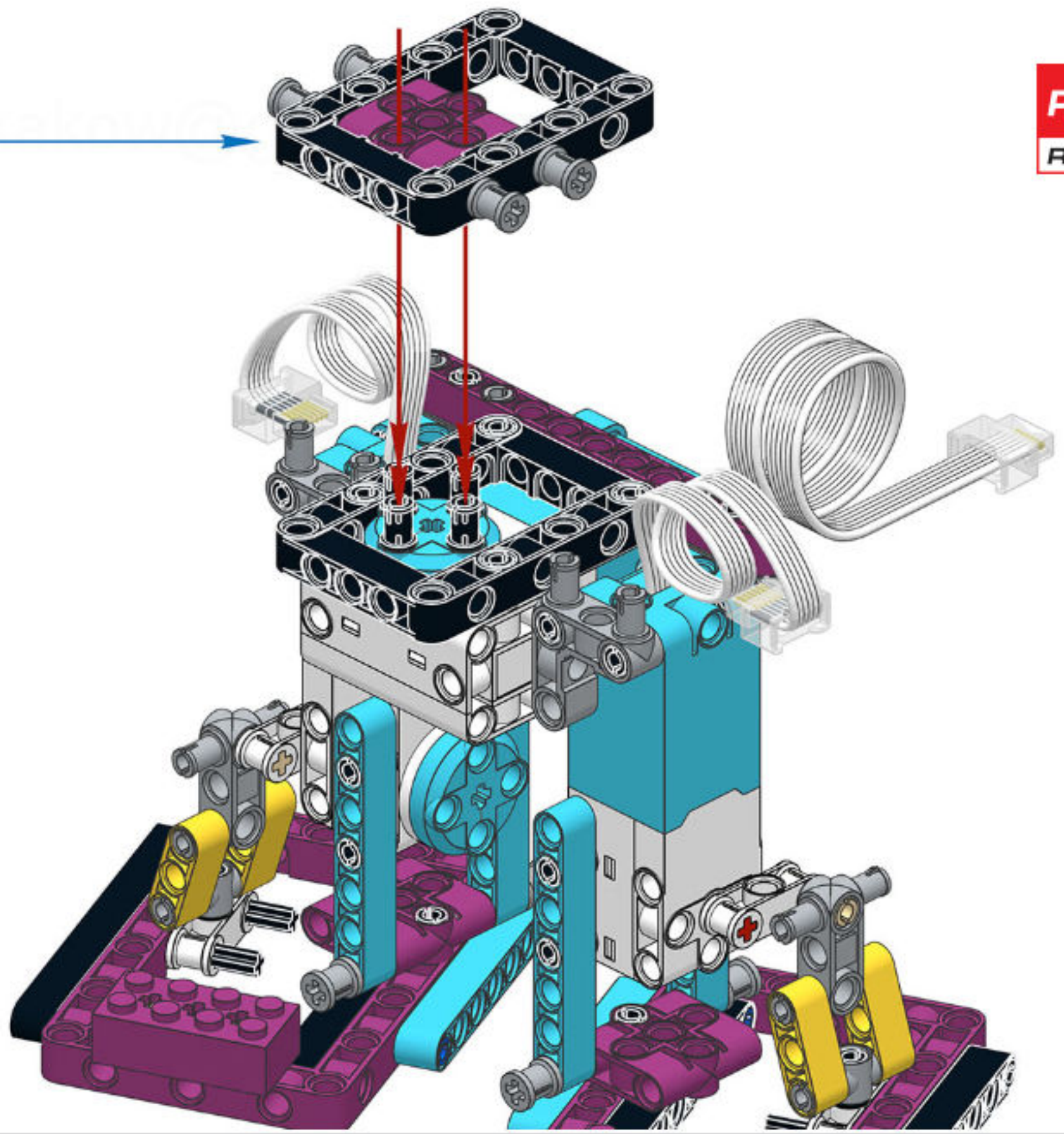
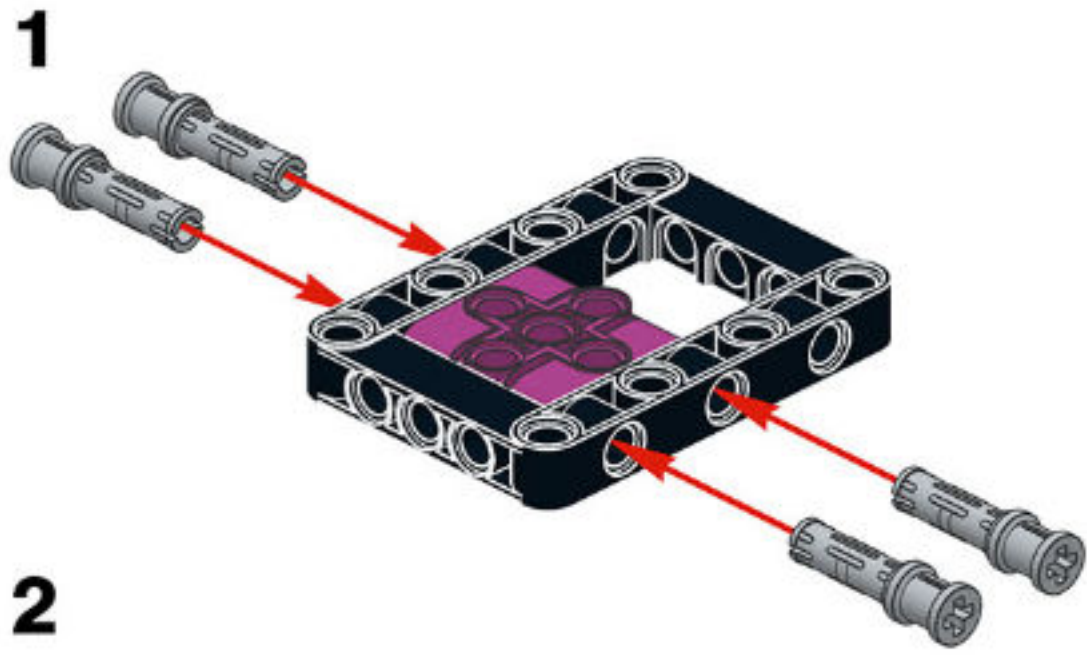
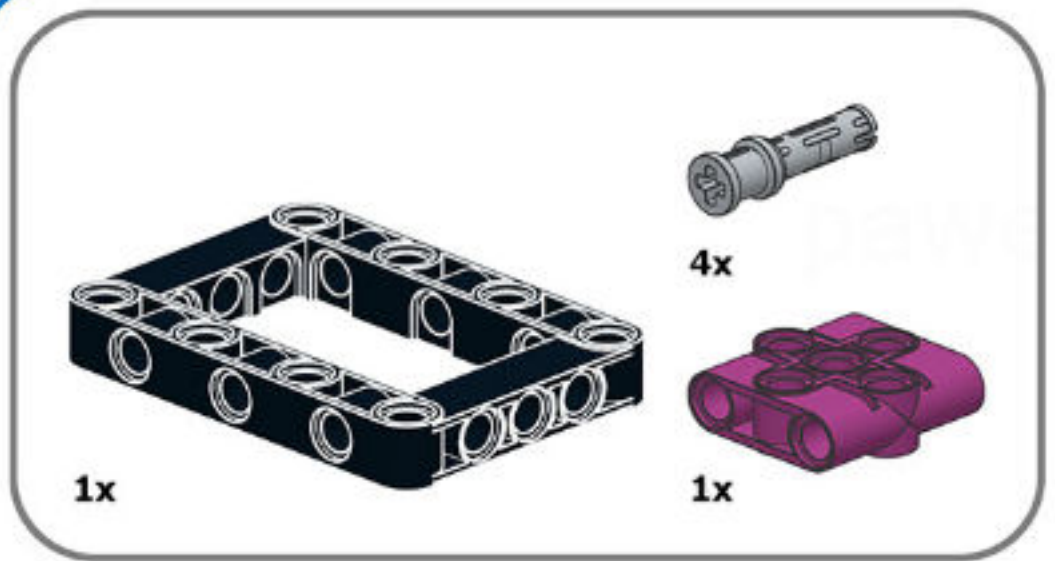

35/69

0

57

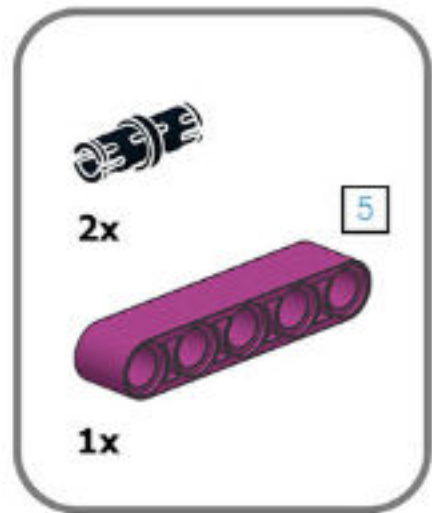

35

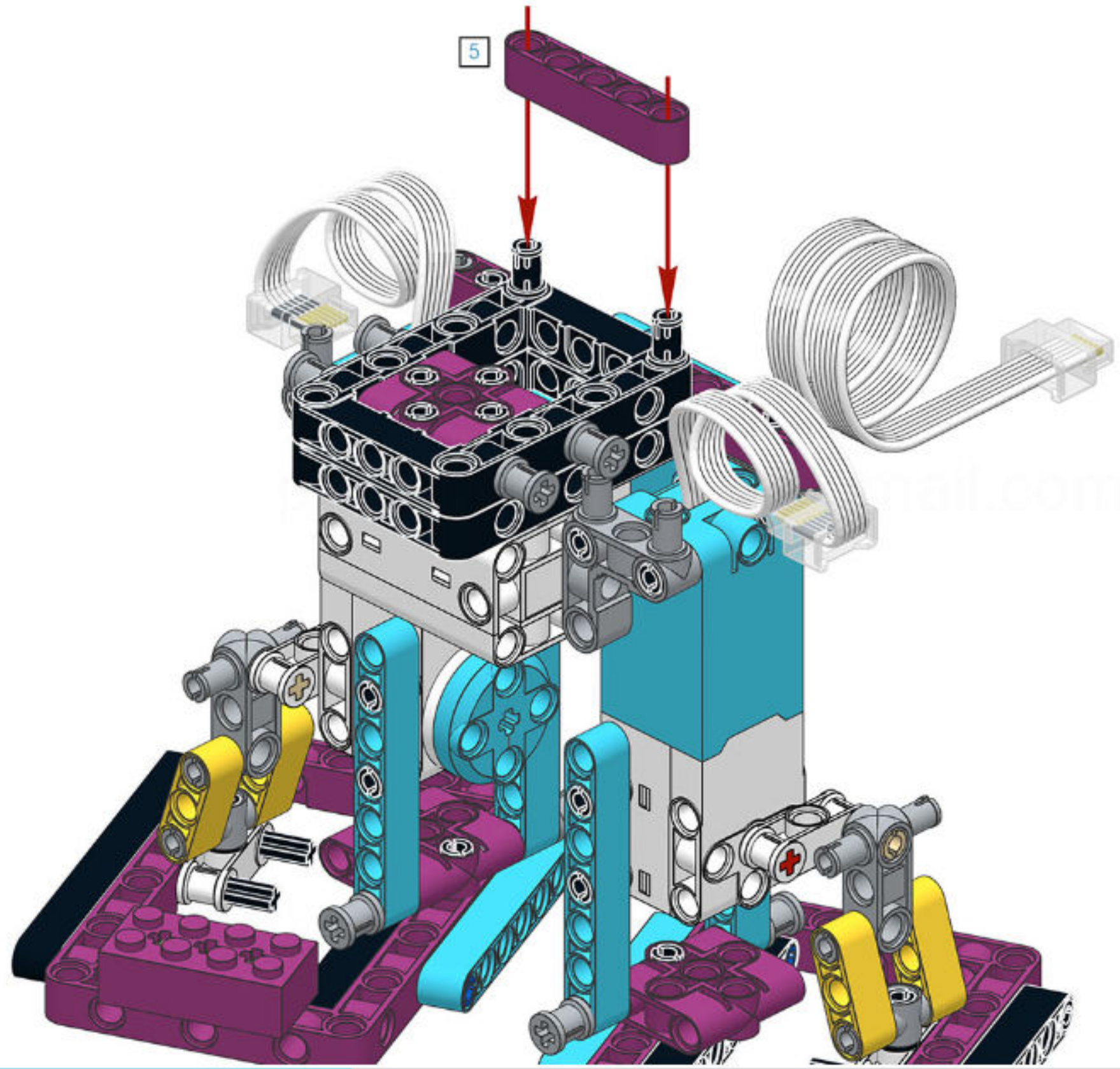

36/69

0

58

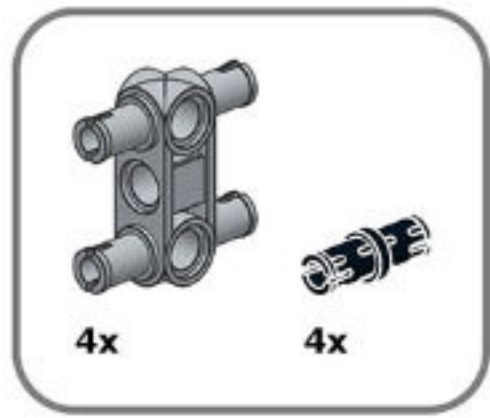

36

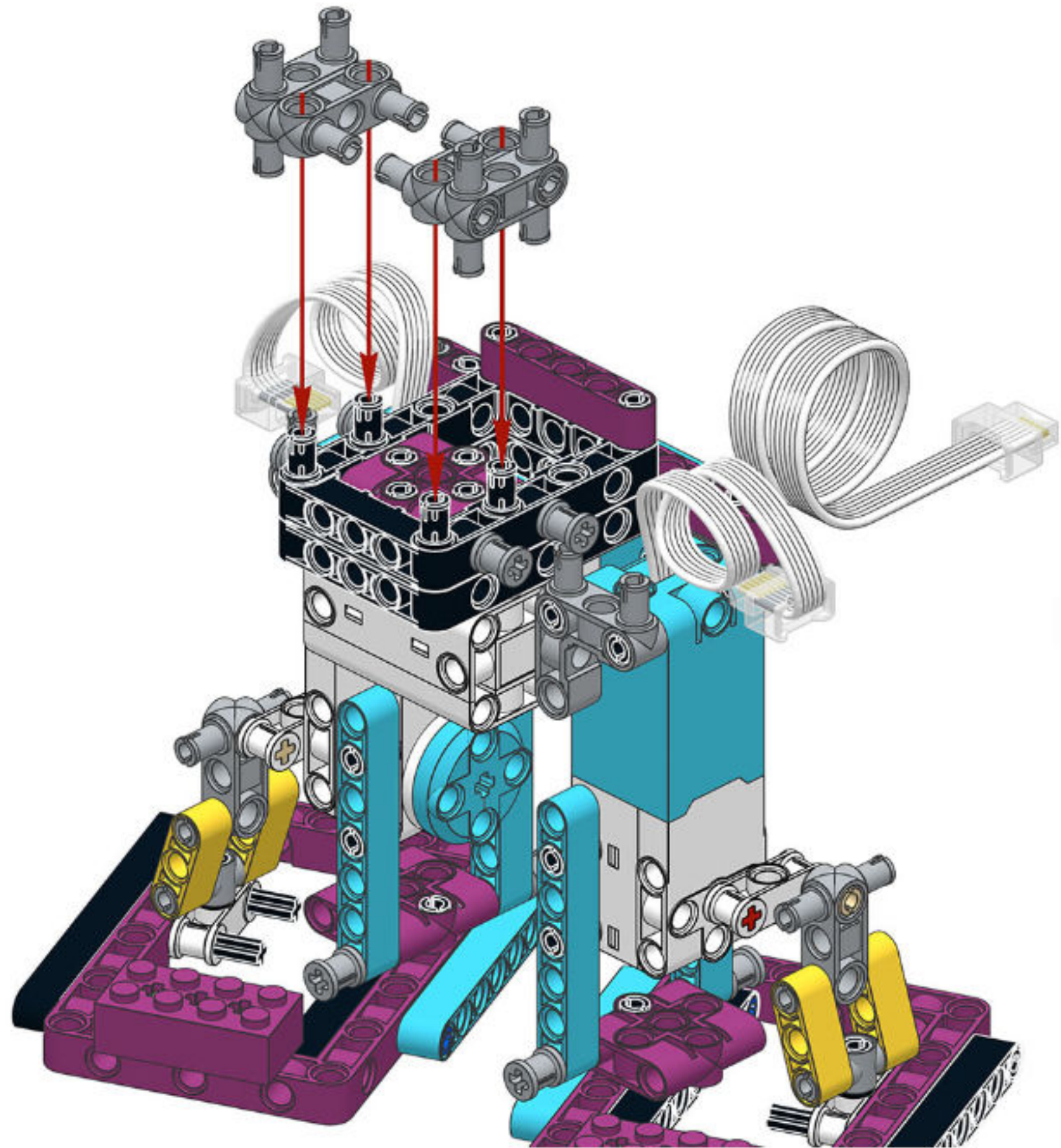

pevelbeskako

37/69

0

59

37

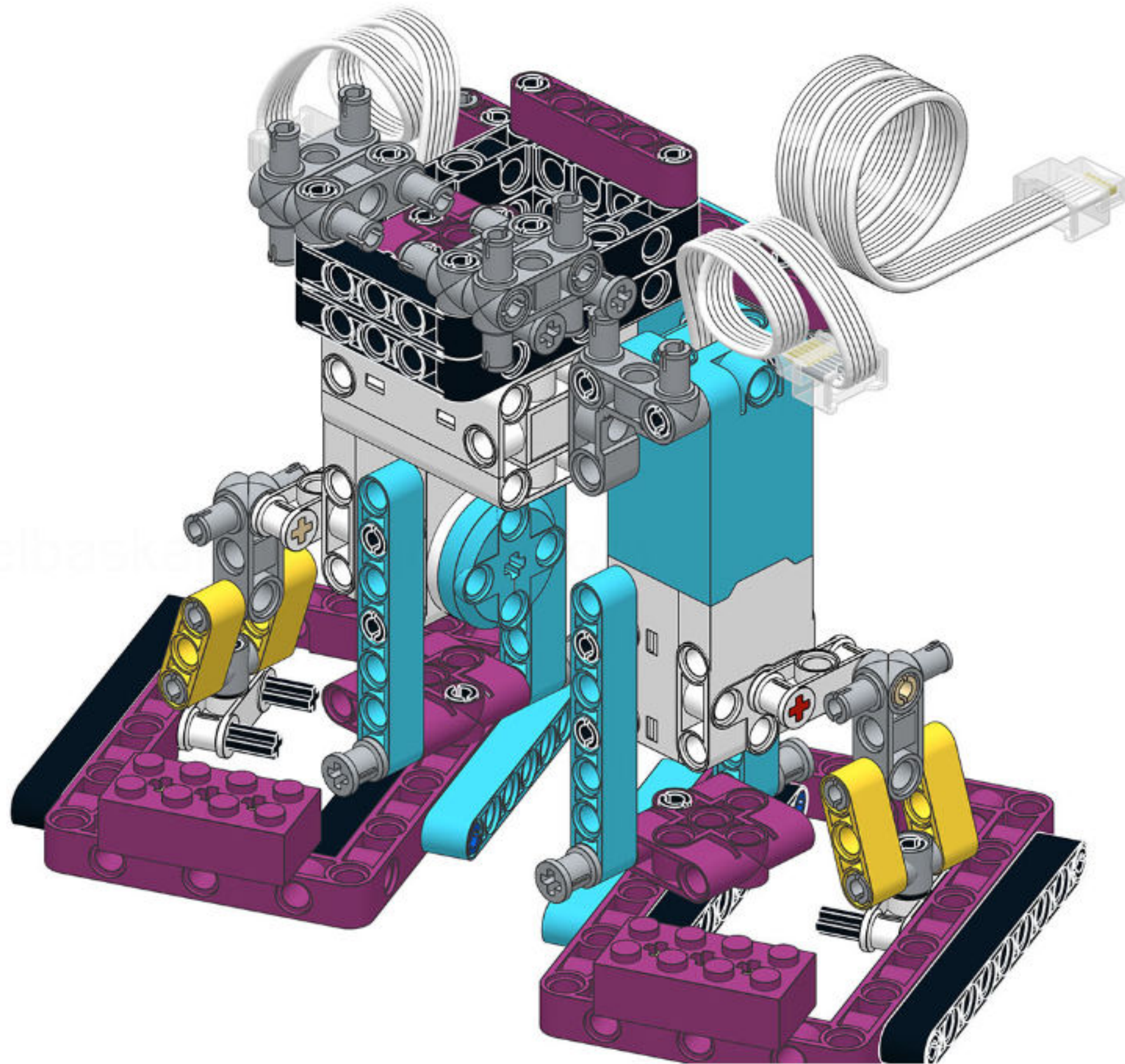

pawelbaski

38/69

0

60



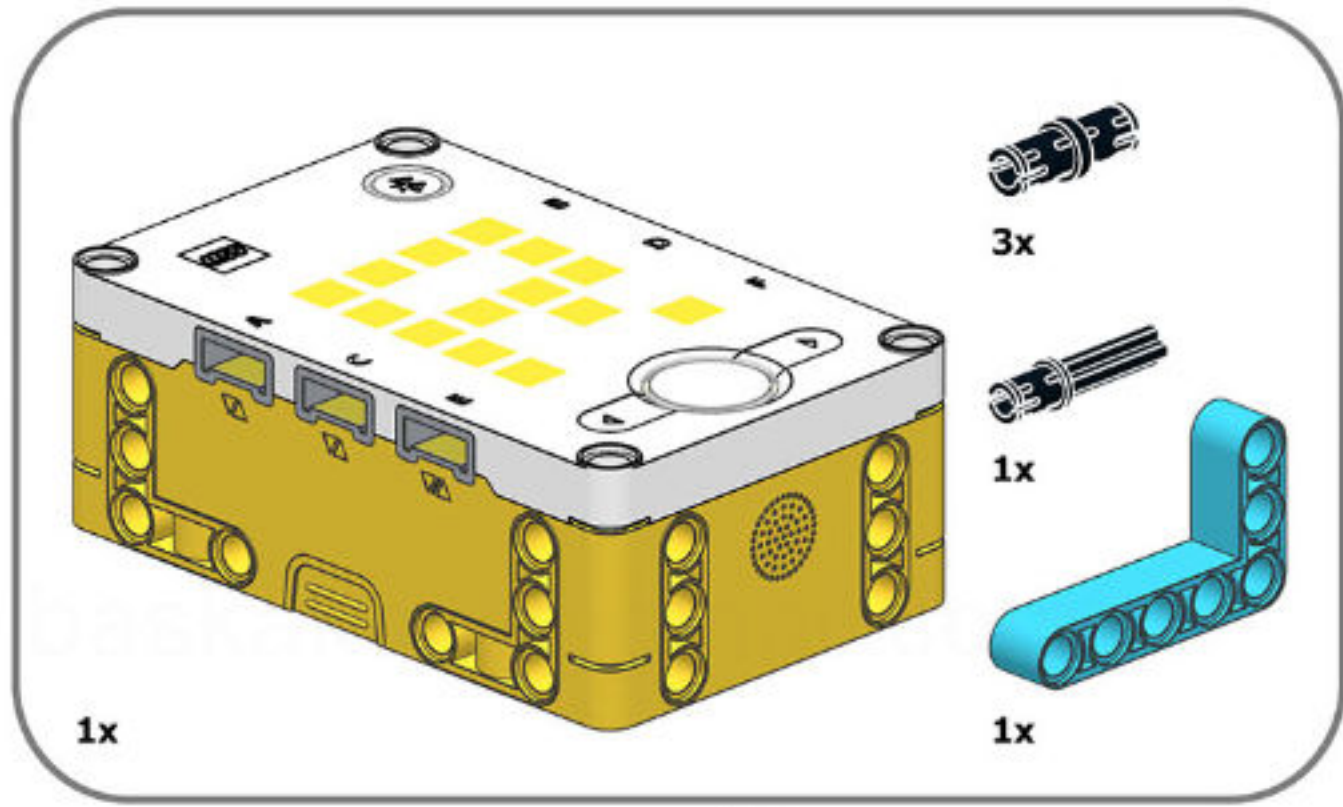
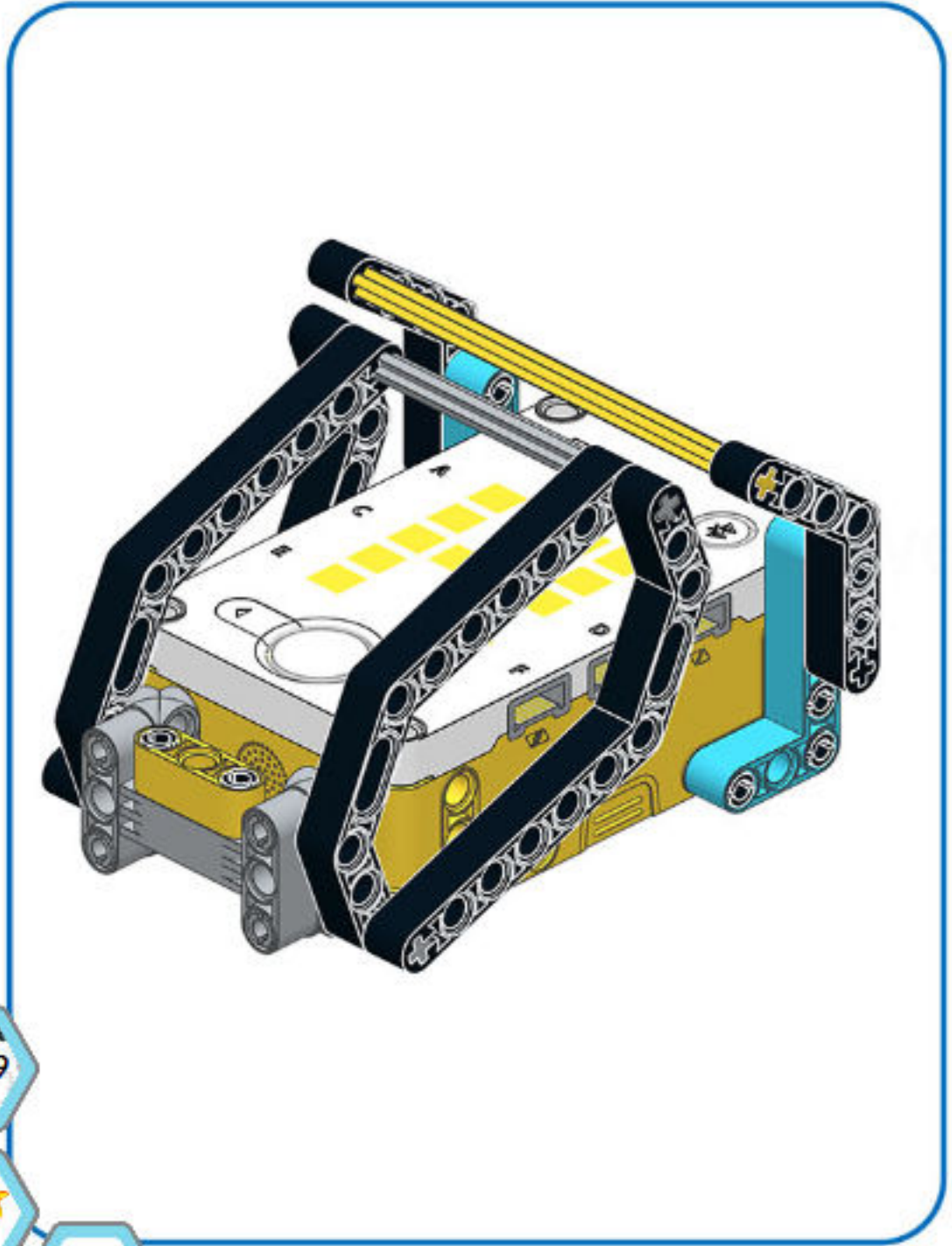

38

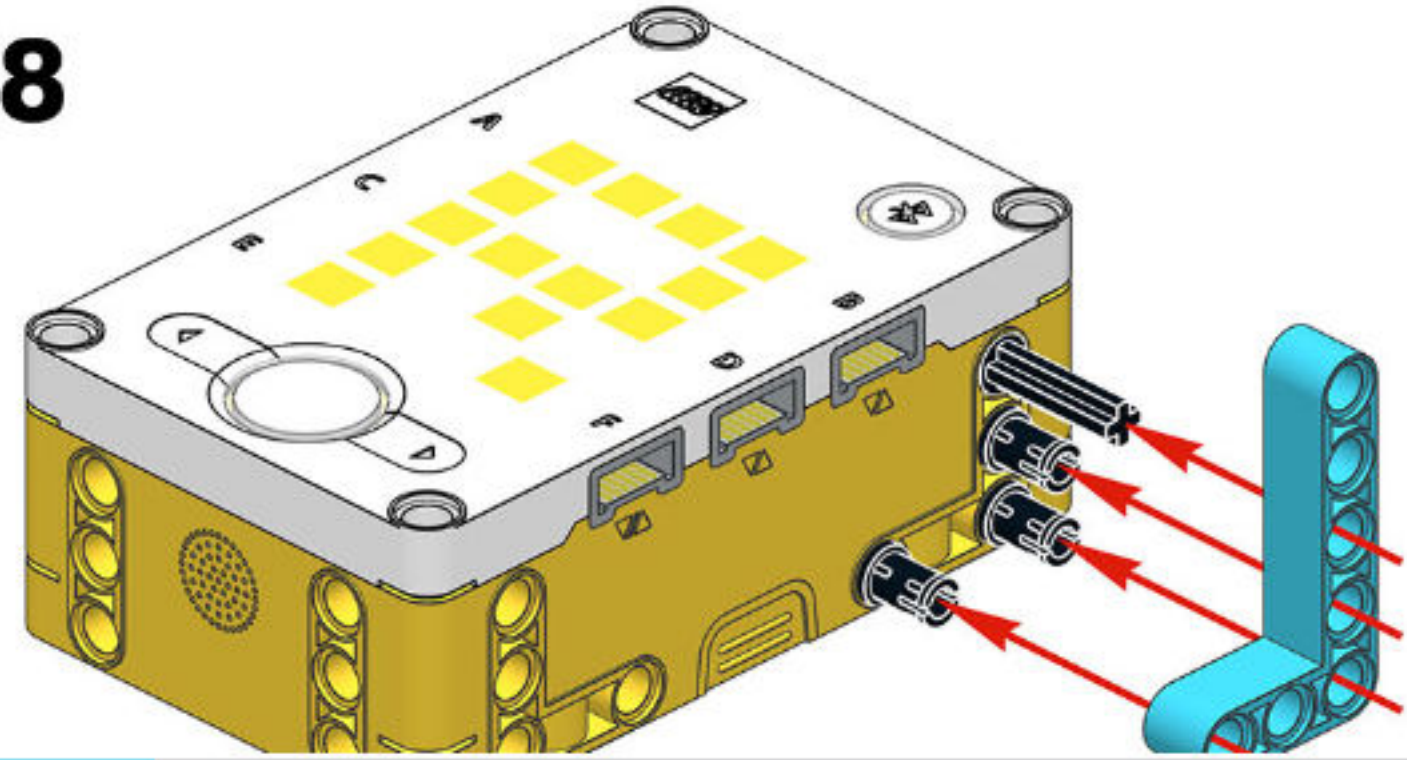

39/69

0

61

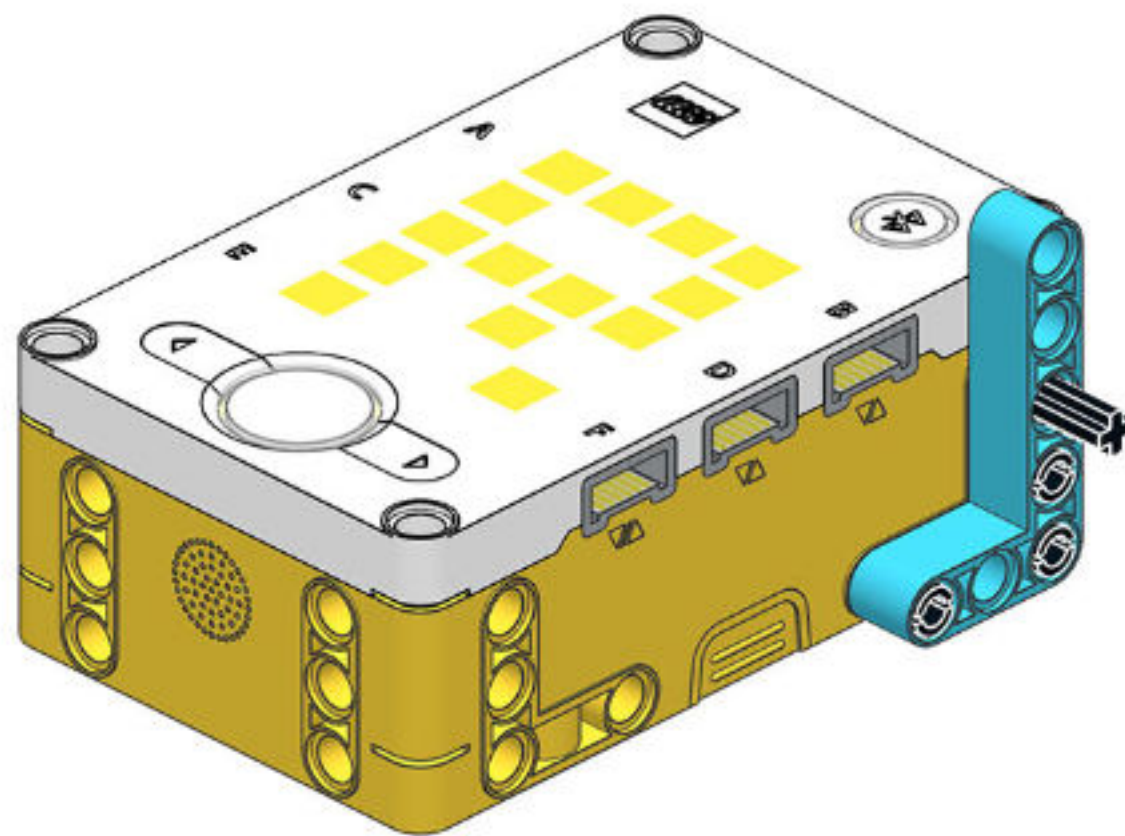

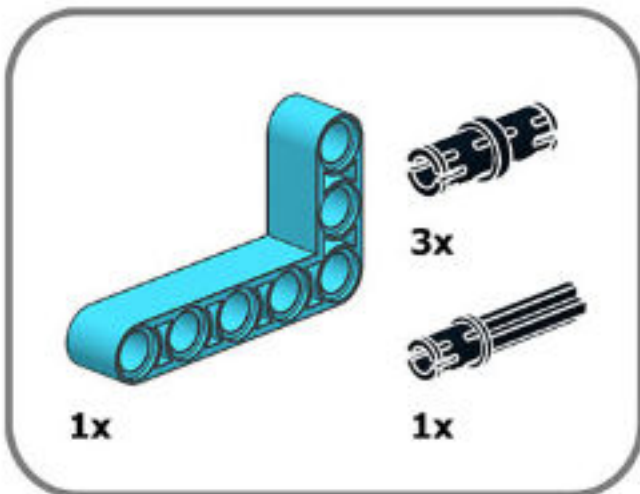

40

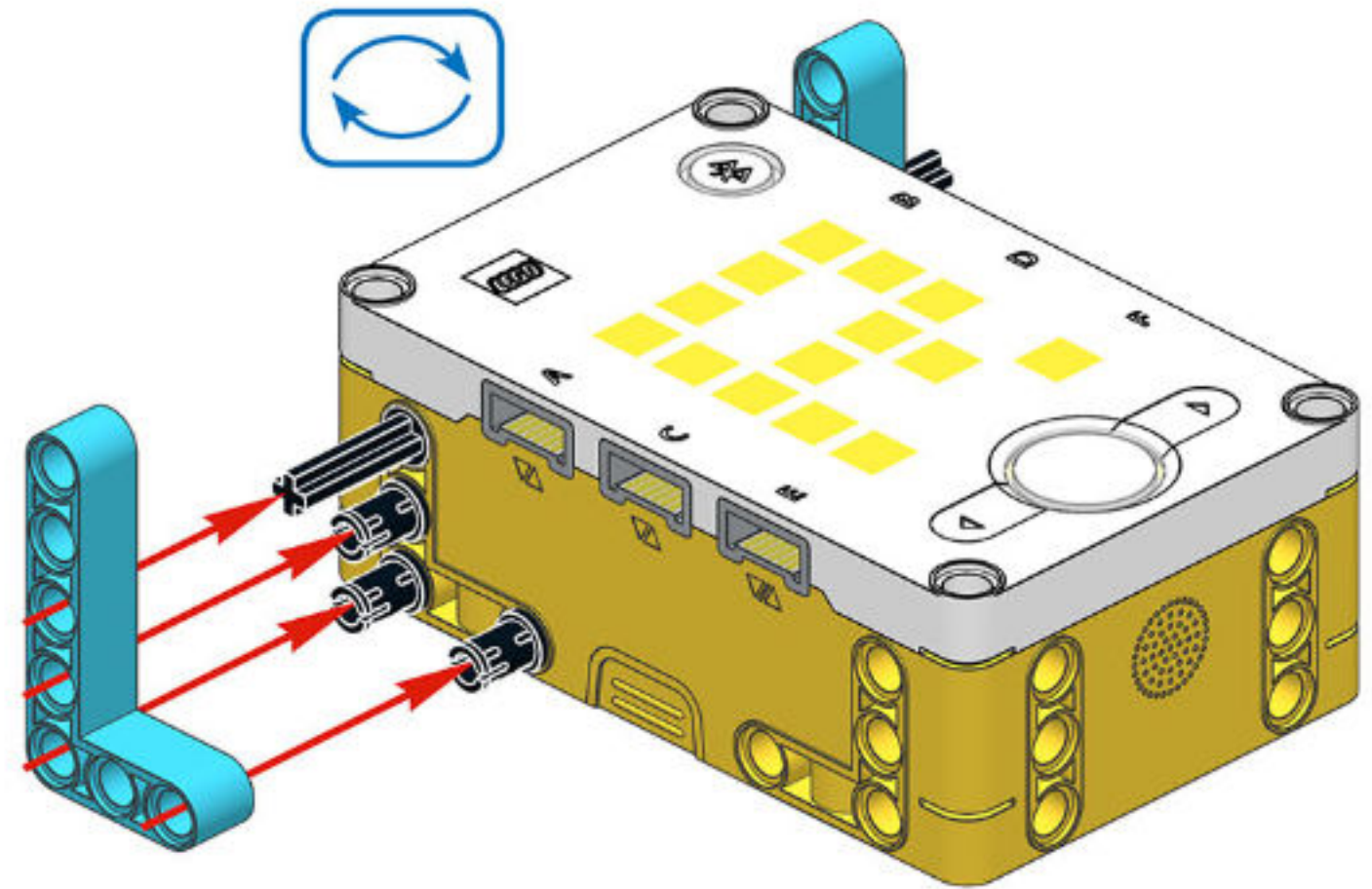

41/69
0
63



41

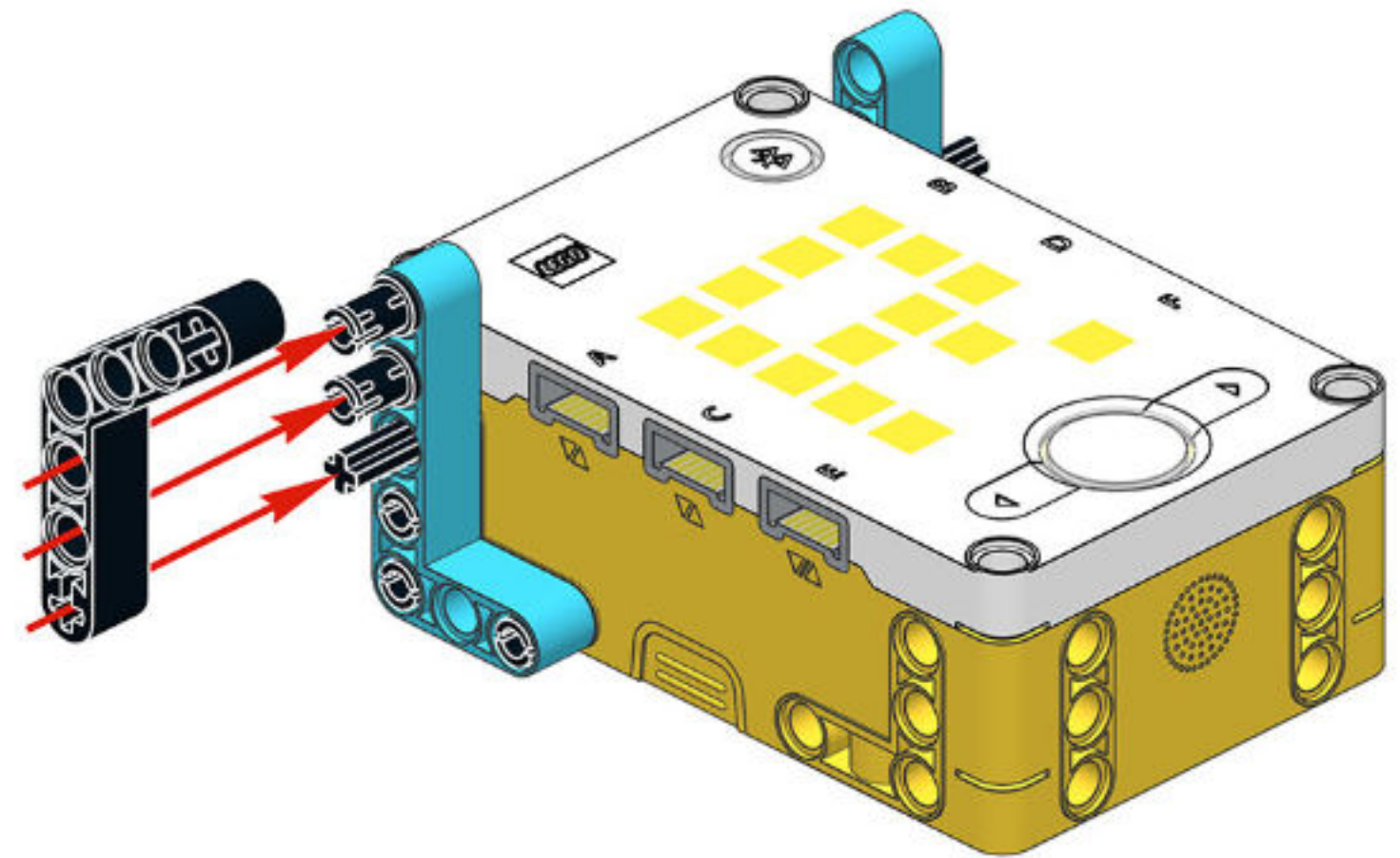

42/69

0

64

pavelbaskakov@gmail.com

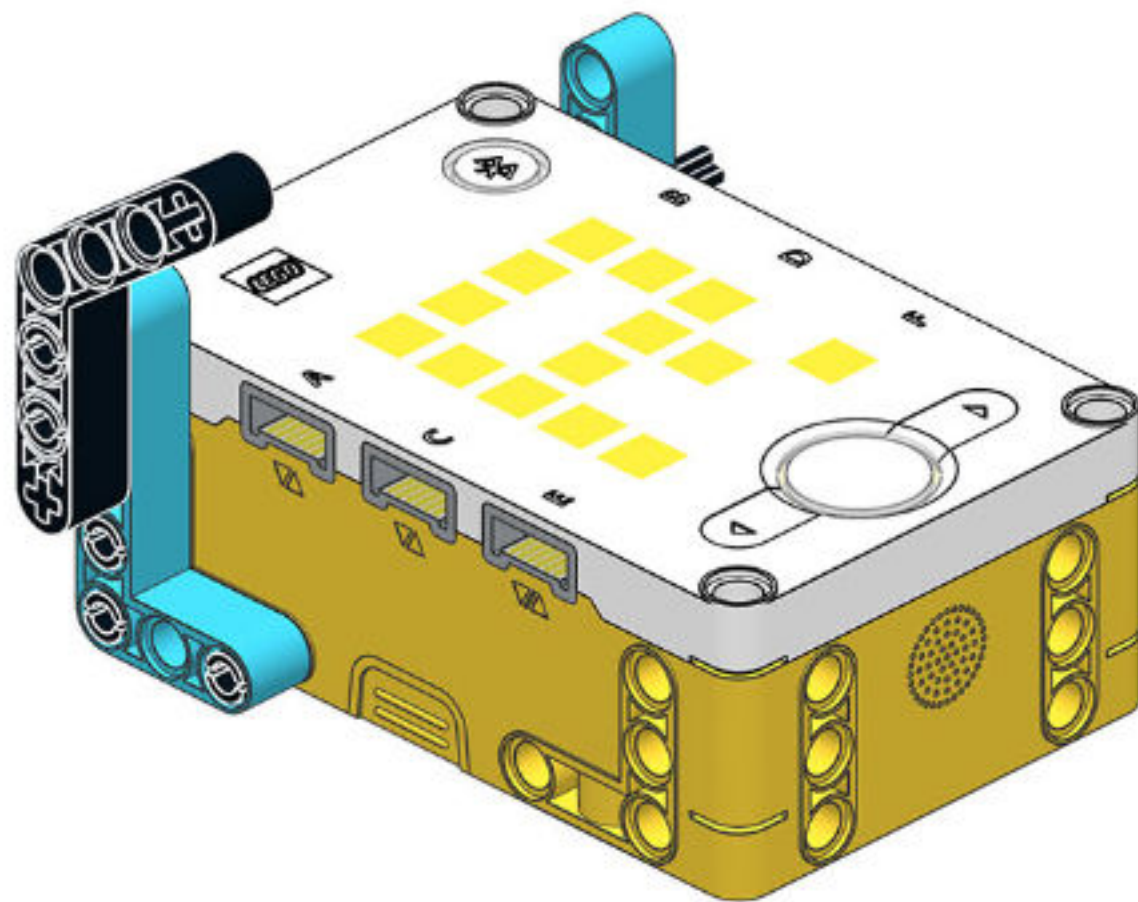

43/69

0

65

A collection of three hexagonal icons. The top one is labeled '43/69' and contains a small gear icon. The middle one is labeled '0' and contains a yellow gear icon. The bottom one is labeled '65' and contains a red and yellow gear icon.

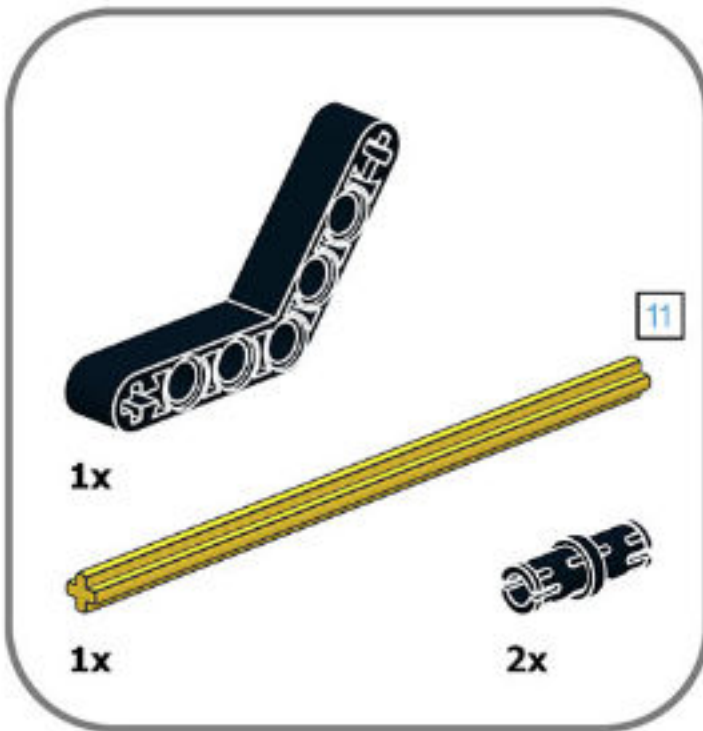

43

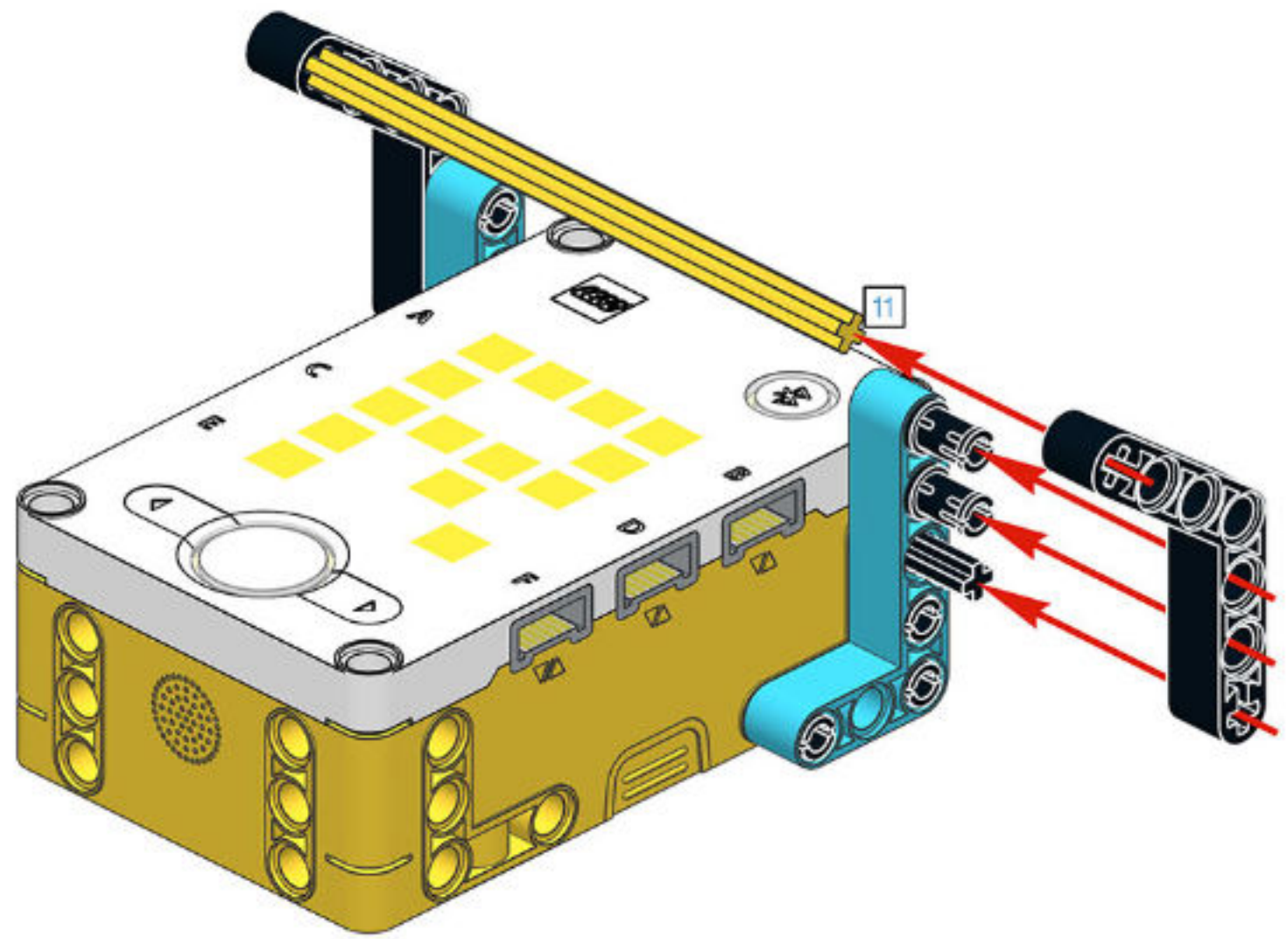

44/69

0

66

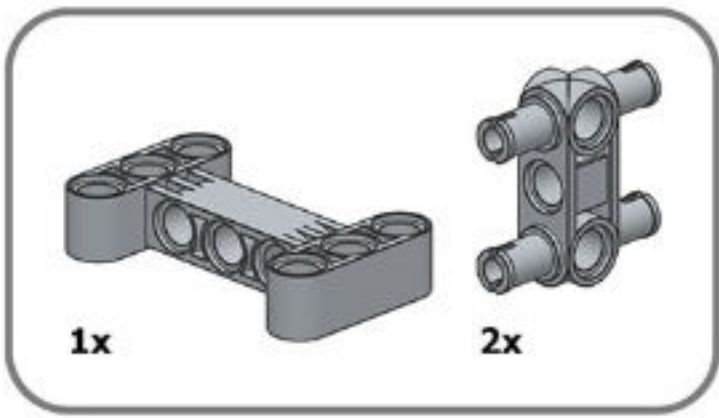

44

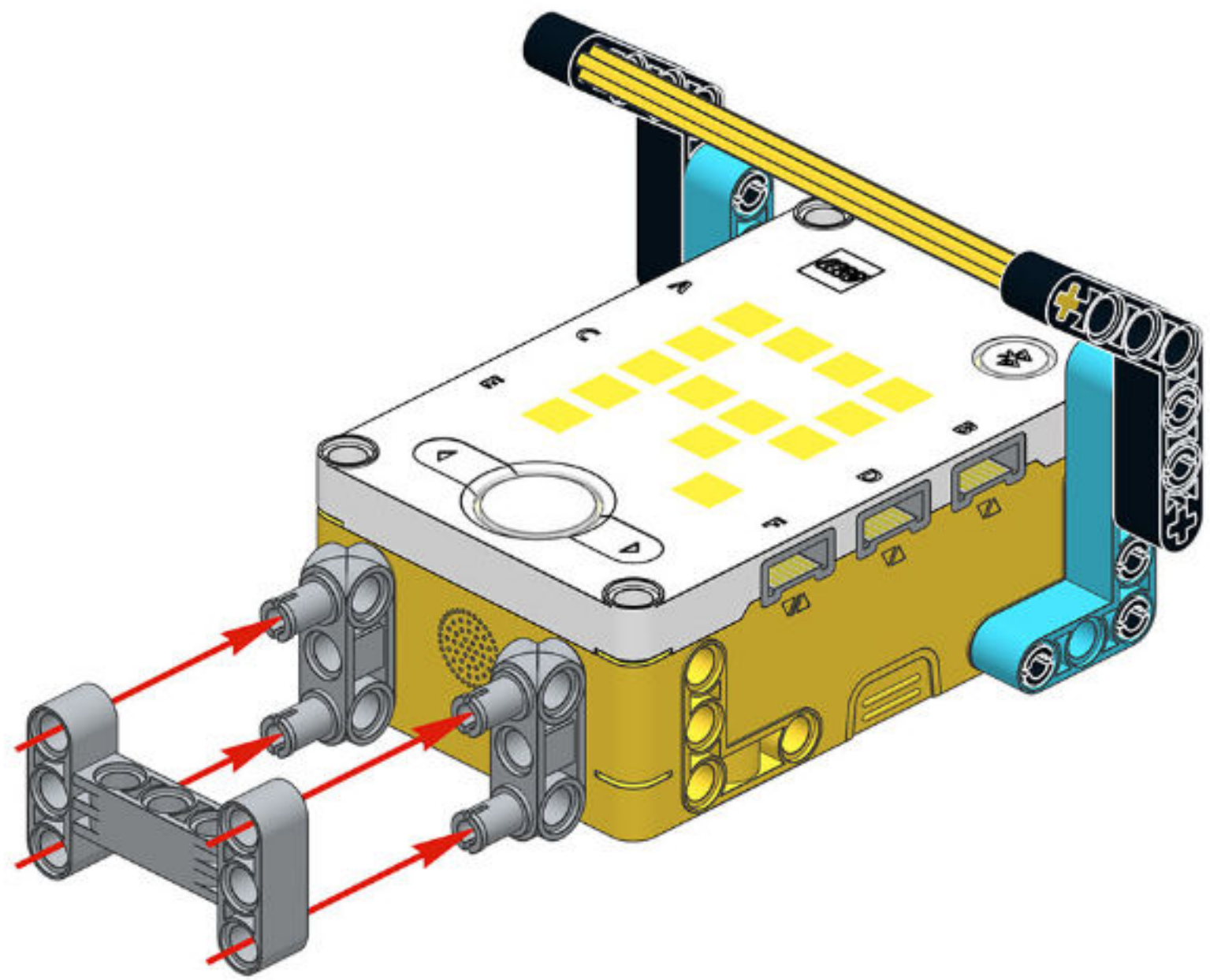

45/69

0

67

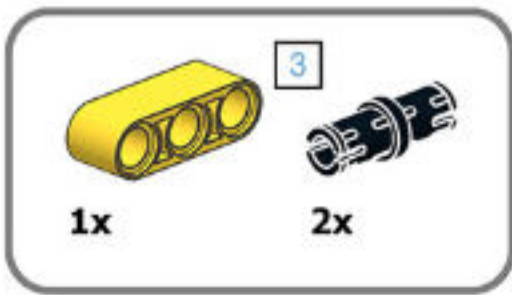

45

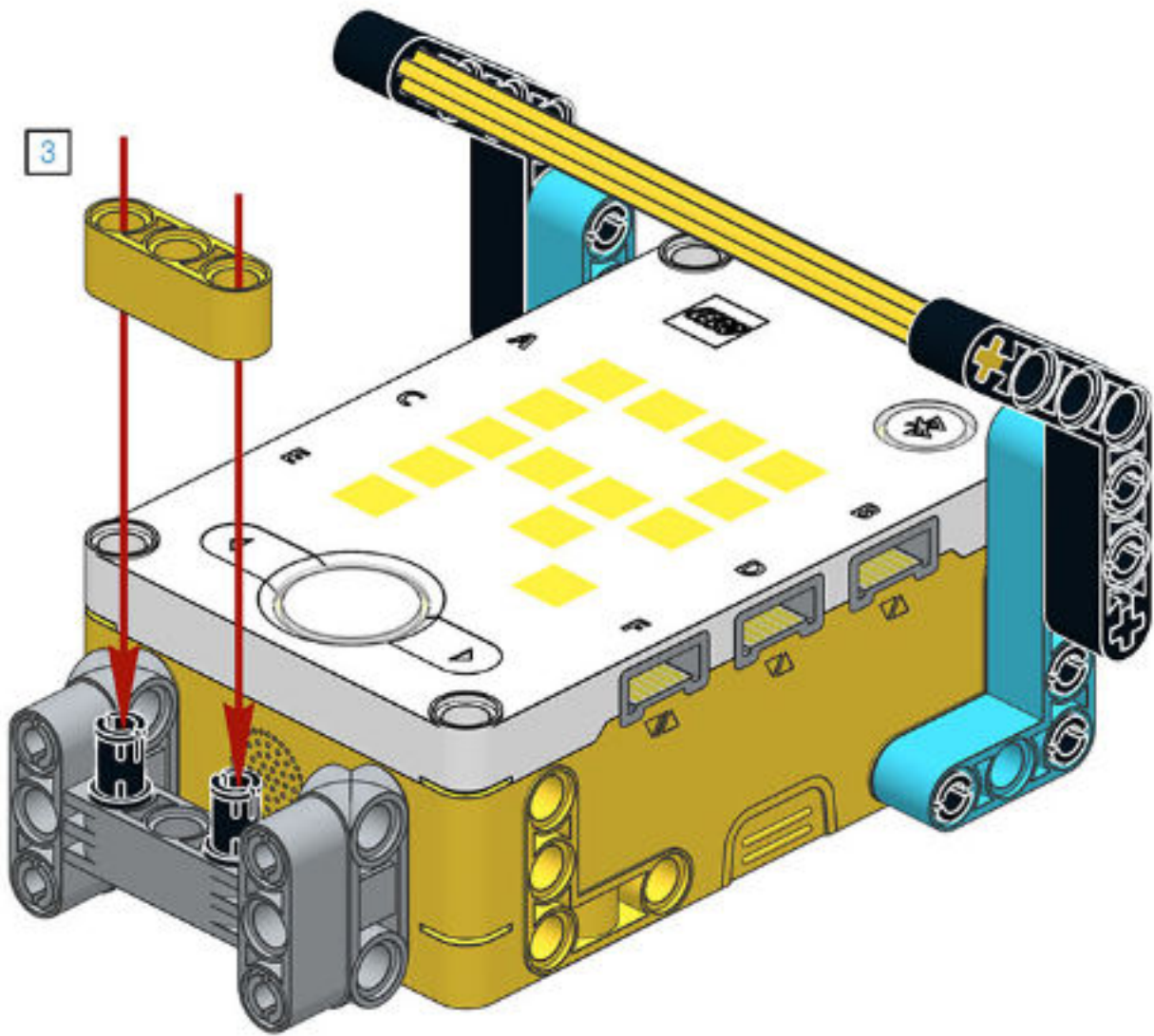

pawelbaskakow@

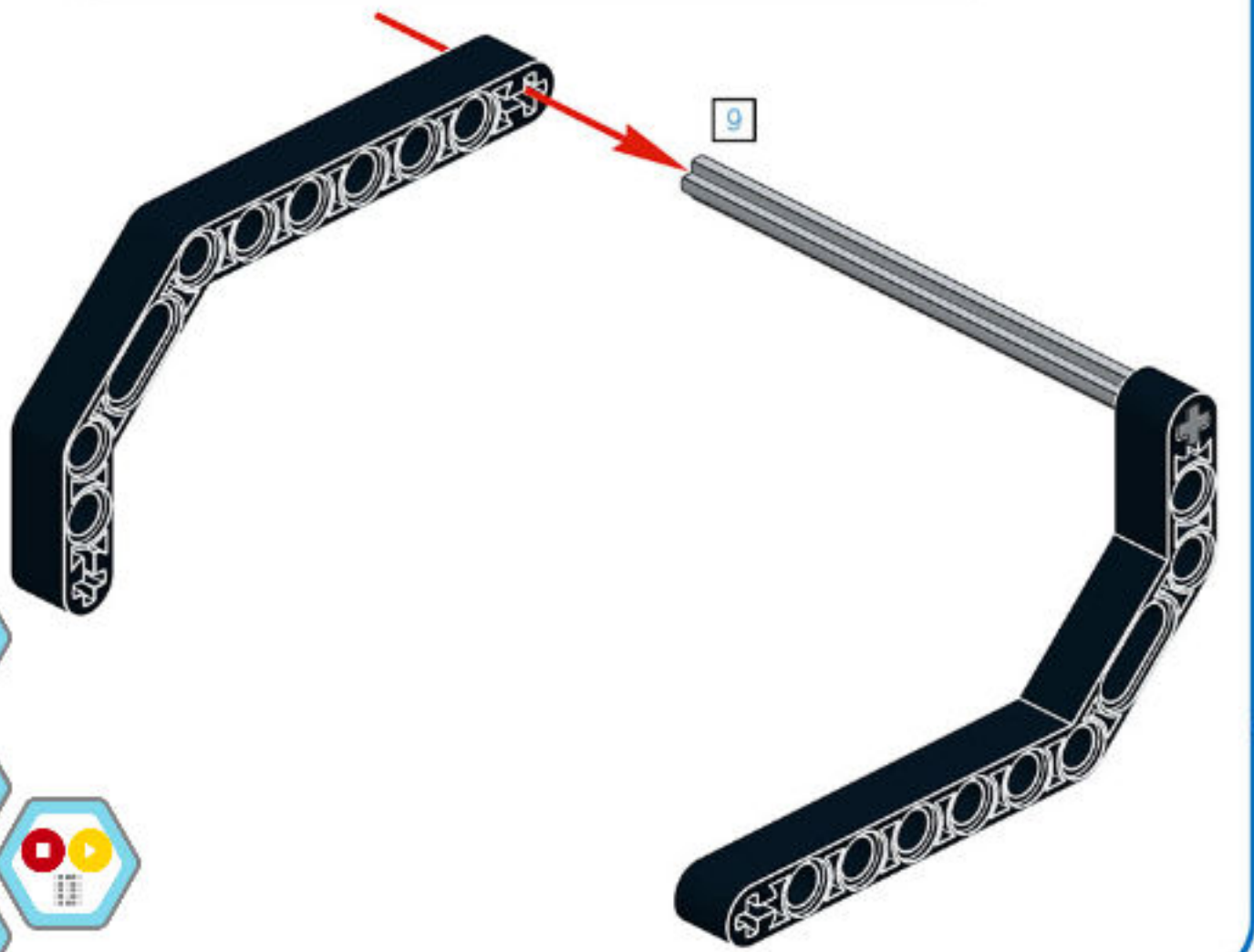
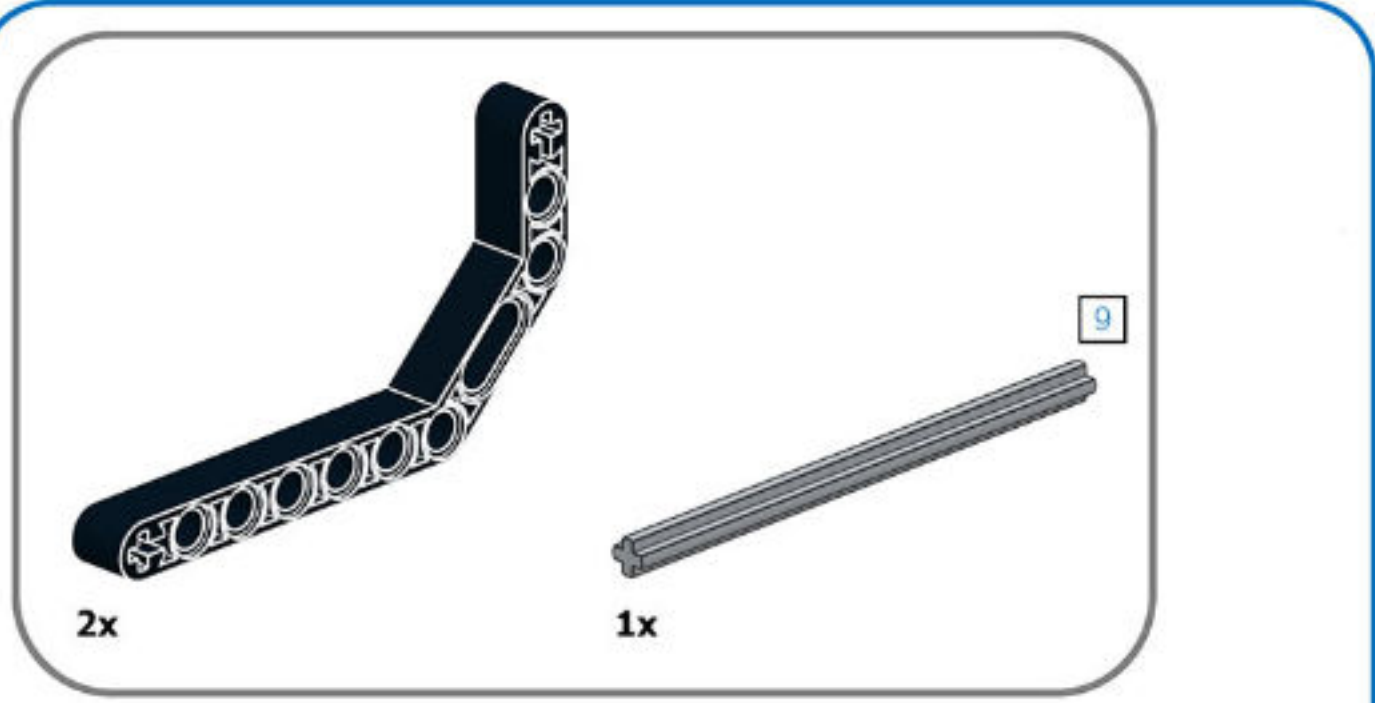
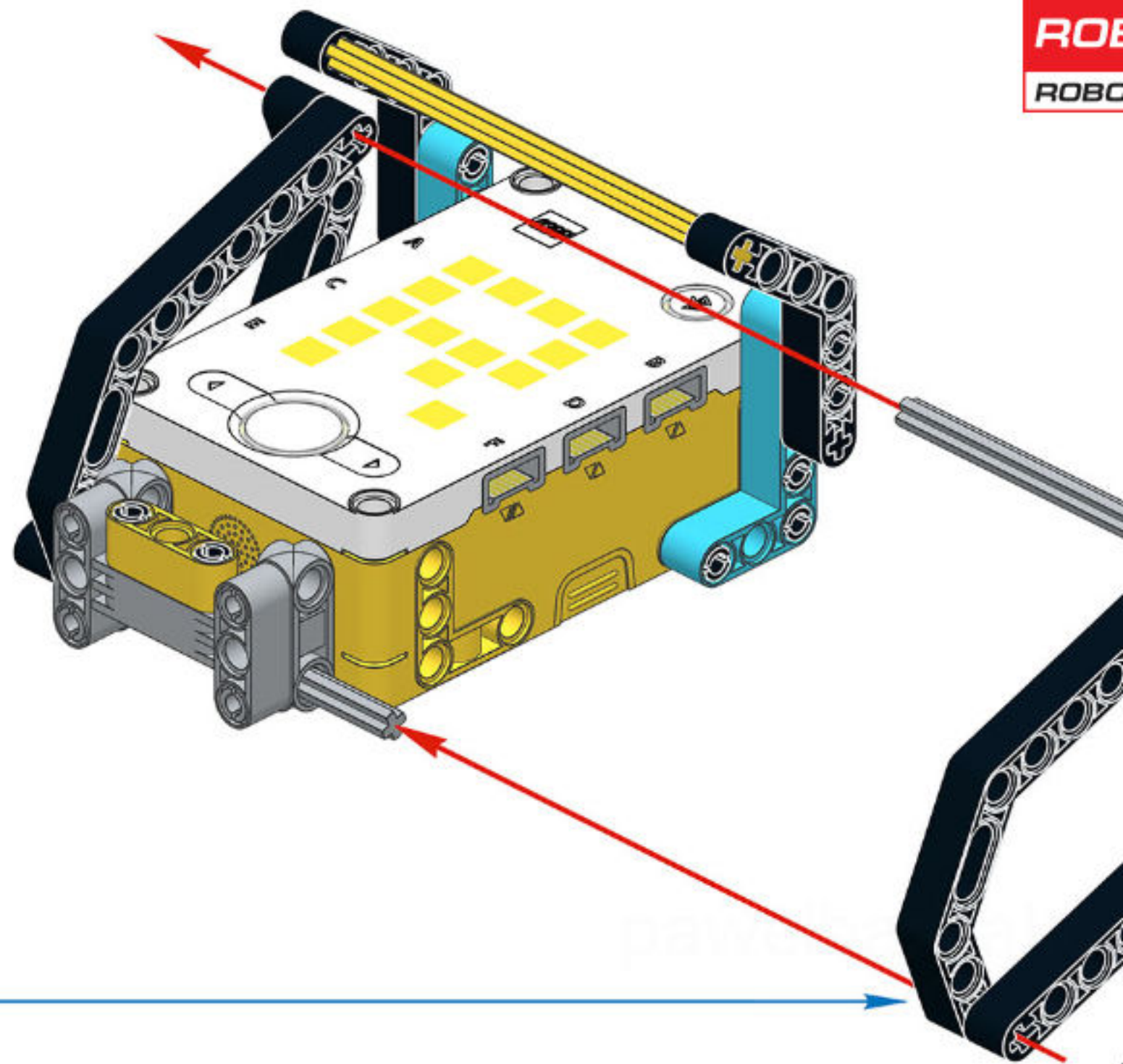

48/69

0

70

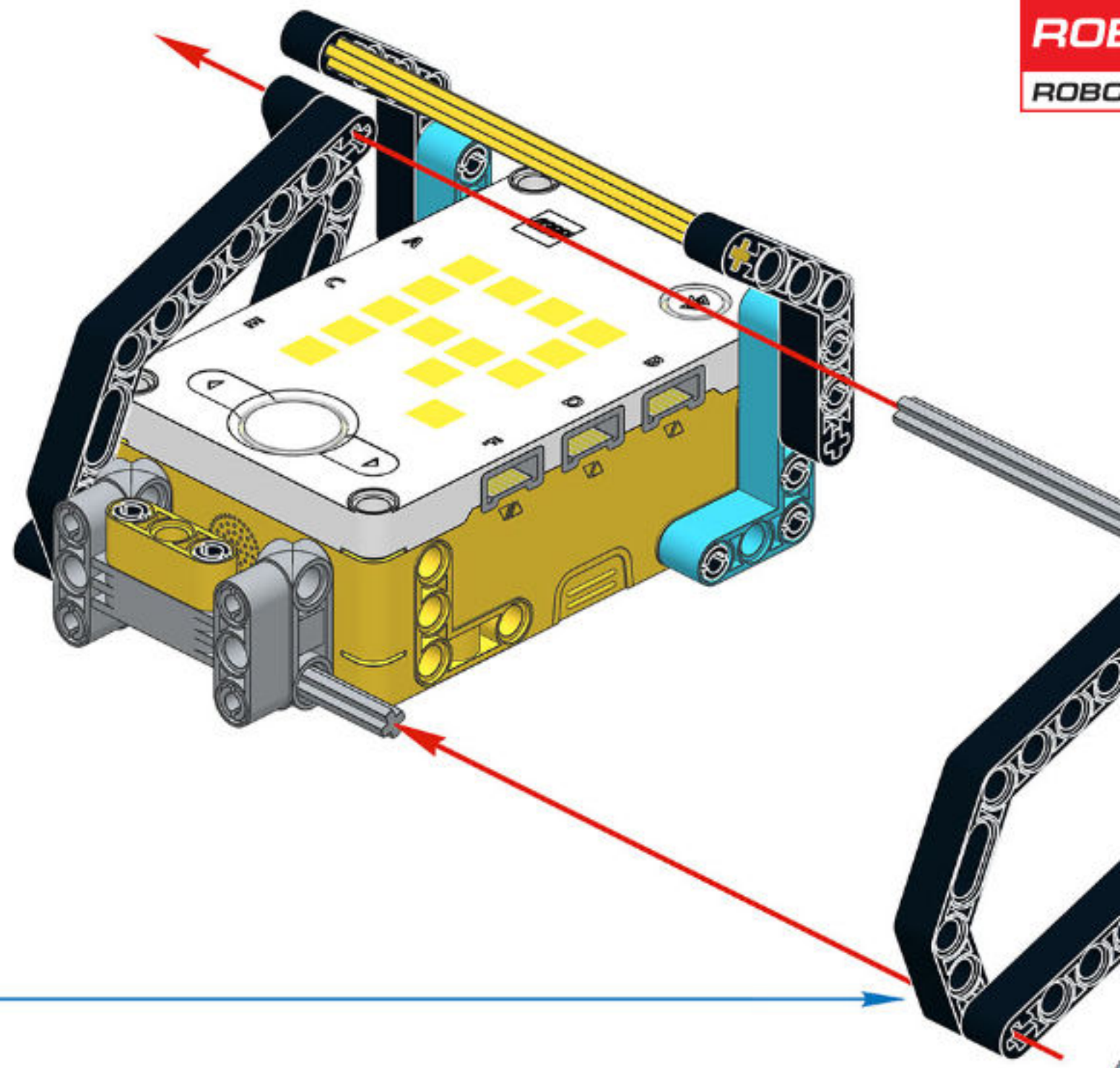
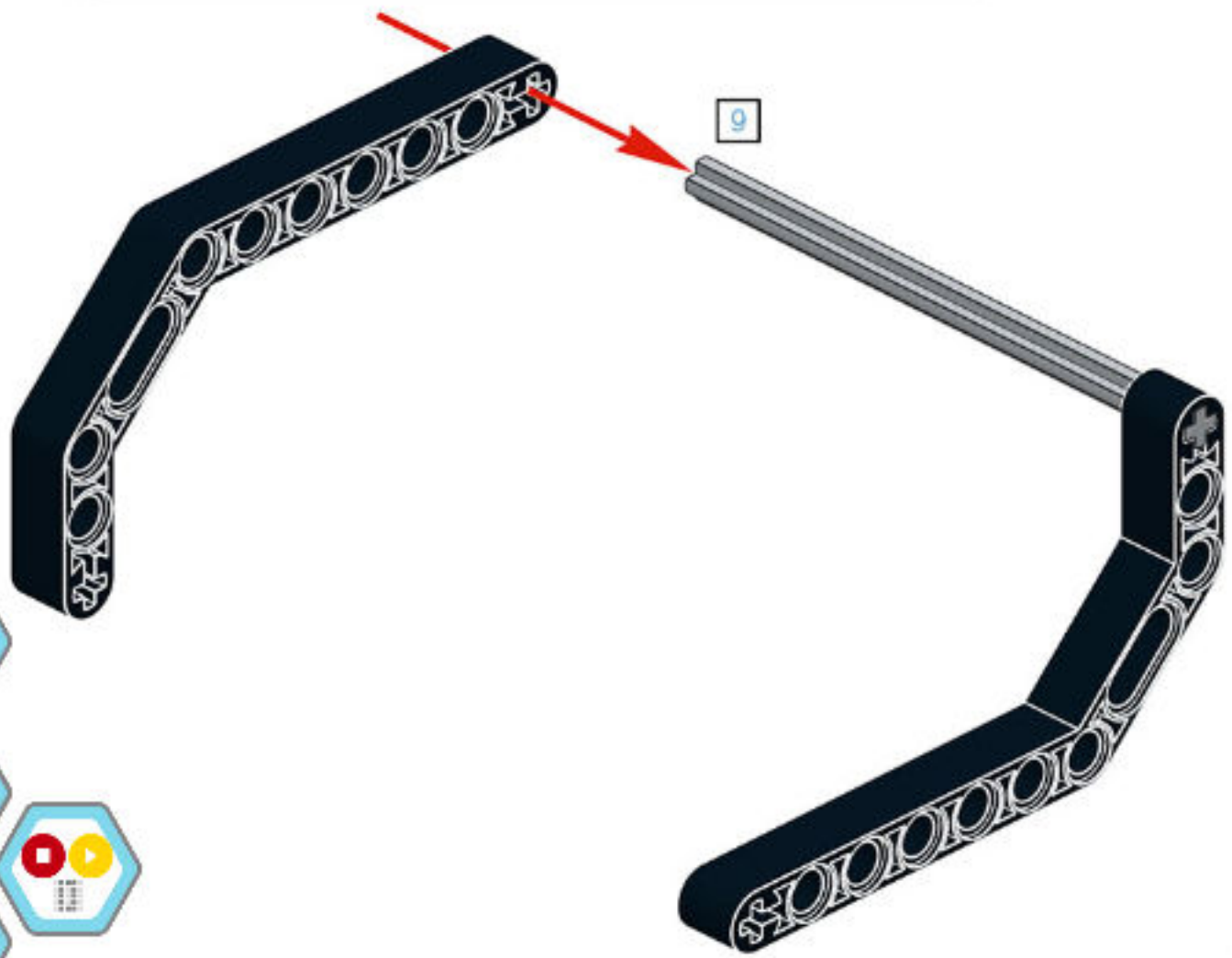
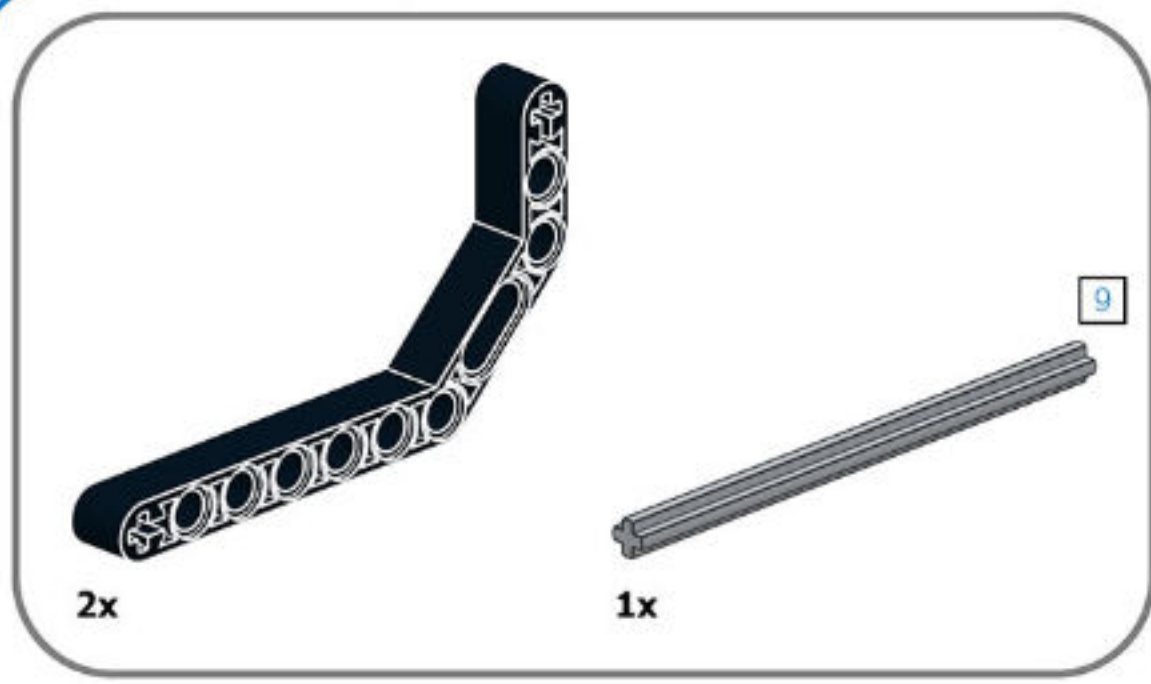

48/69

0

70



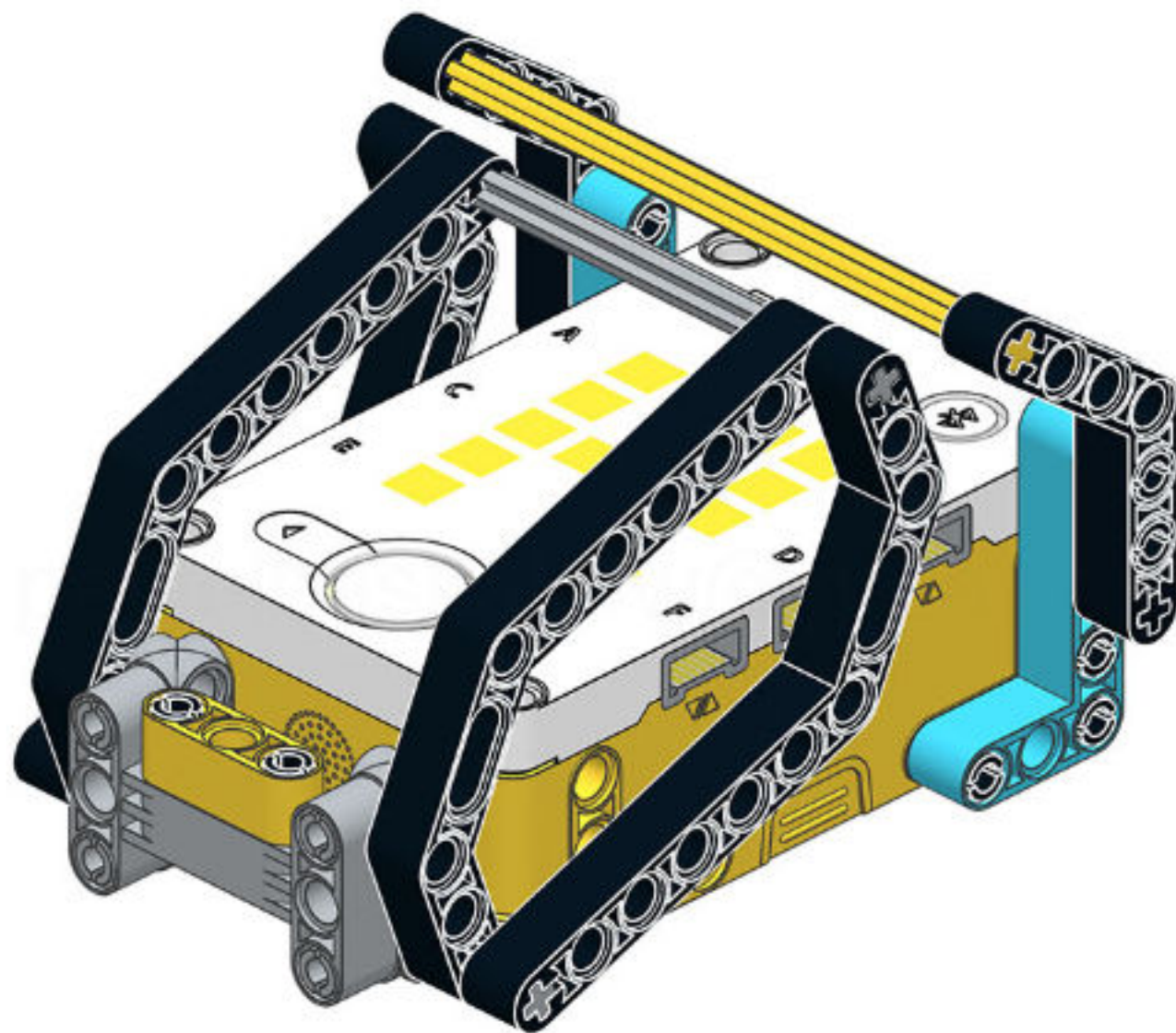

49

pawelbas

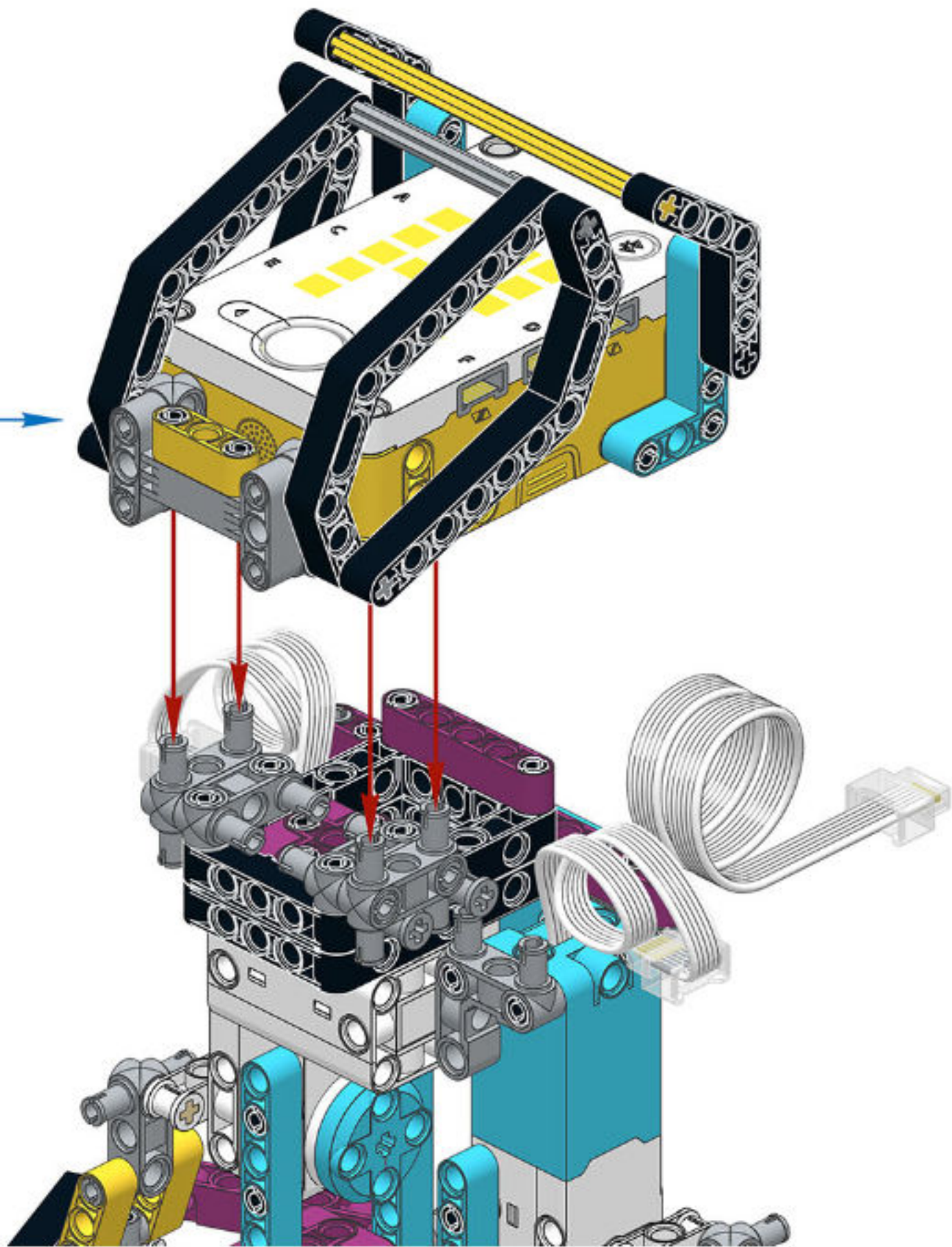

50/69

0

72

72

50

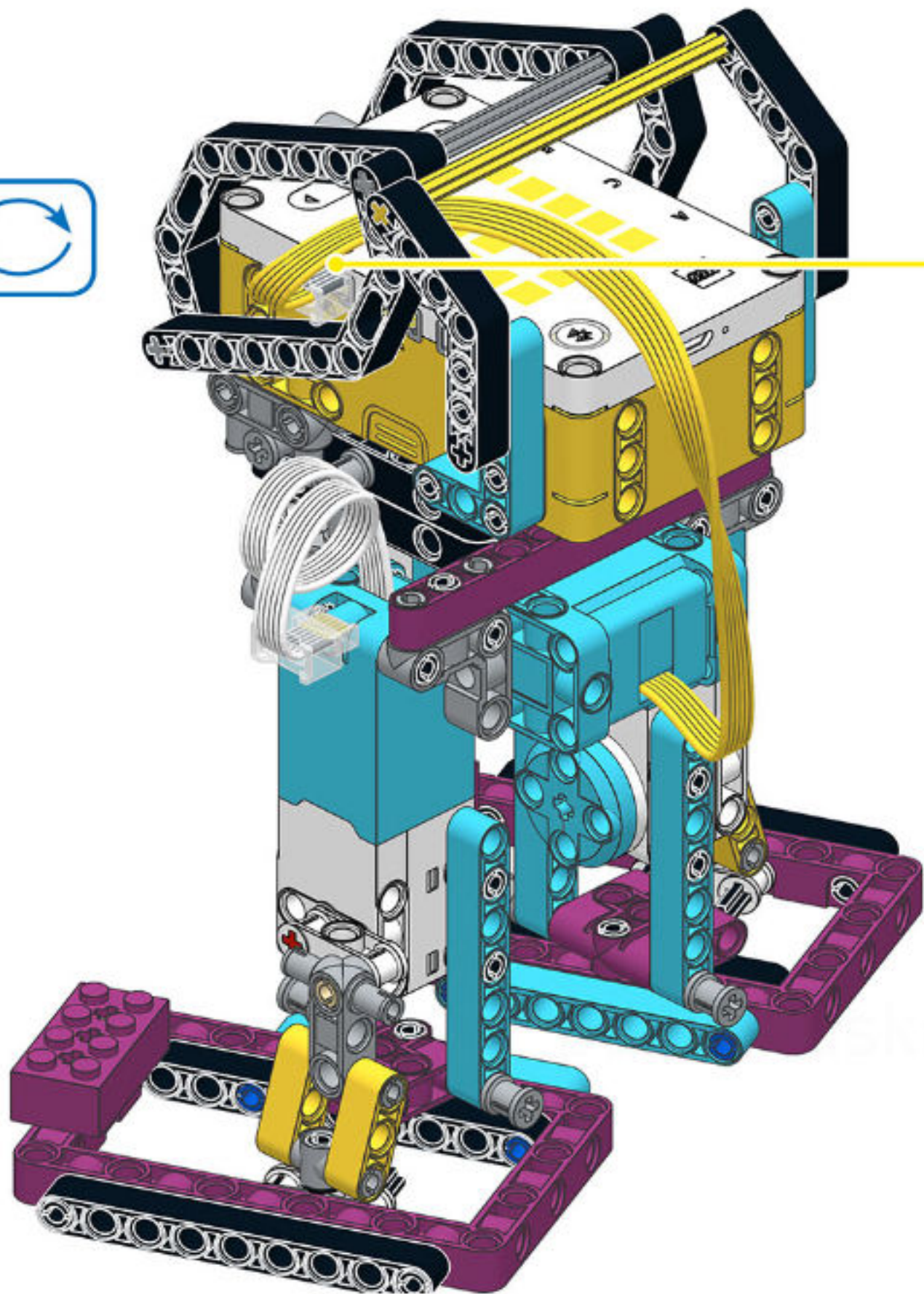

F



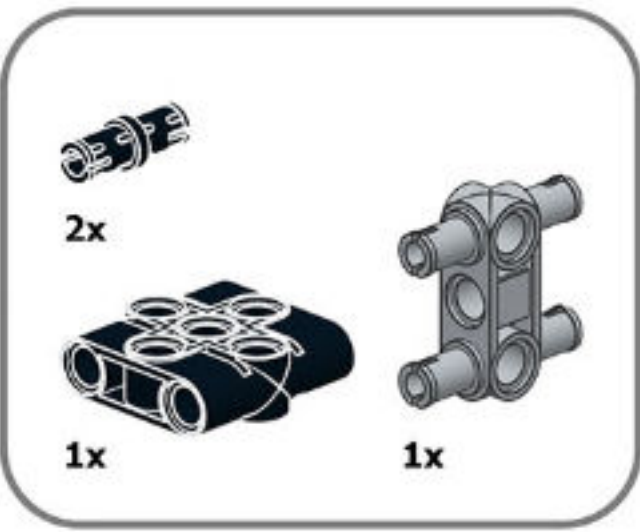
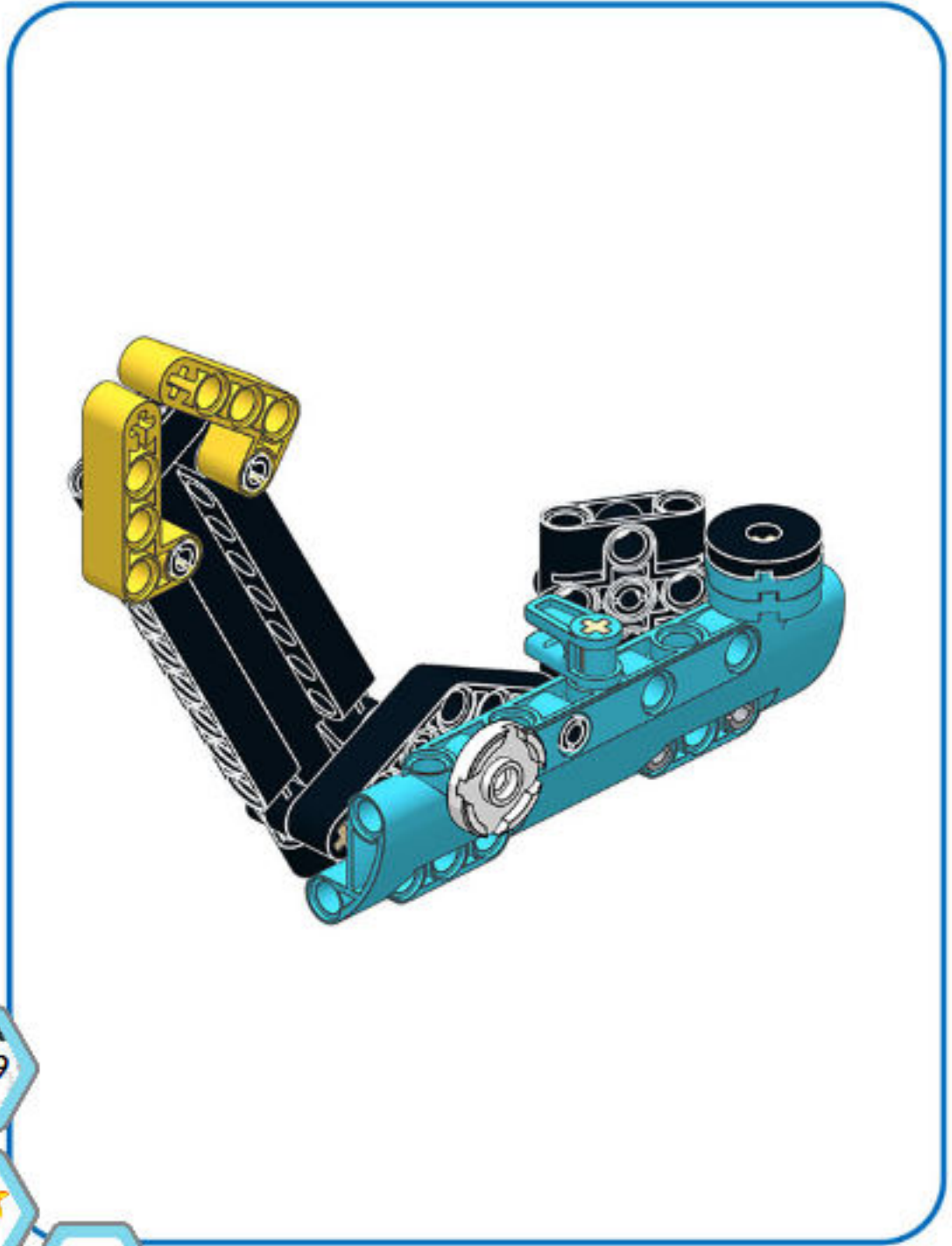

51

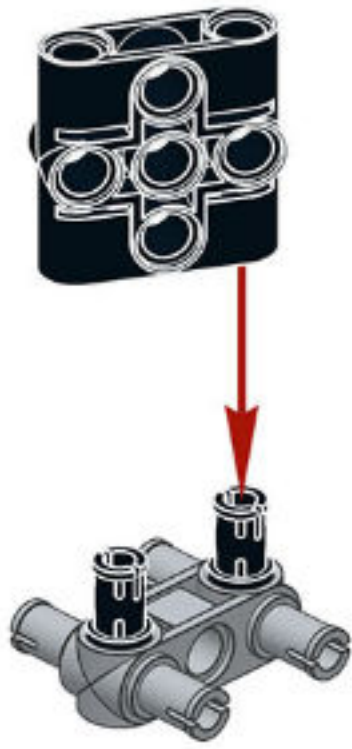

pawelbasko

52/69

0

74

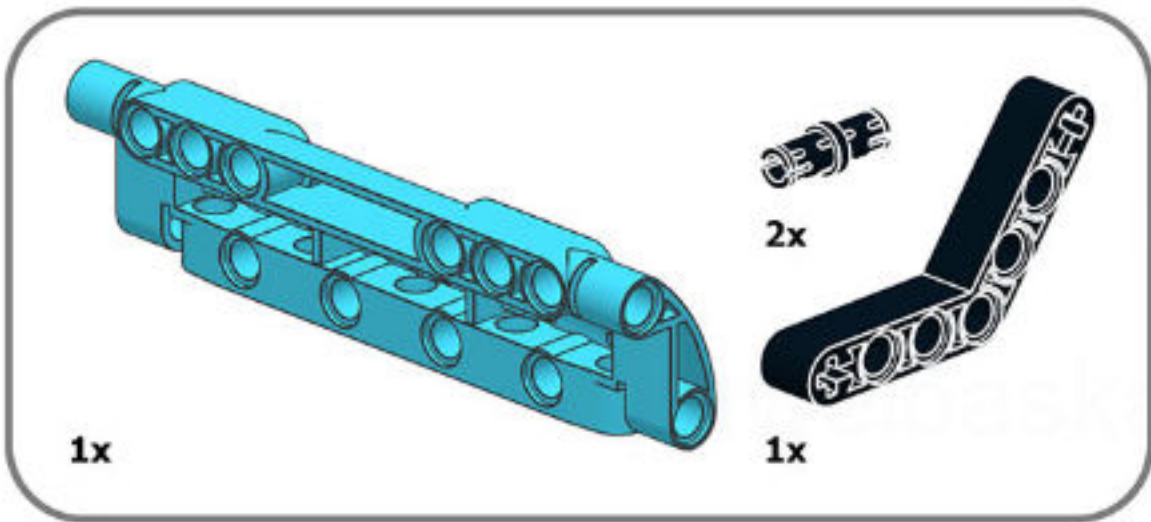

52

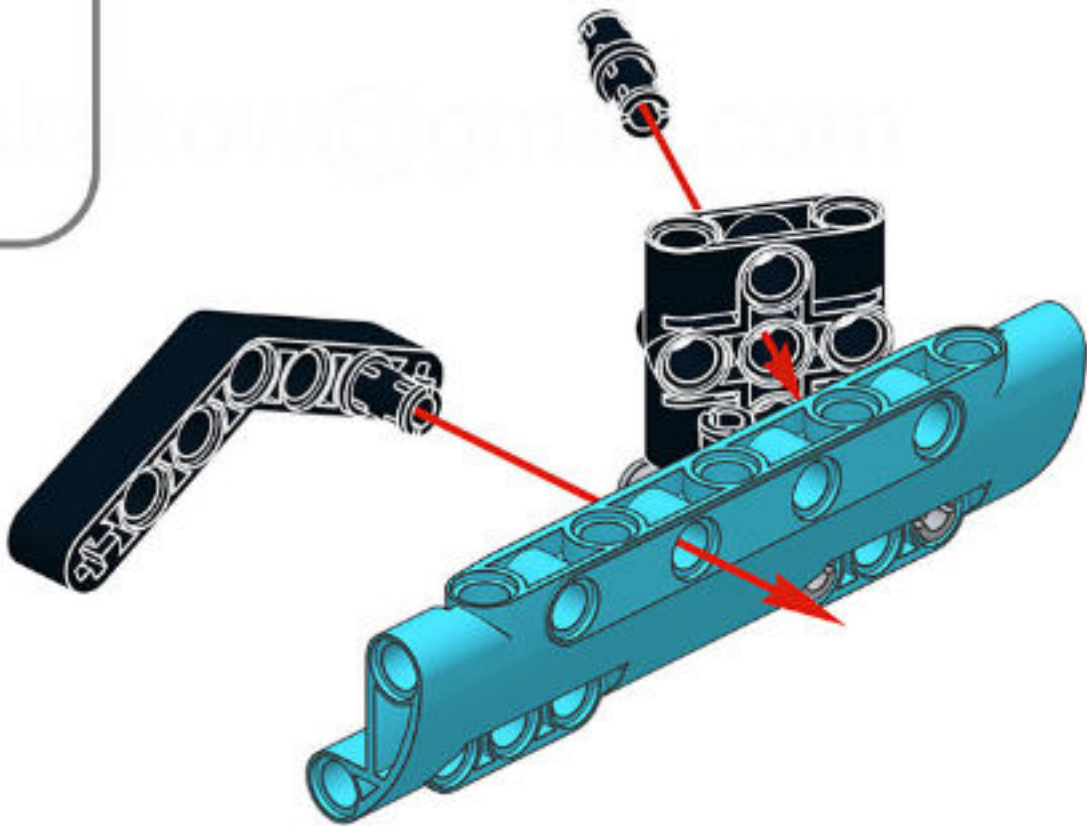

53/69

0

75

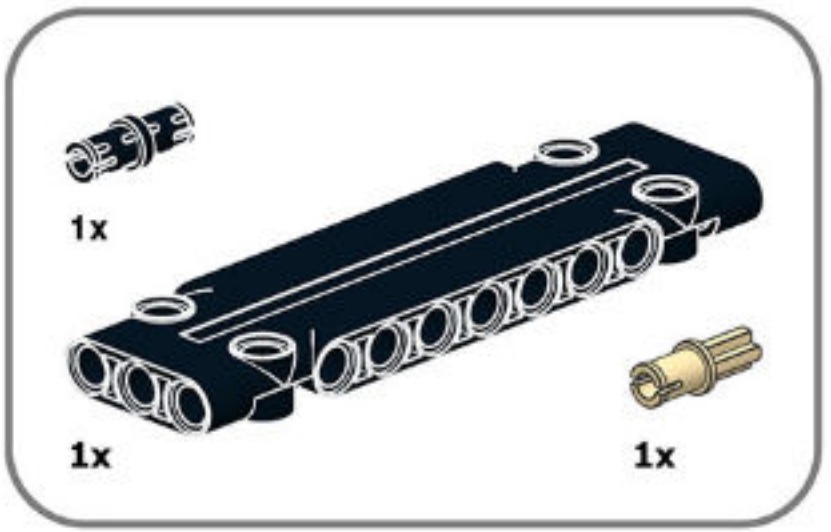

53

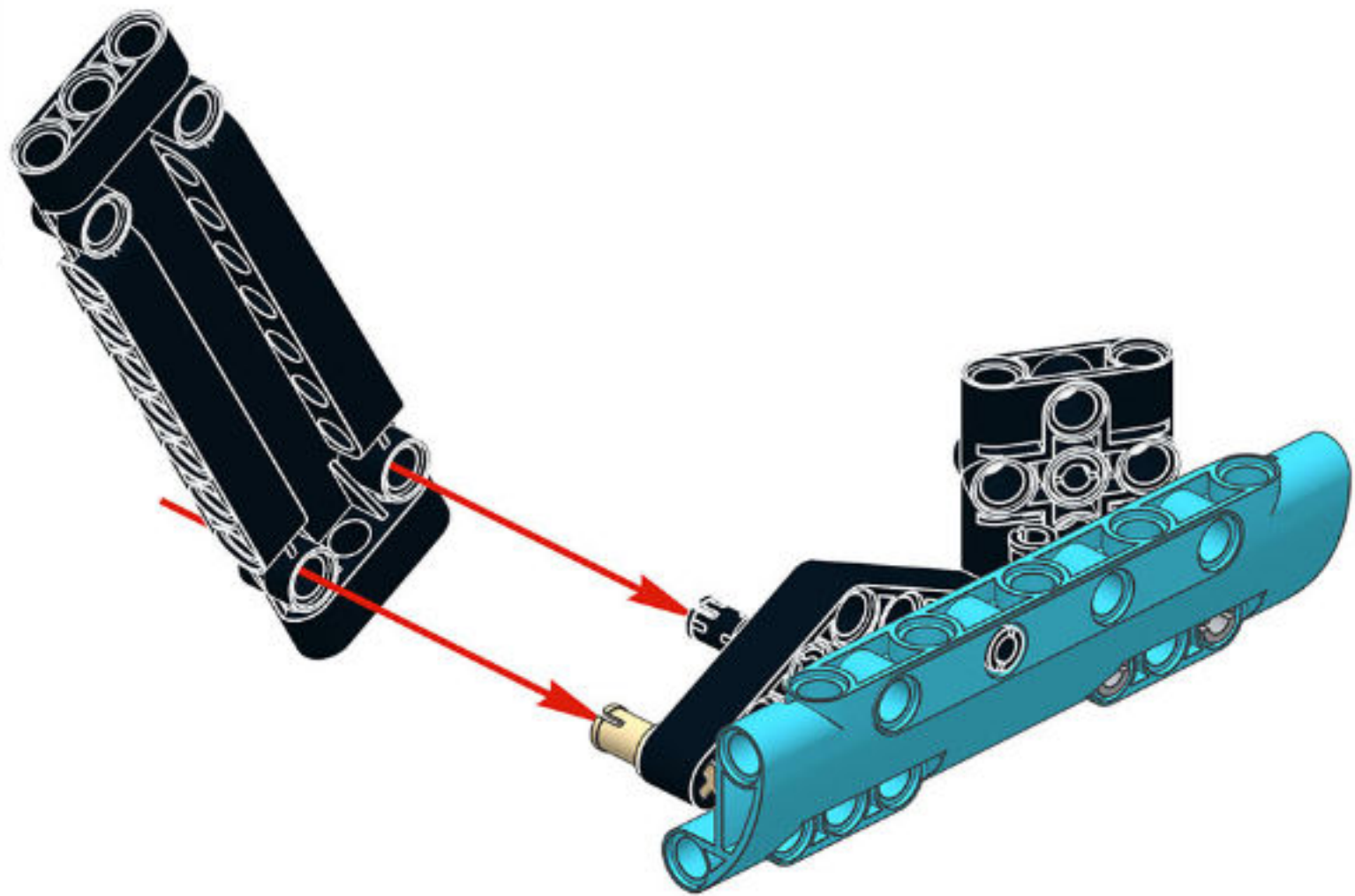

54/69
0
76

A set of navigation icons in the bottom left corner. It includes a hexagonal icon with '54/69', a yellow star icon with '0', and a hexagonal icon with '76'. There are also small icons for a pencil and a magnifying glass.

pawelbaskakov@gmail.com

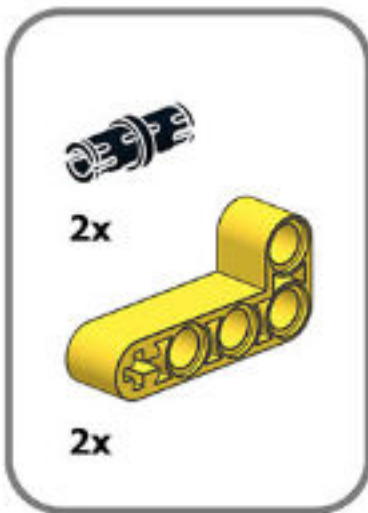

54

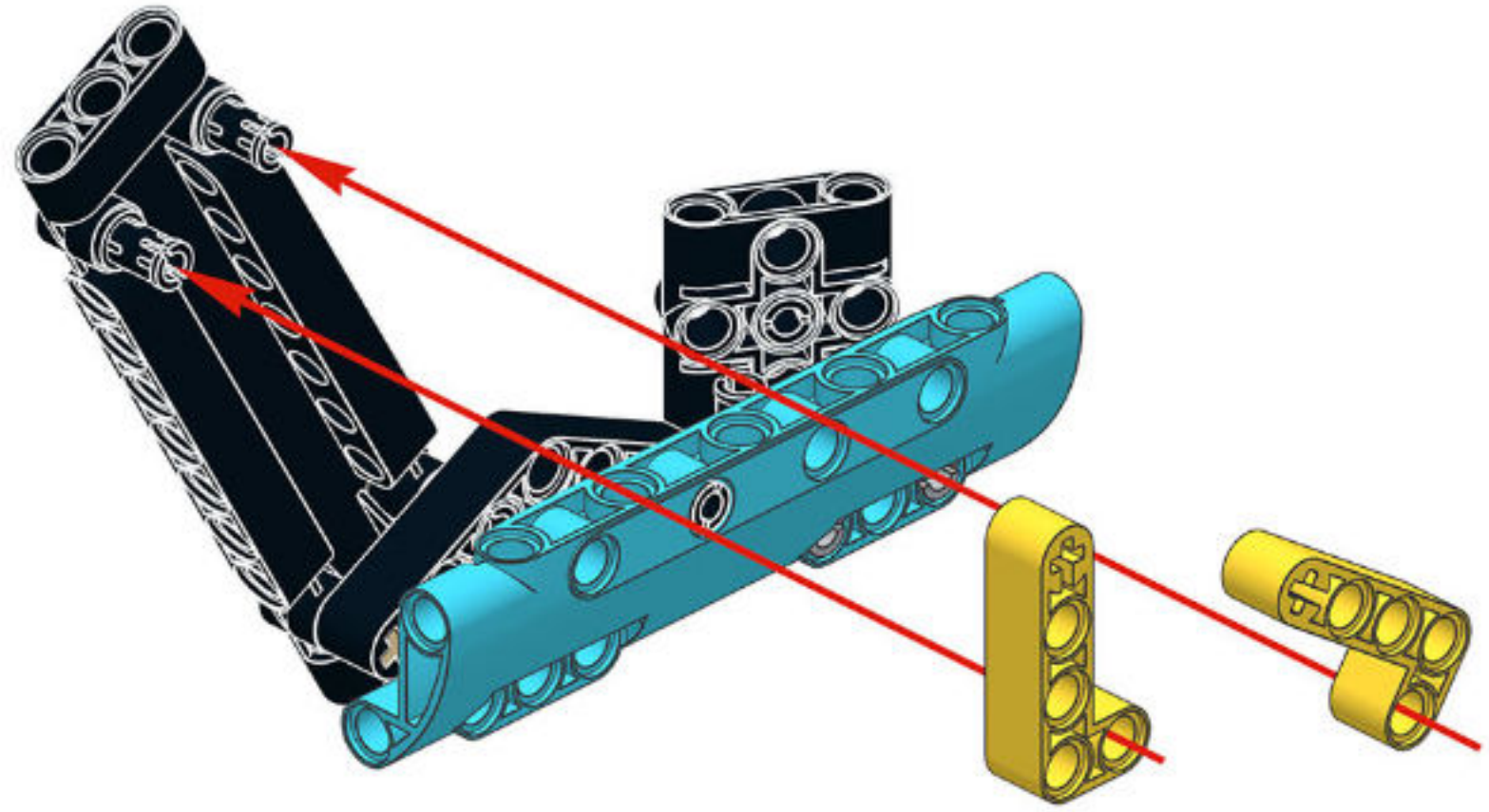

55/69
0
77

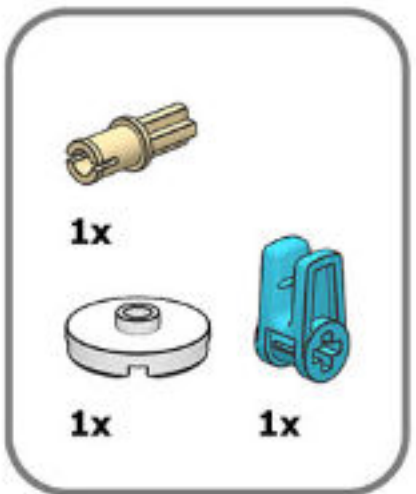

55

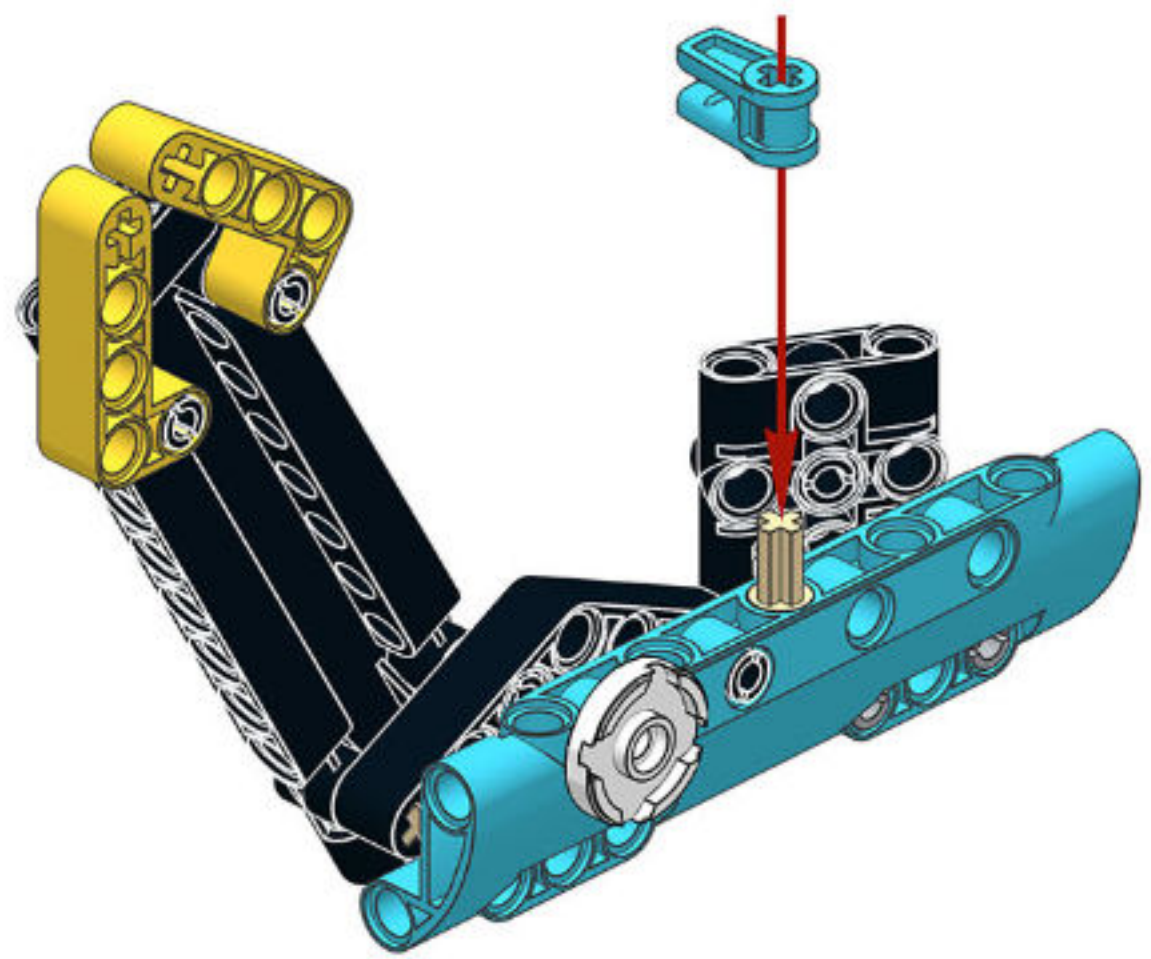

pavelbaskakov

56/69
0
78

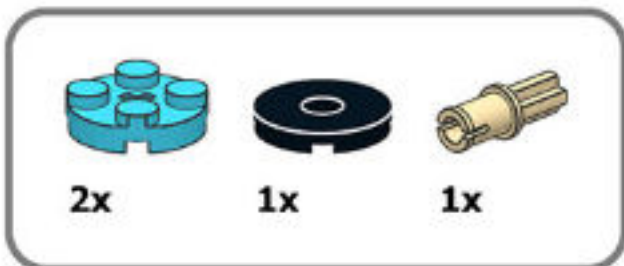

56

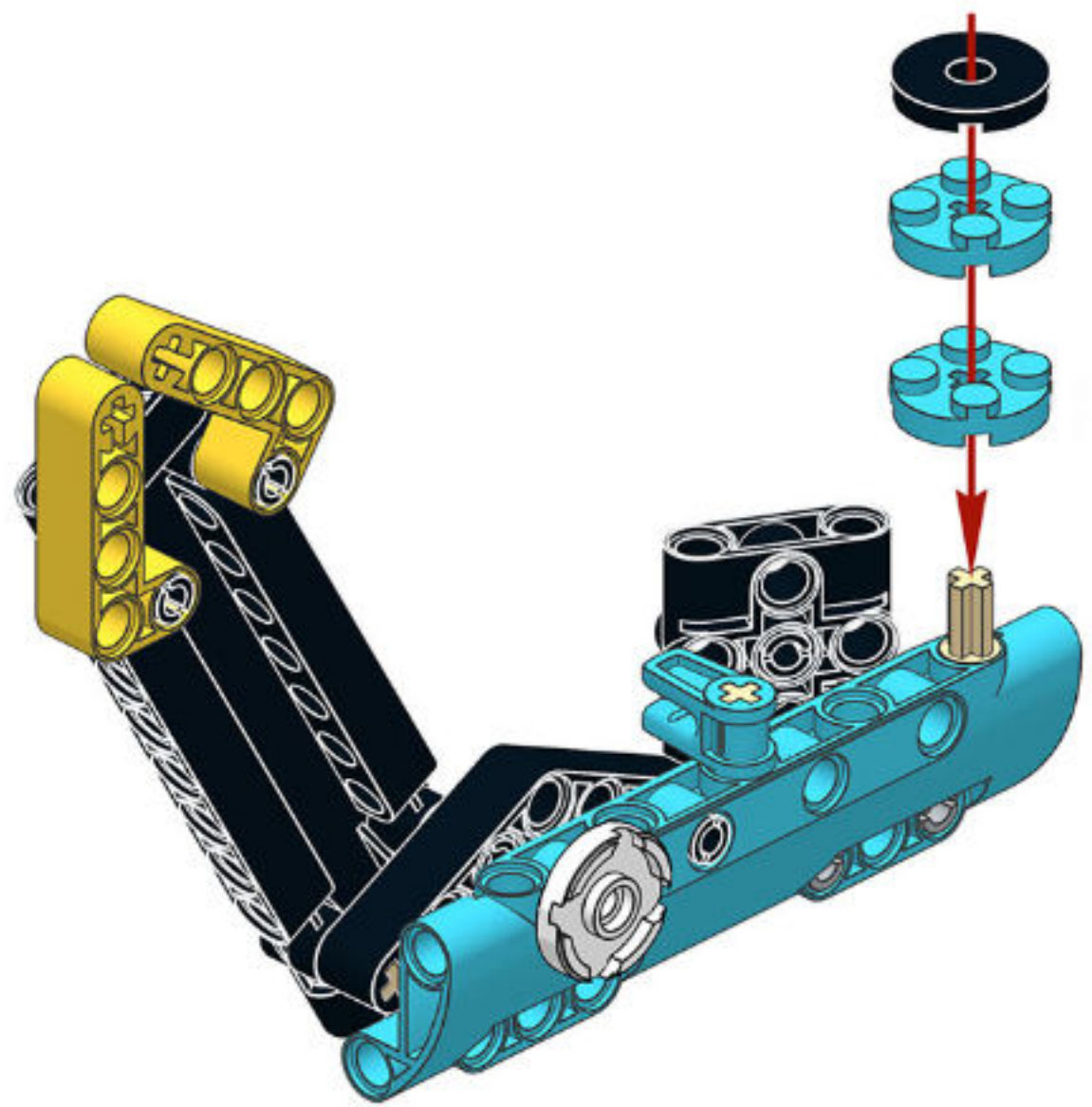

havelbaskakow@p

57/69

0

79

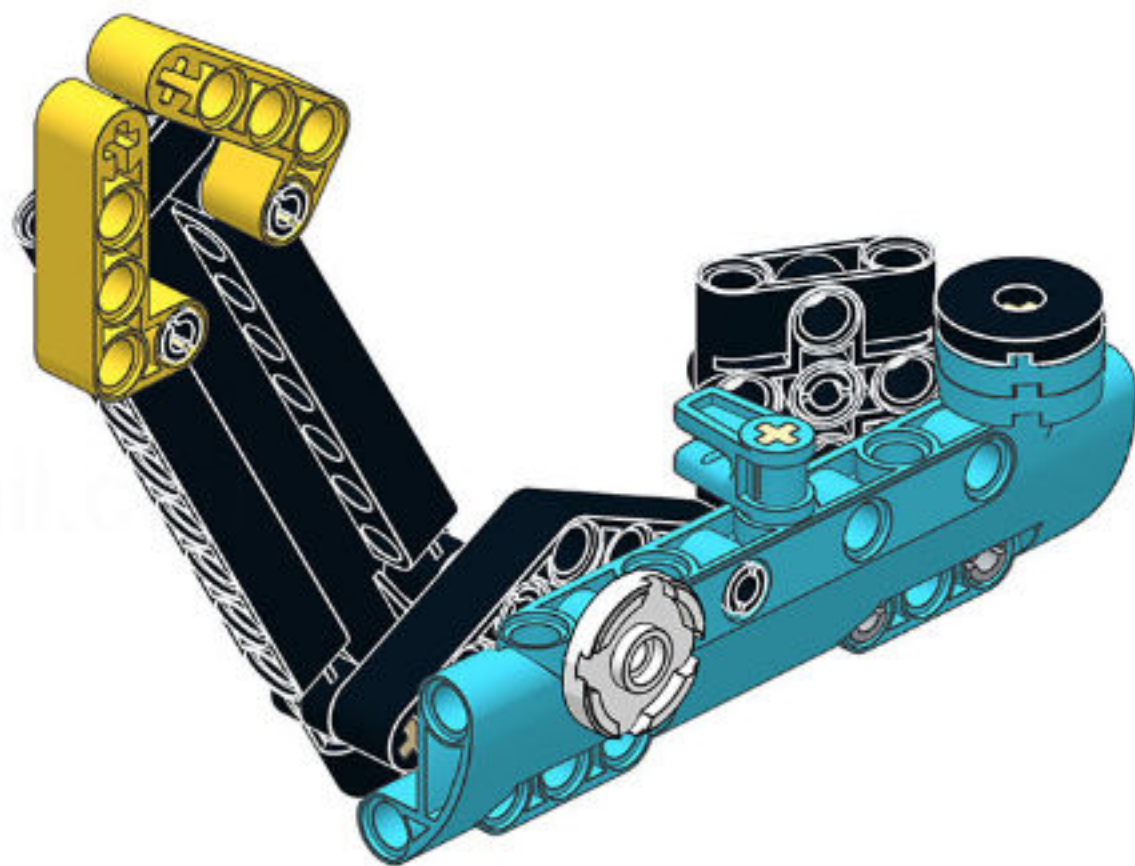

pawelbaskakow@gmail.com



58

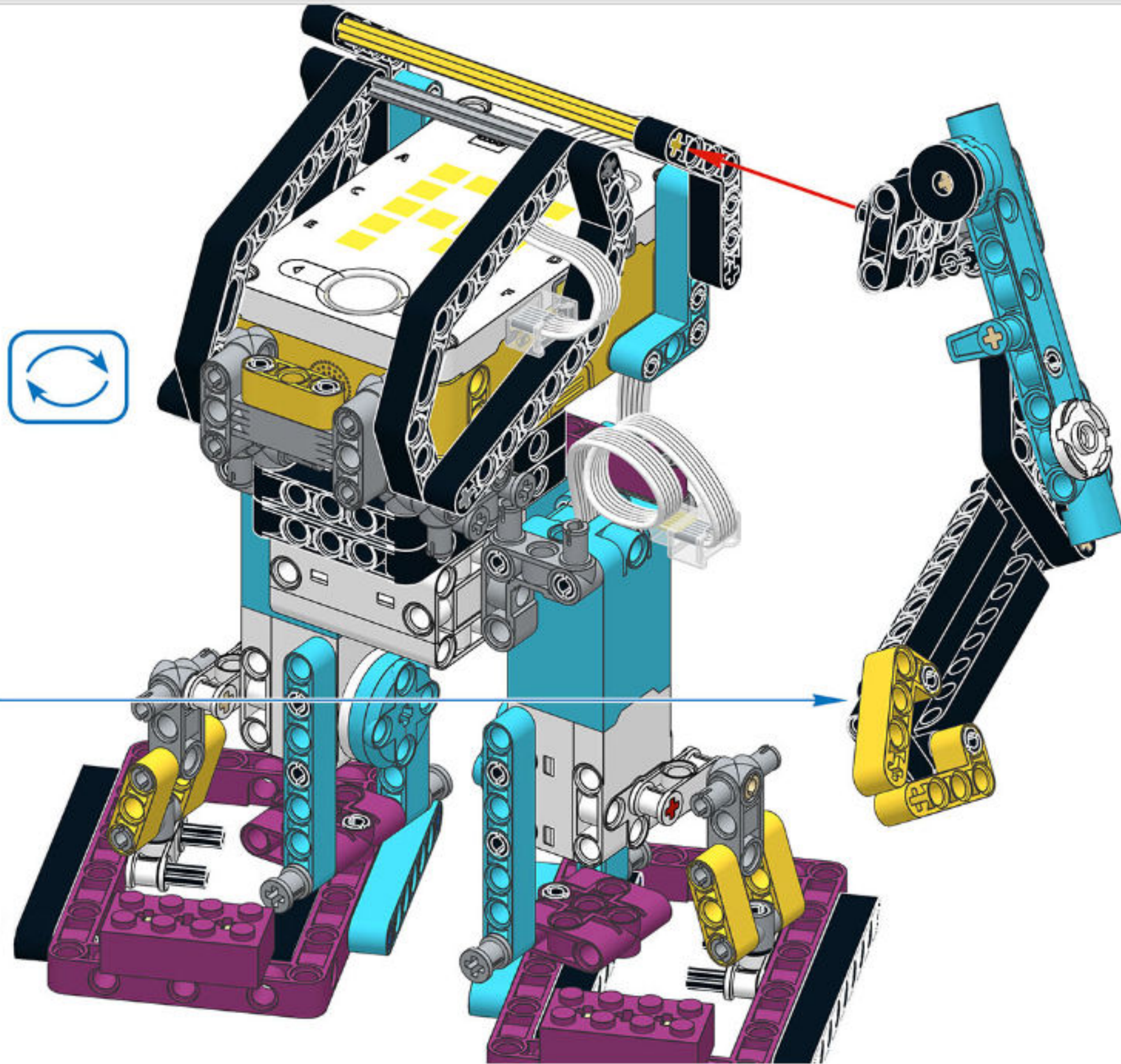

59/69

0

81

59

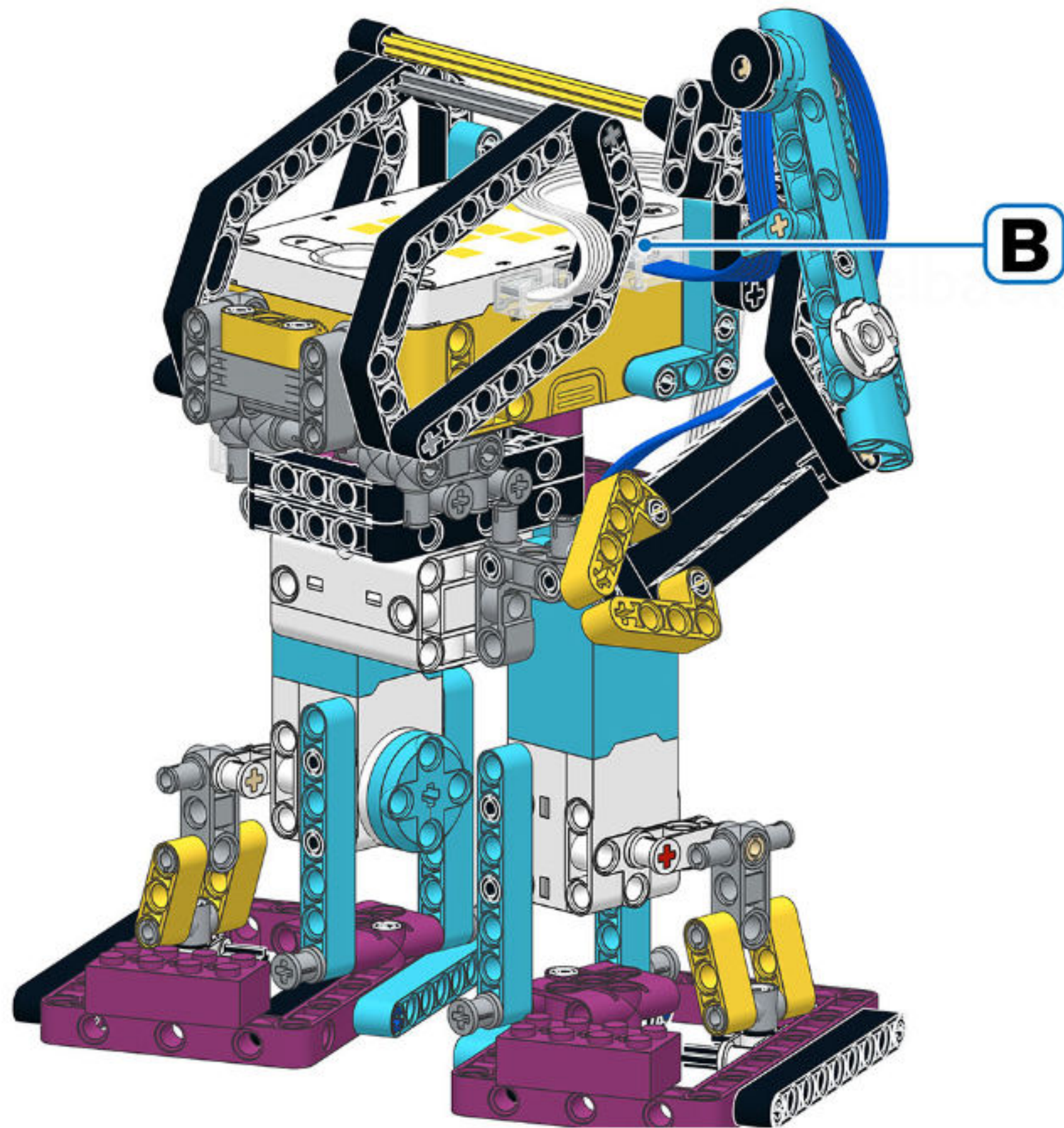

60/69

0

82



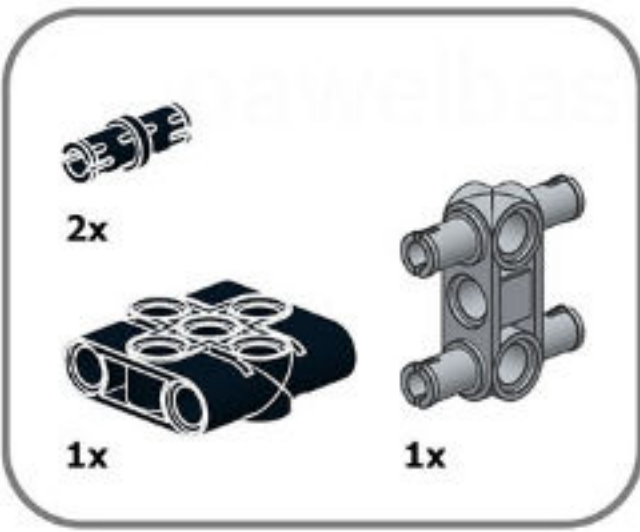
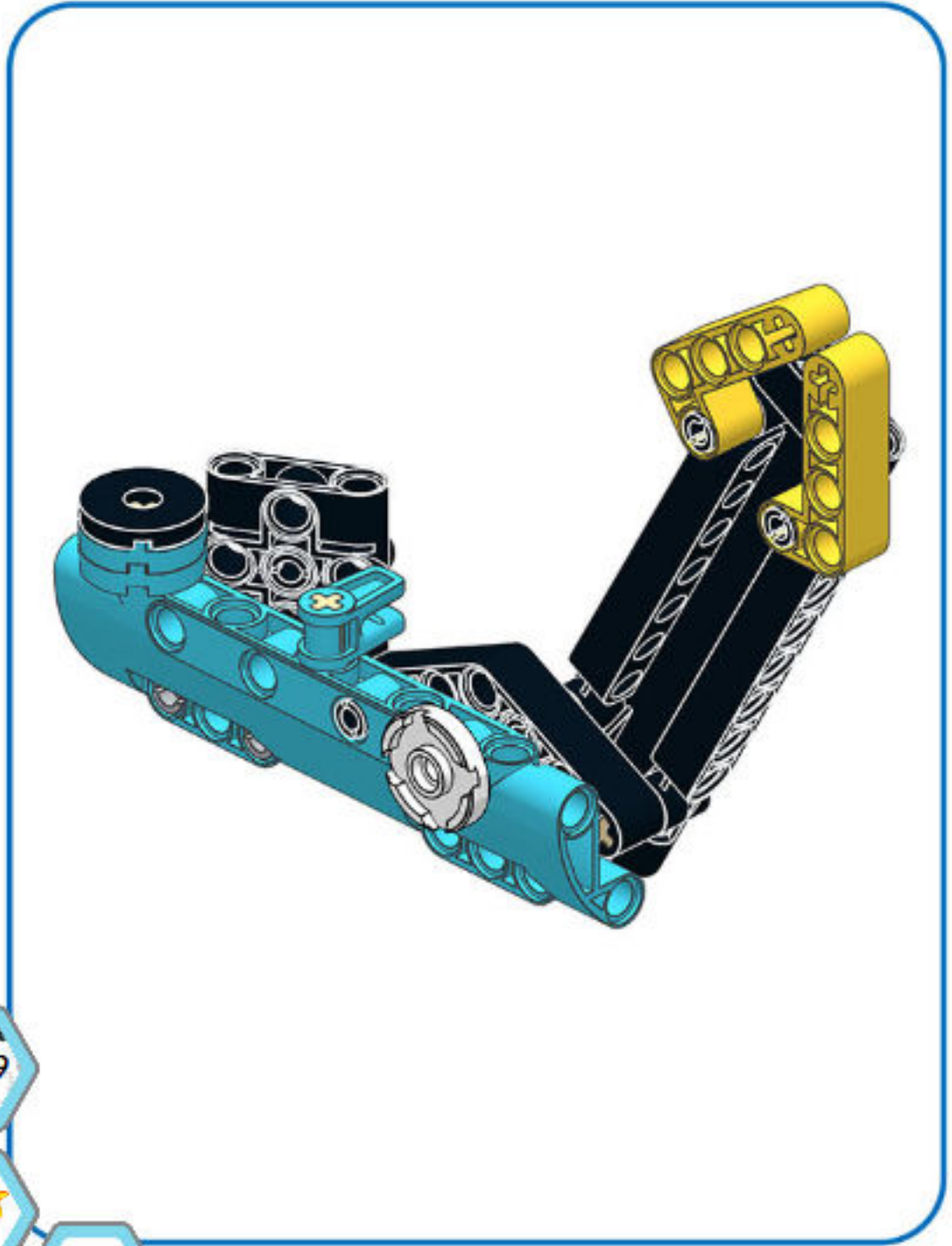

60

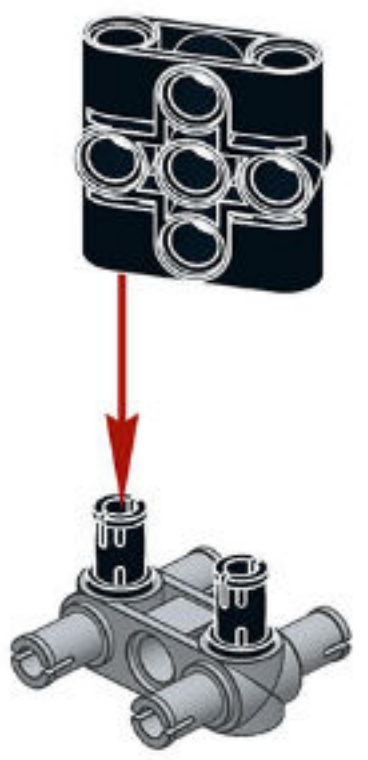

61/69

0

83

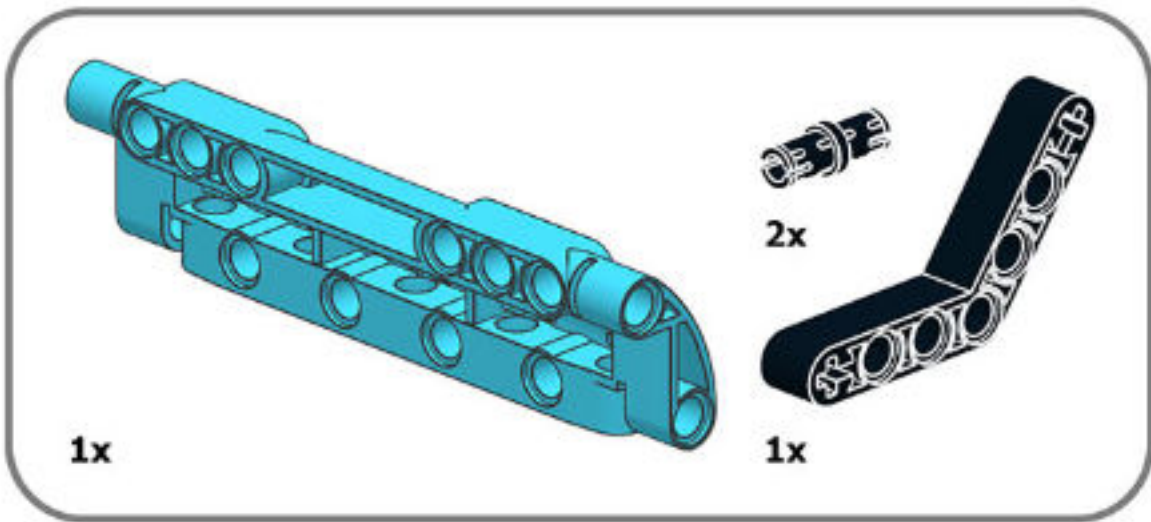

61

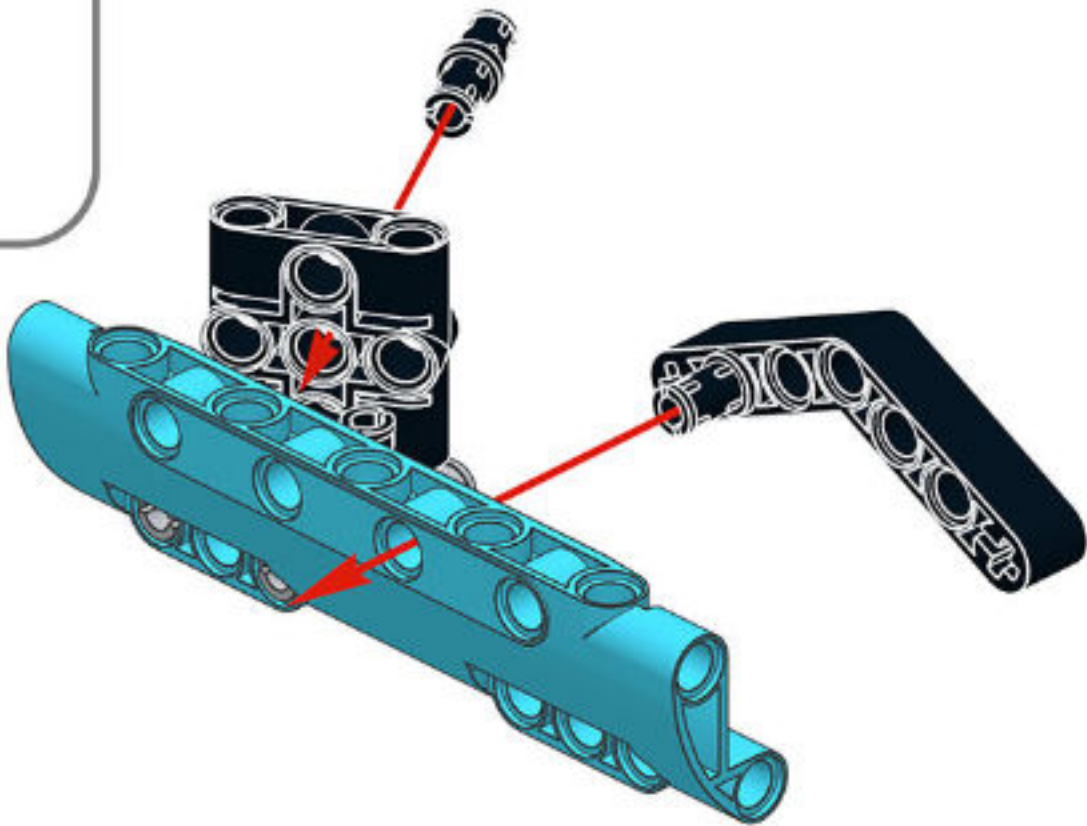

62/69

0

84

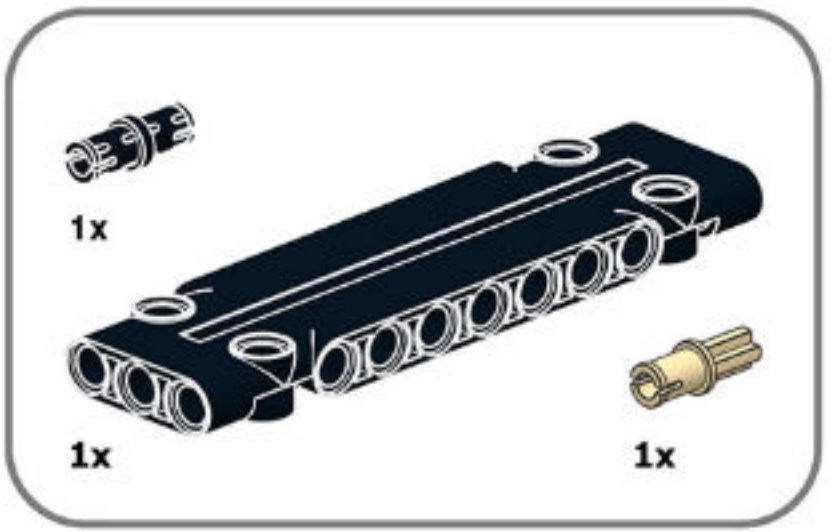

62

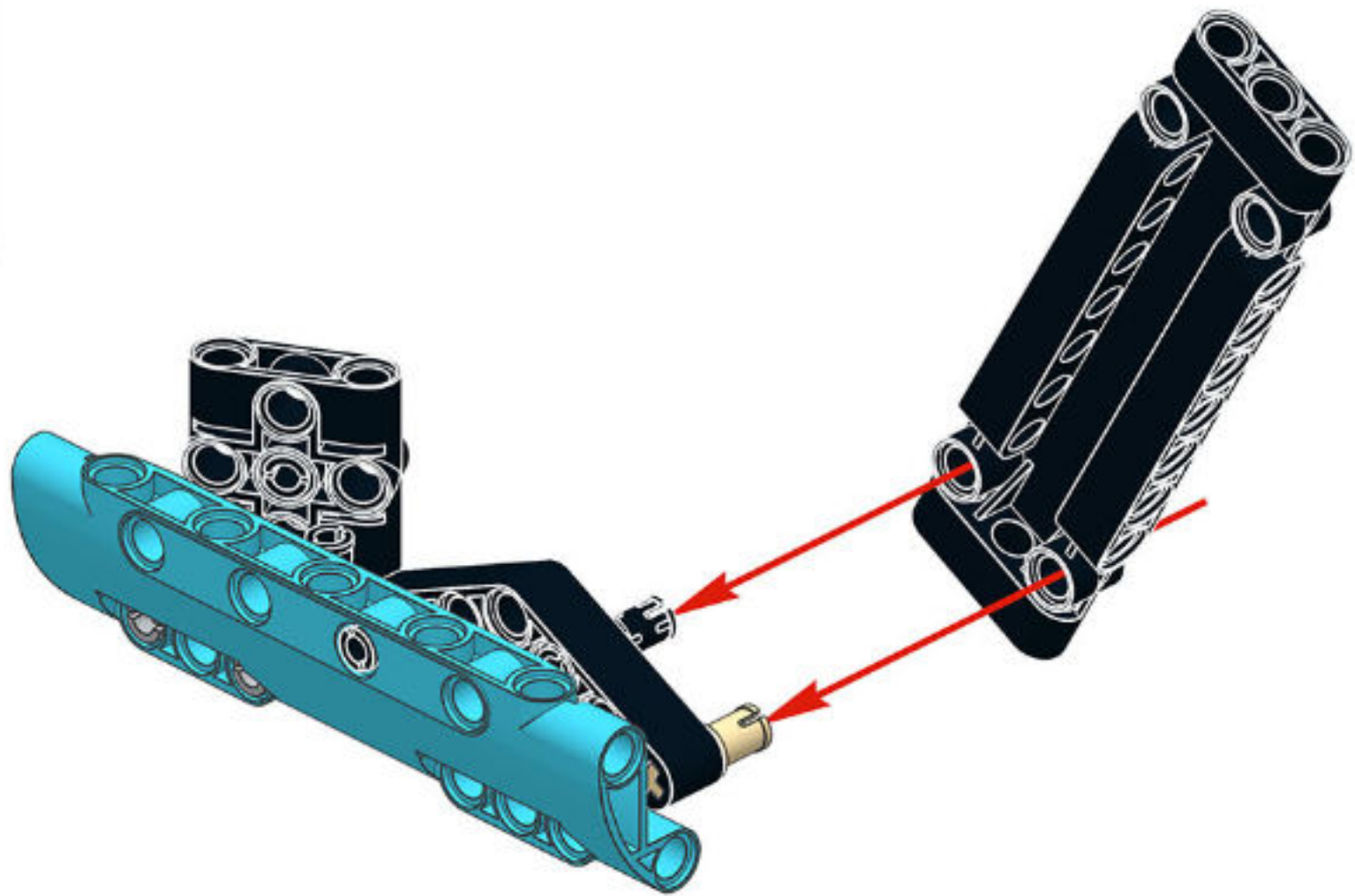

63/69
0
85

This block contains navigation icons: a blue hexagon with '63/69', a yellow hexagon with '0', and a blue hexagon with '85'. There are also icons for a red and yellow circle and a blue square with a white cross.

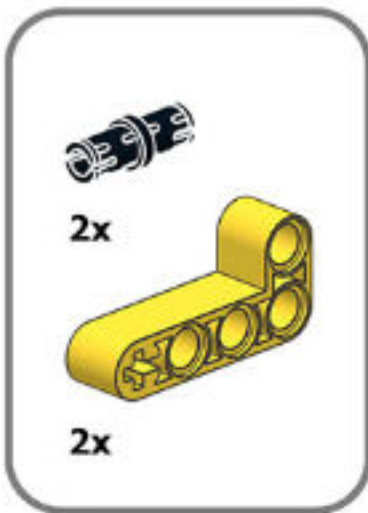

63

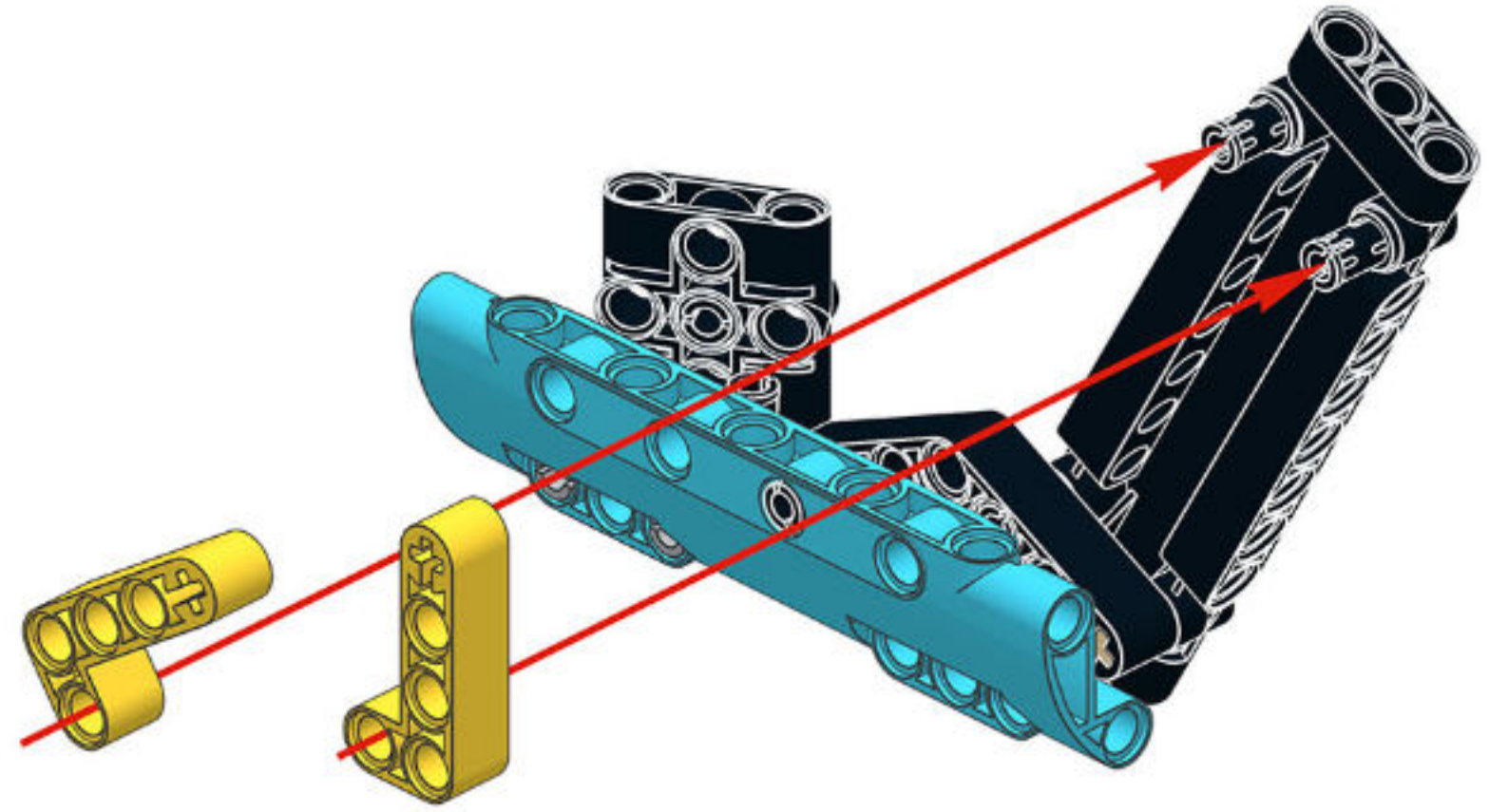

64/69
0
86

webaskakow@gmail.com

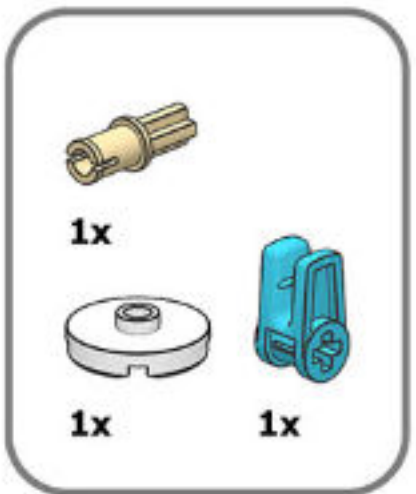

64

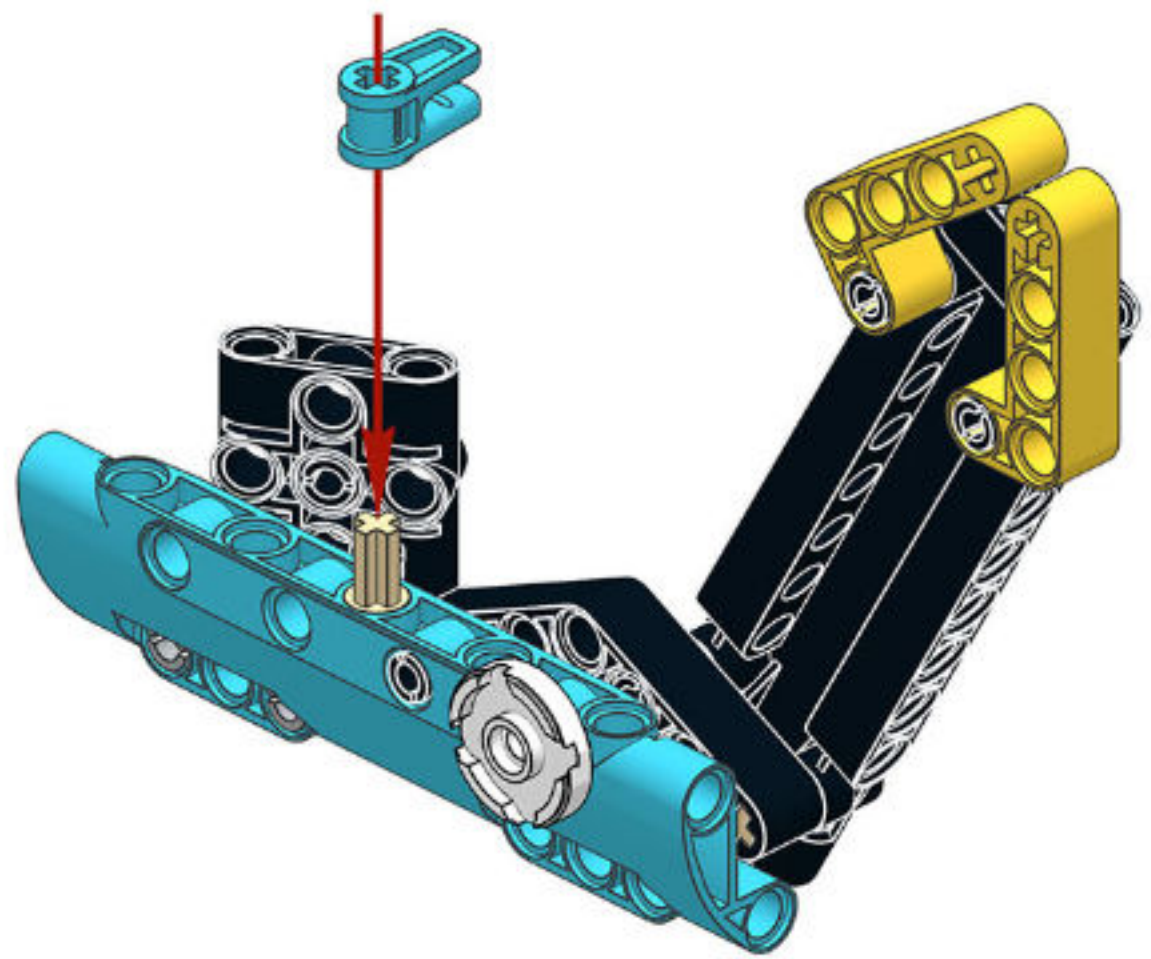

pavebaskaku

65/69

0

87

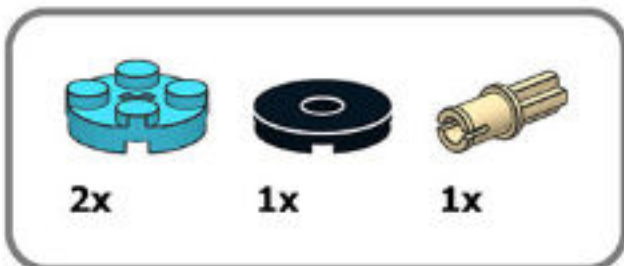

65

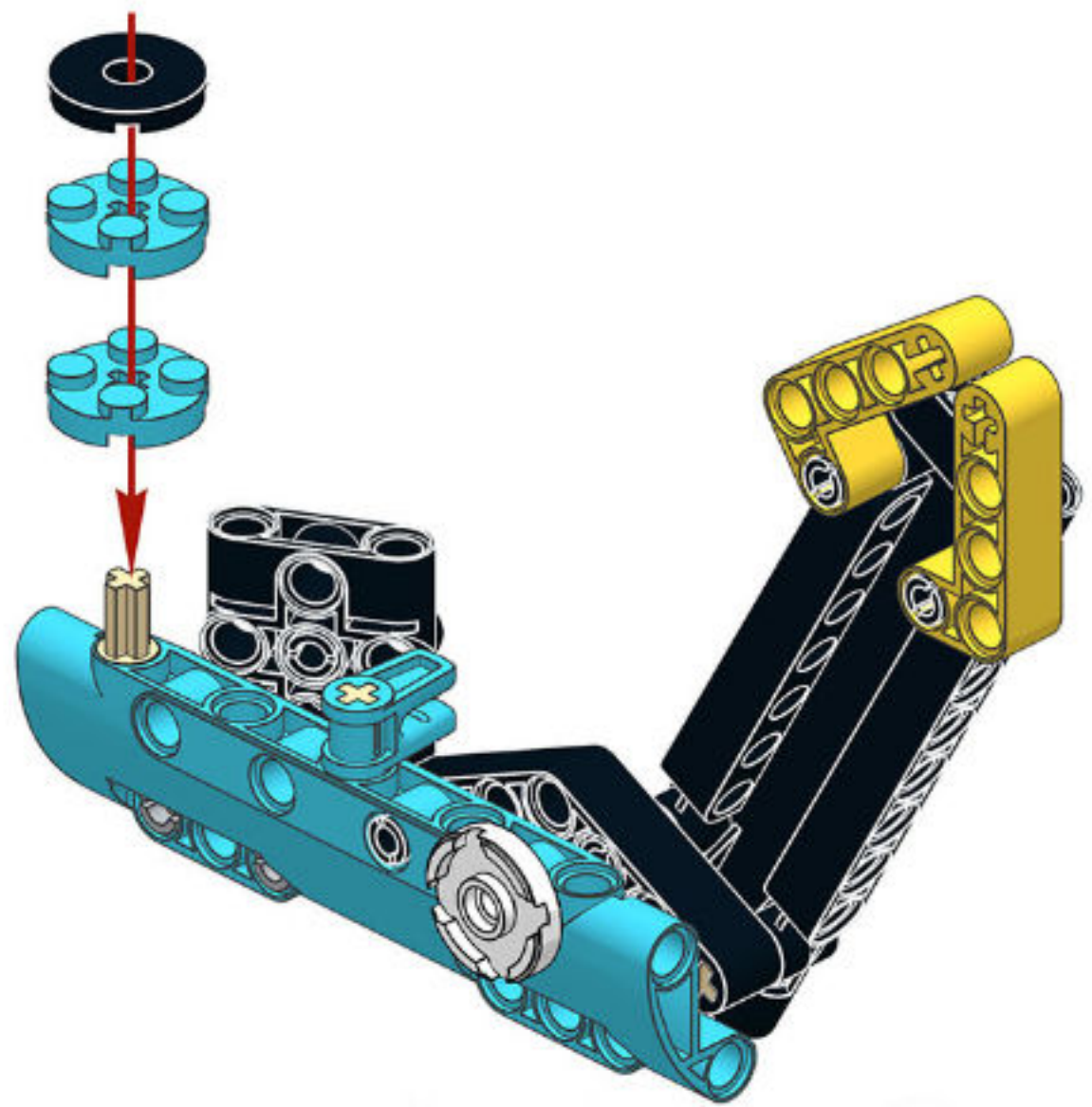

patel@esrakov@gmail.com

66/69
0
88

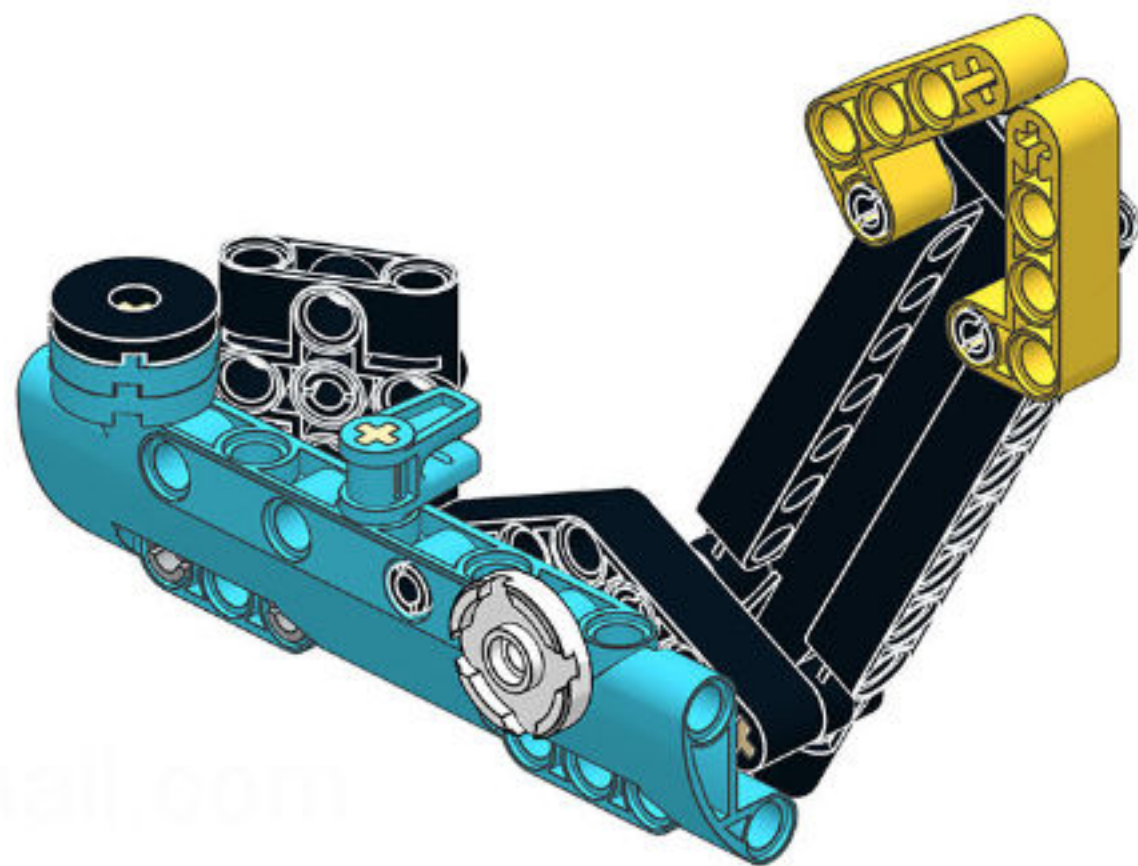

pawelbaskakow@gmail.com



67

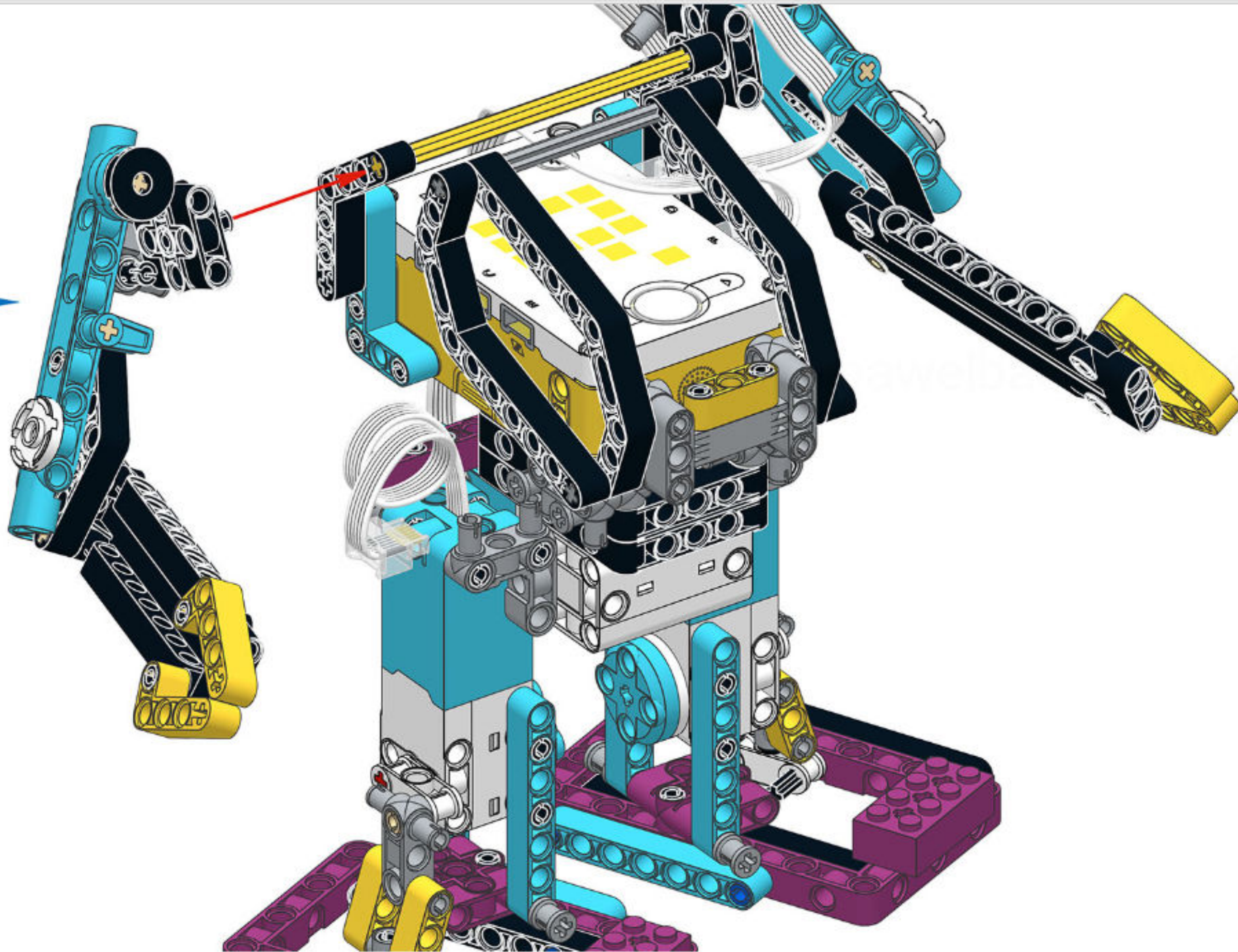

A

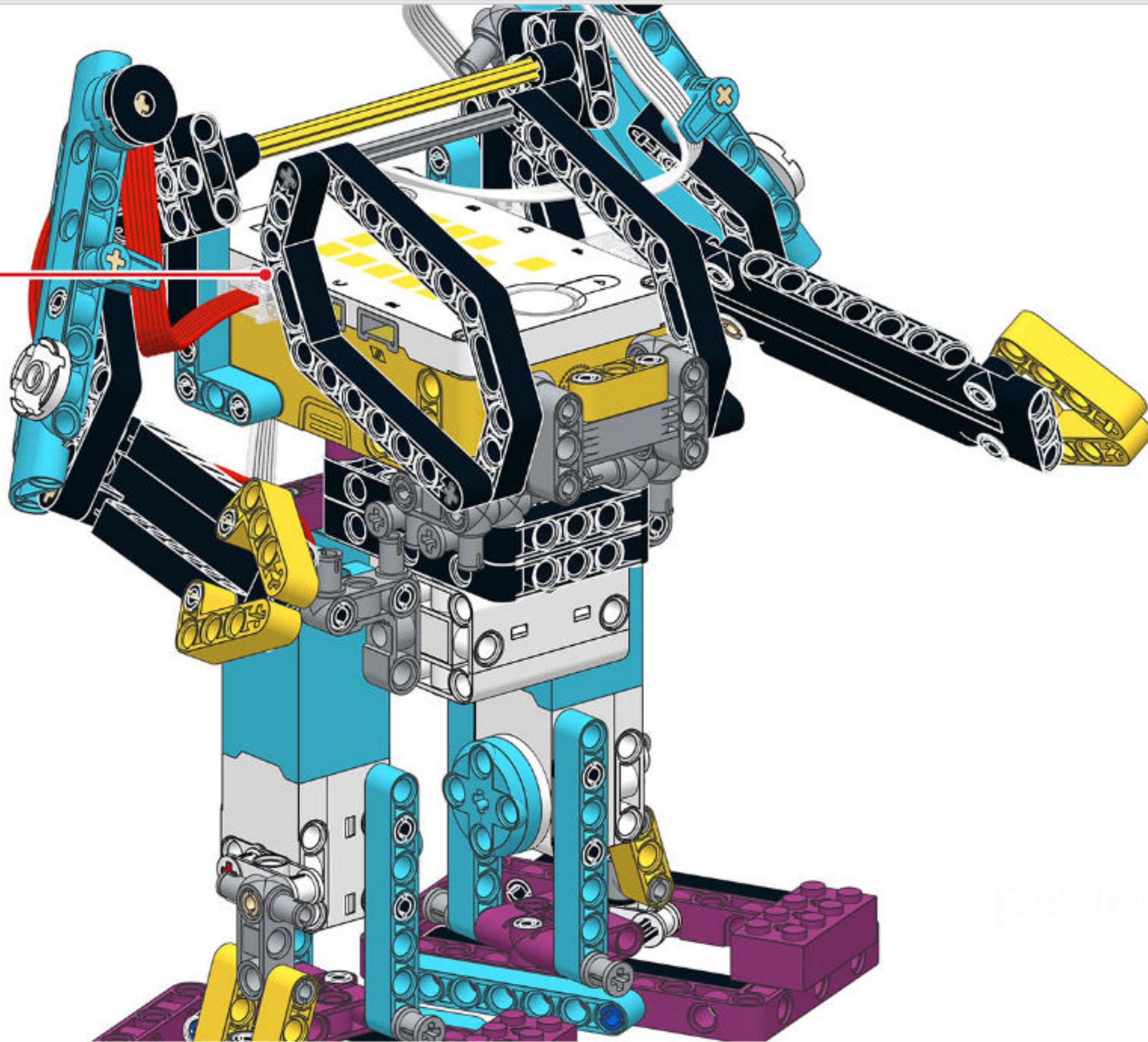

naveleostakov

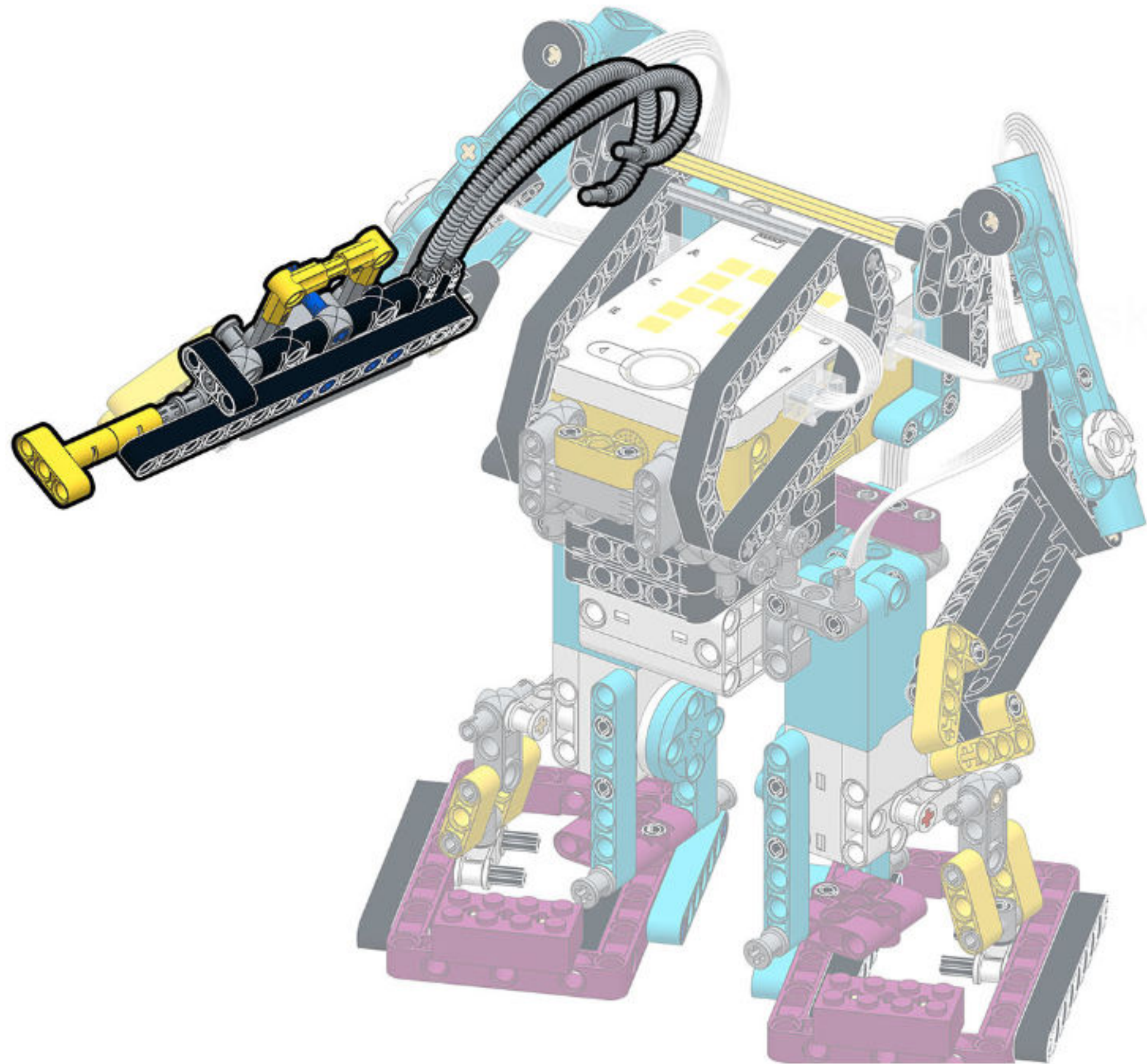

skakov@gmail.com

1/17

0

93

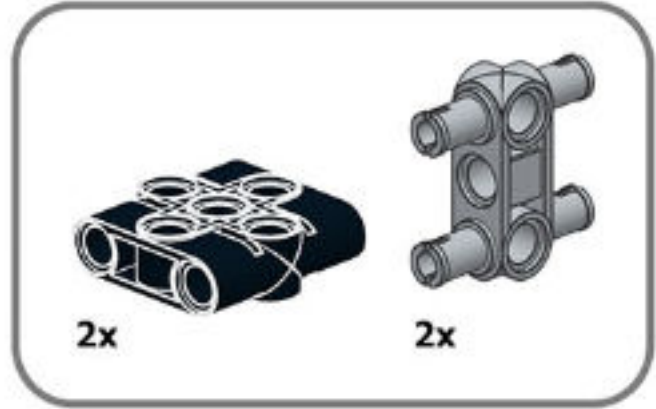

70

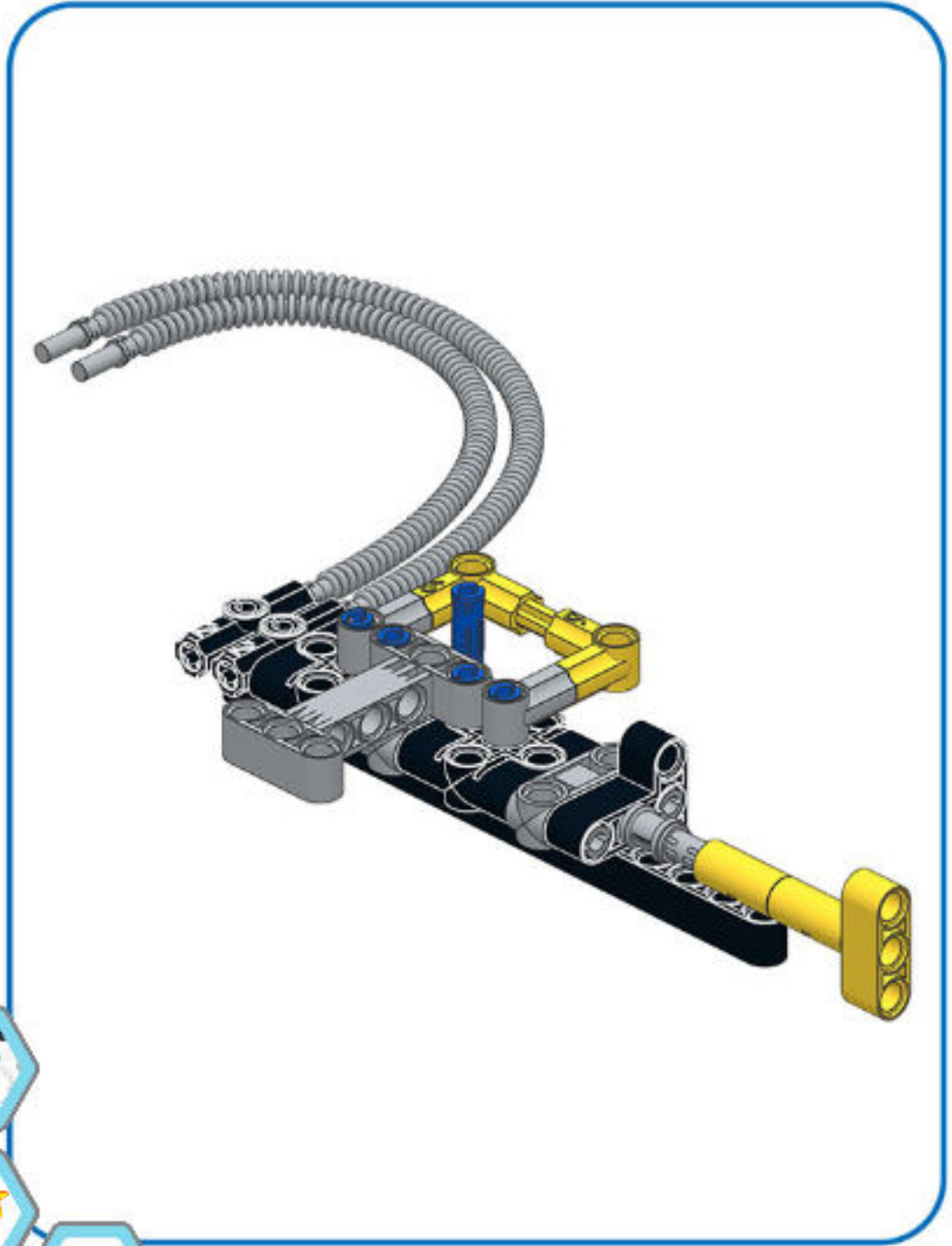
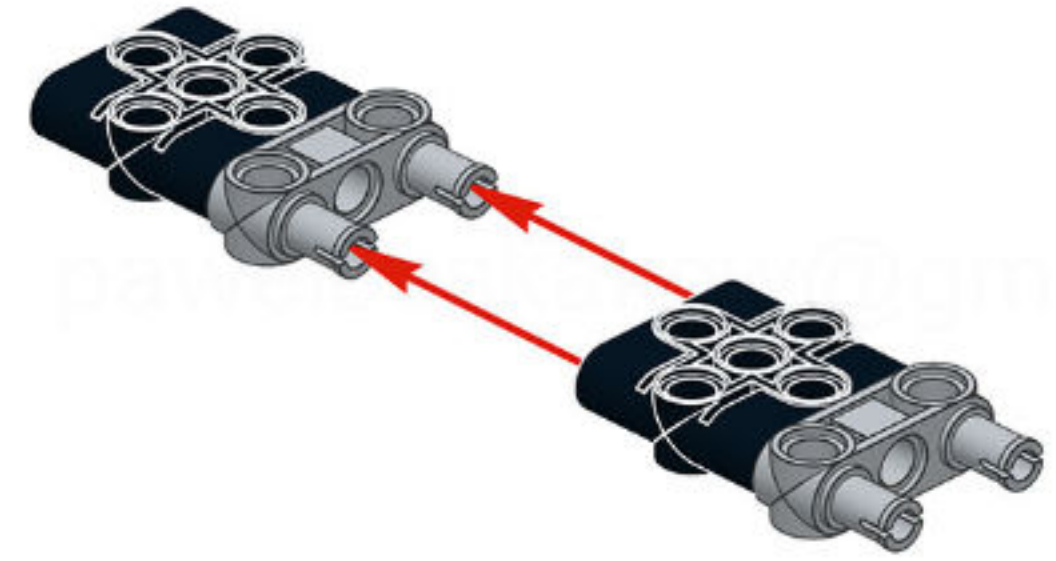

2/17

0

94

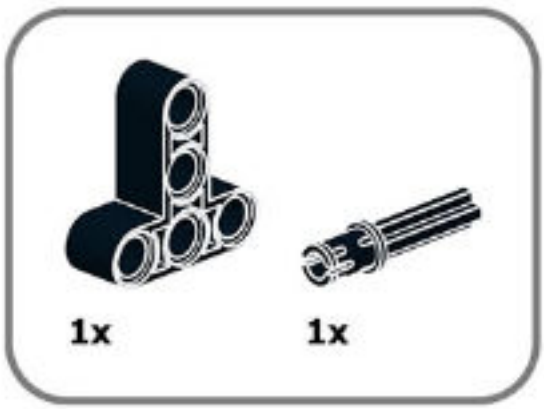

71

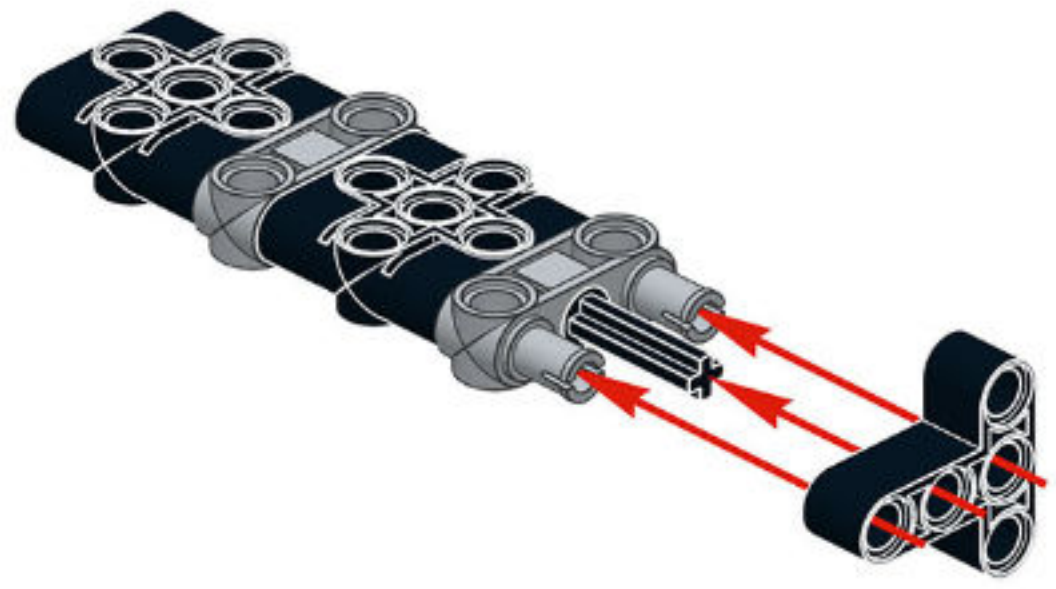

pawelbaskakow@gmail.com

3/17
0
95

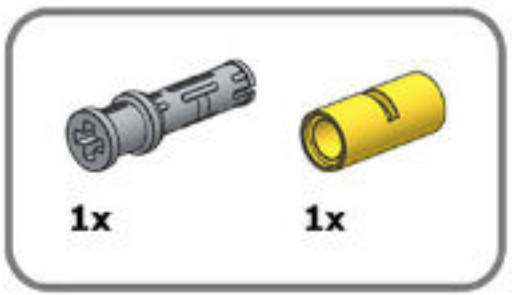

72

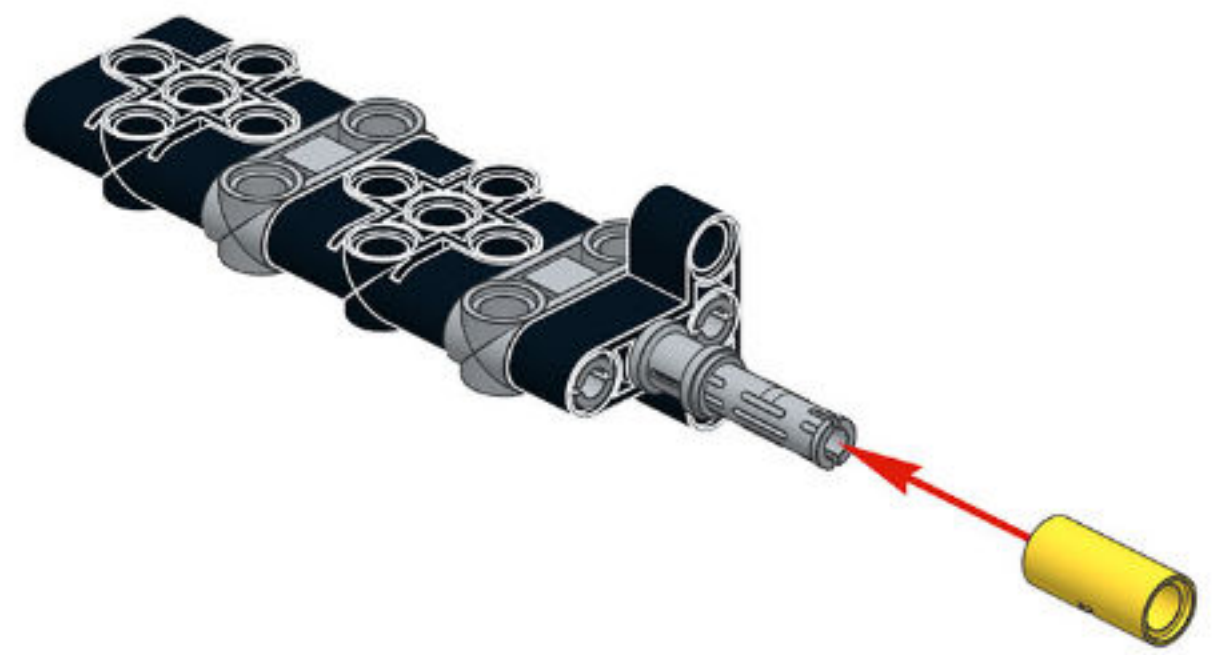

pawelbaskakow@gmail.com

4/17
0
96

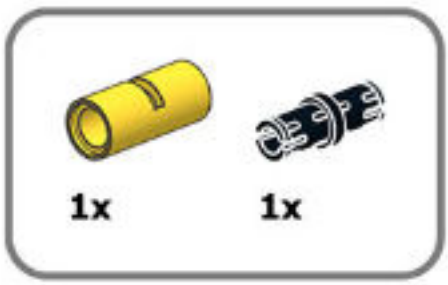

73

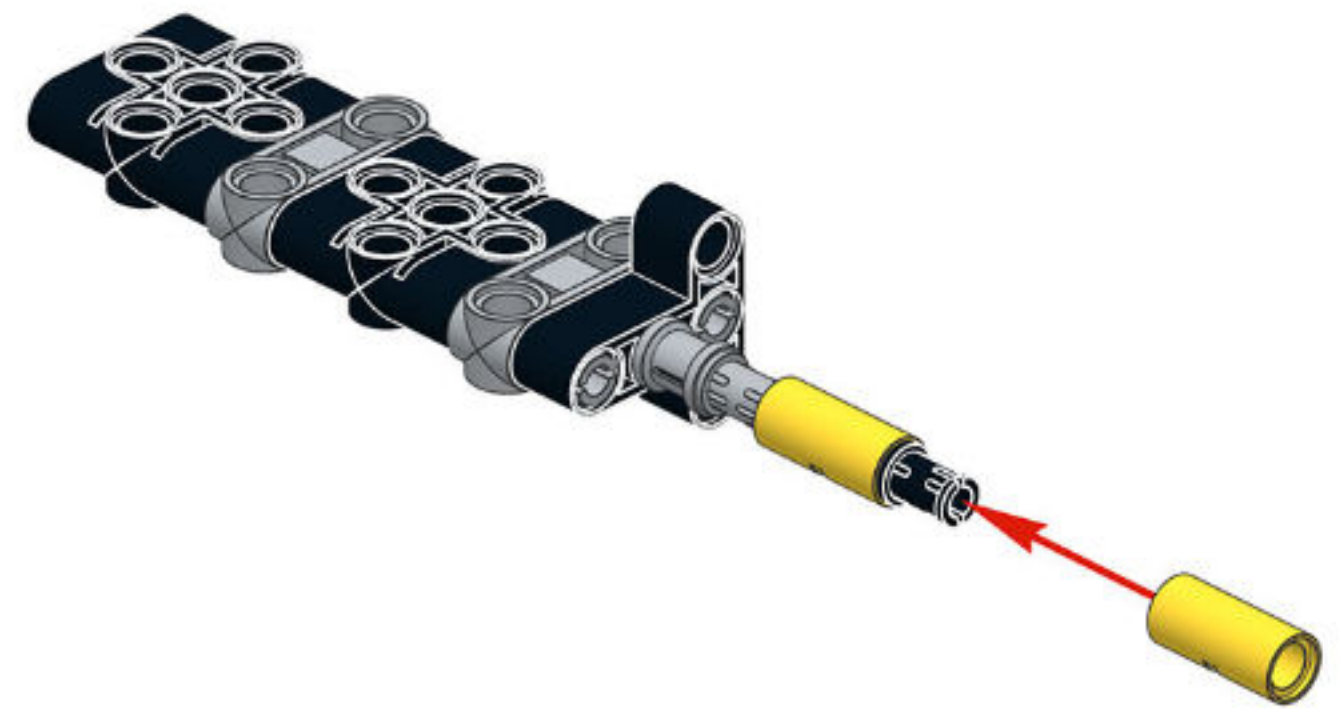

pawelbasko

5/17

0

97

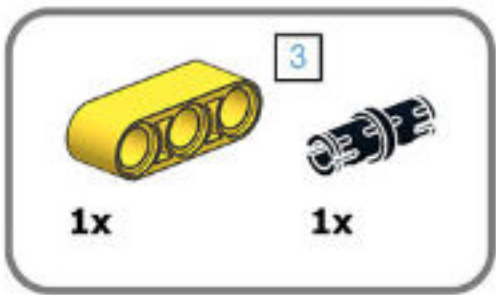

74

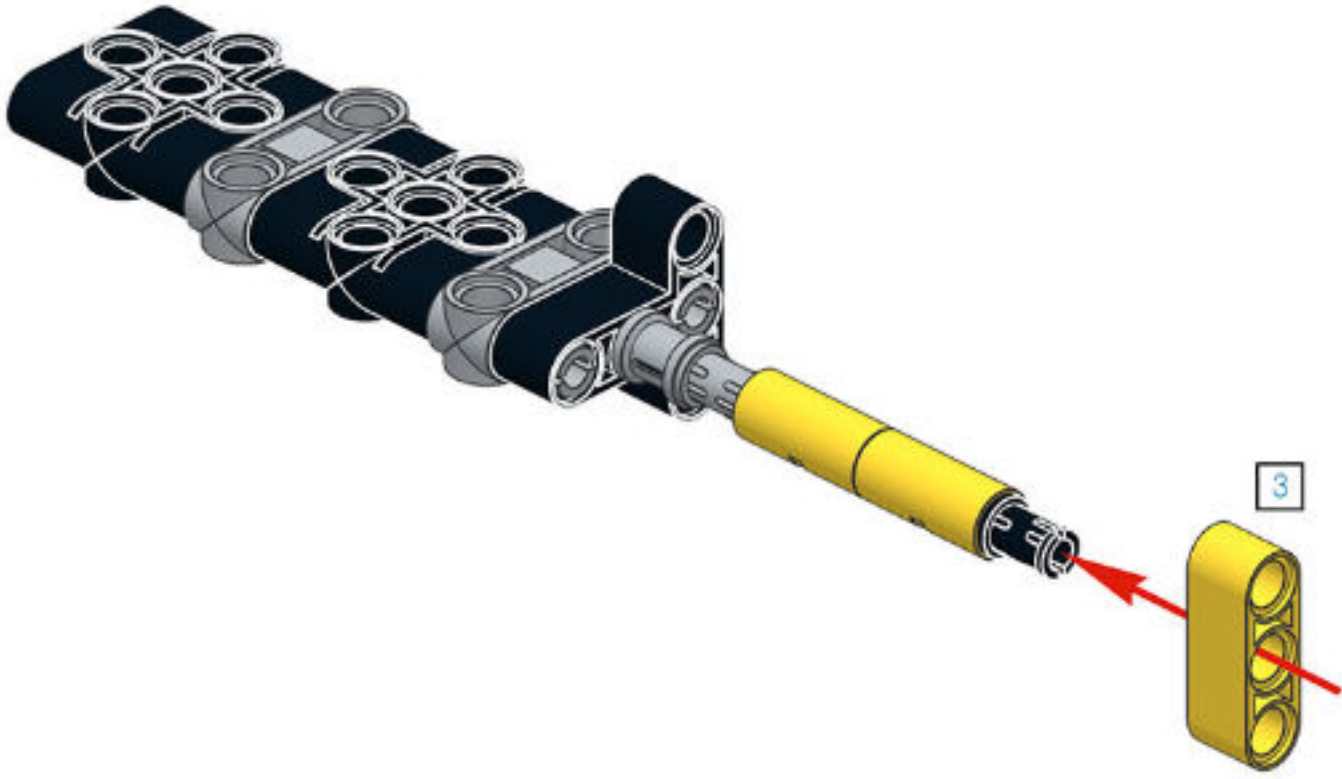

6/17
0
98

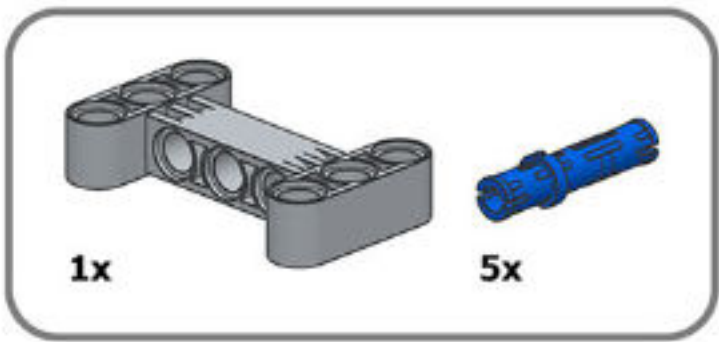

75

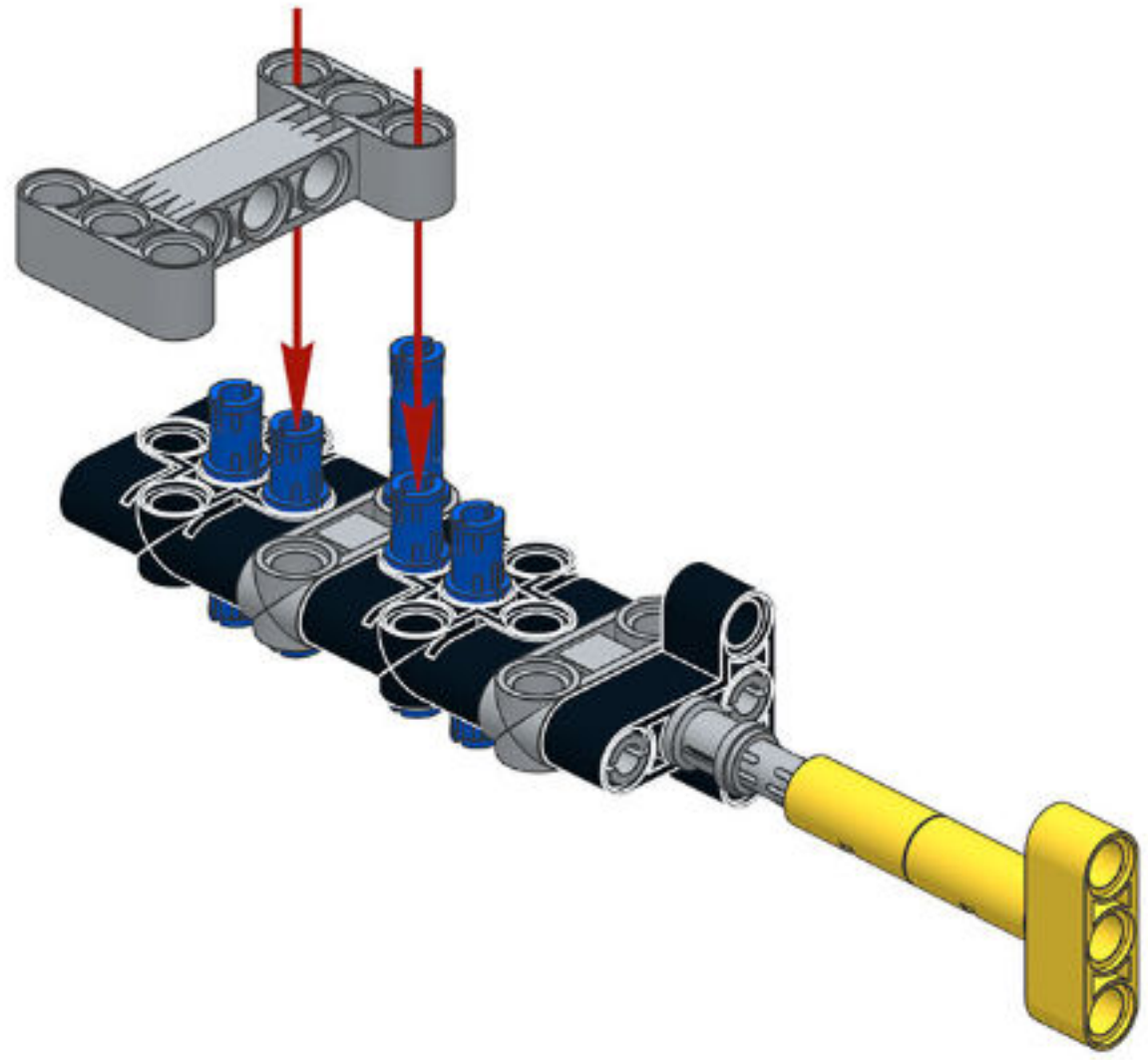

pawelbaskakov@gmail.com

7/17
0
99

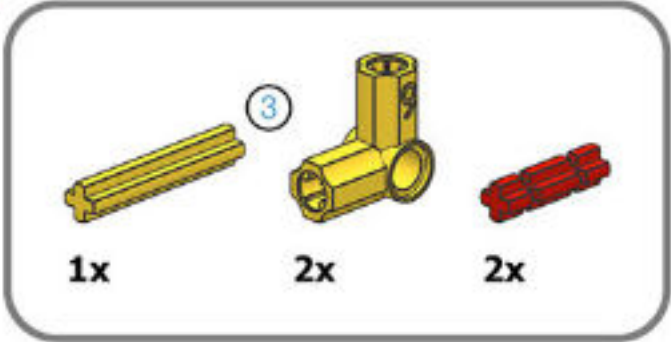

1



2

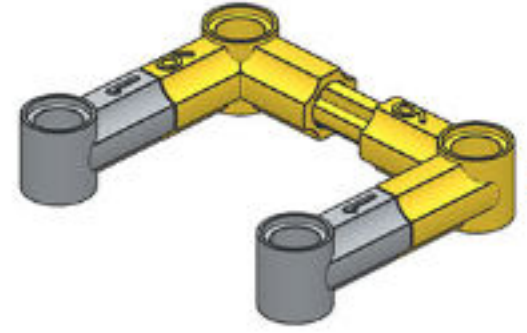
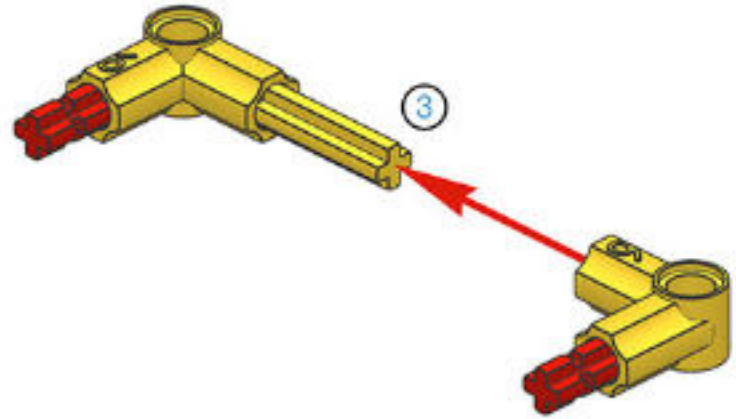

8/17

0

100

77

pavelbaskakov@gmail.com

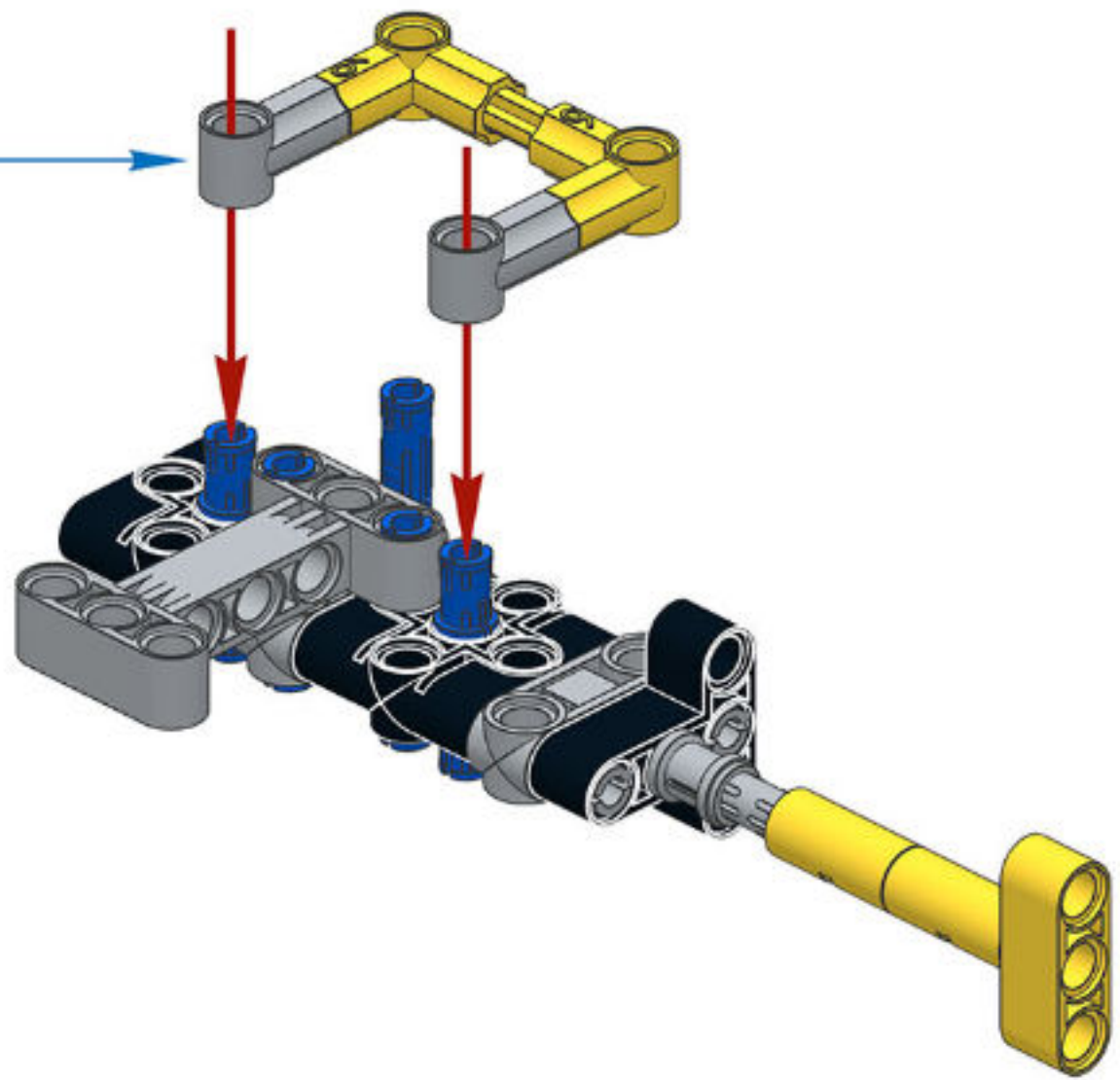

9/17

0

101

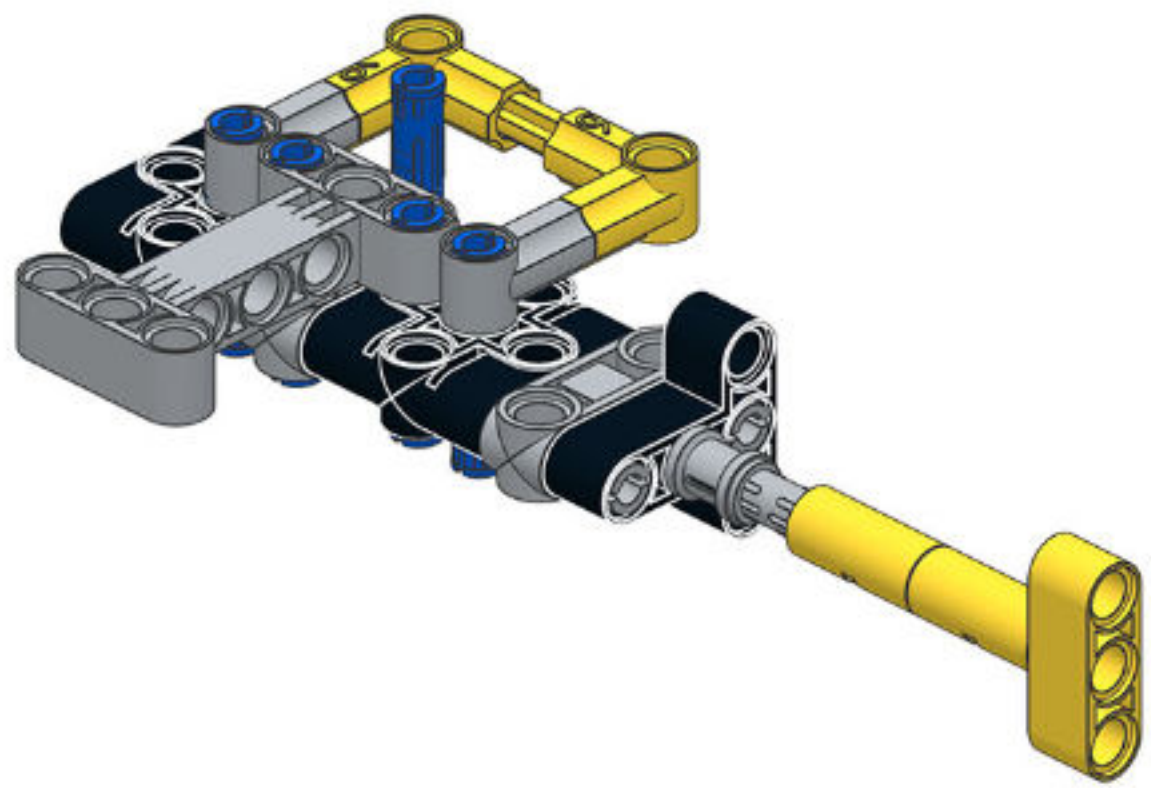

powelbask

10/17

0

102

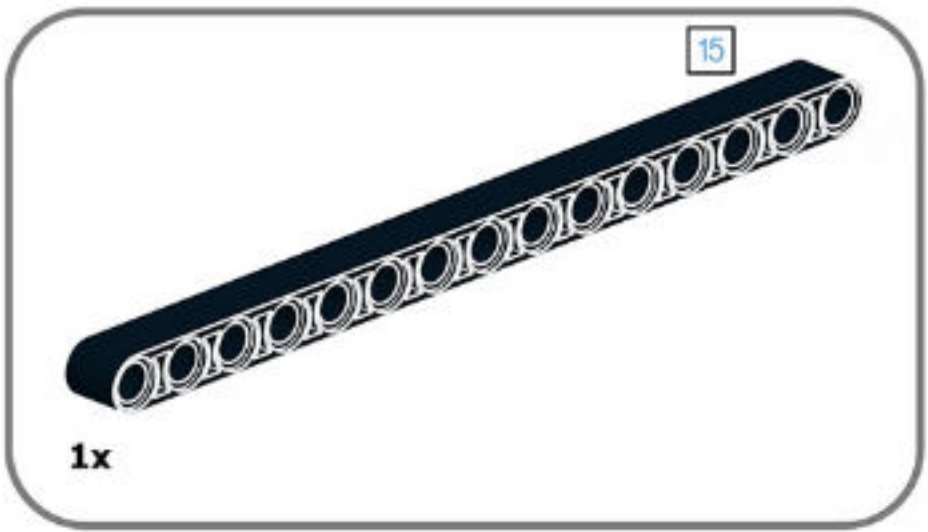

79

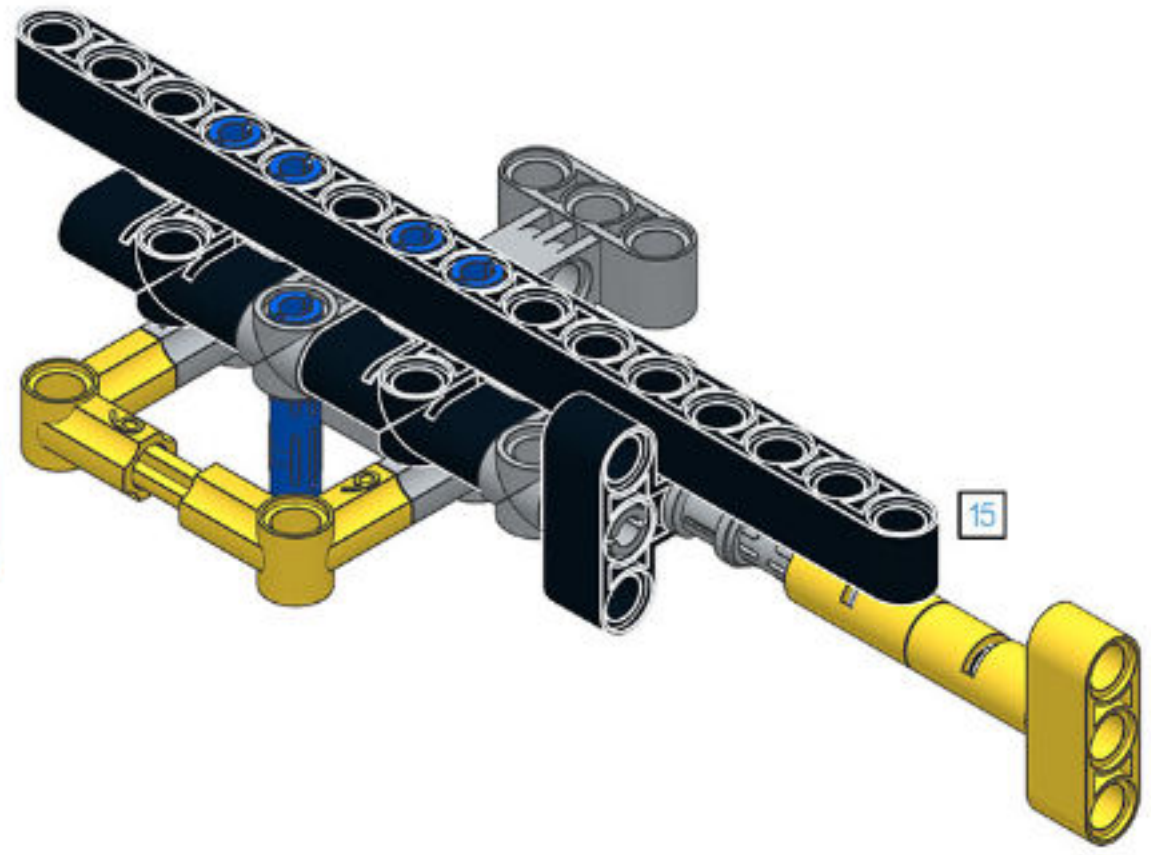

11/17

0

103

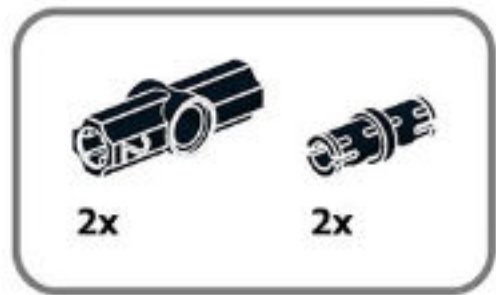

80

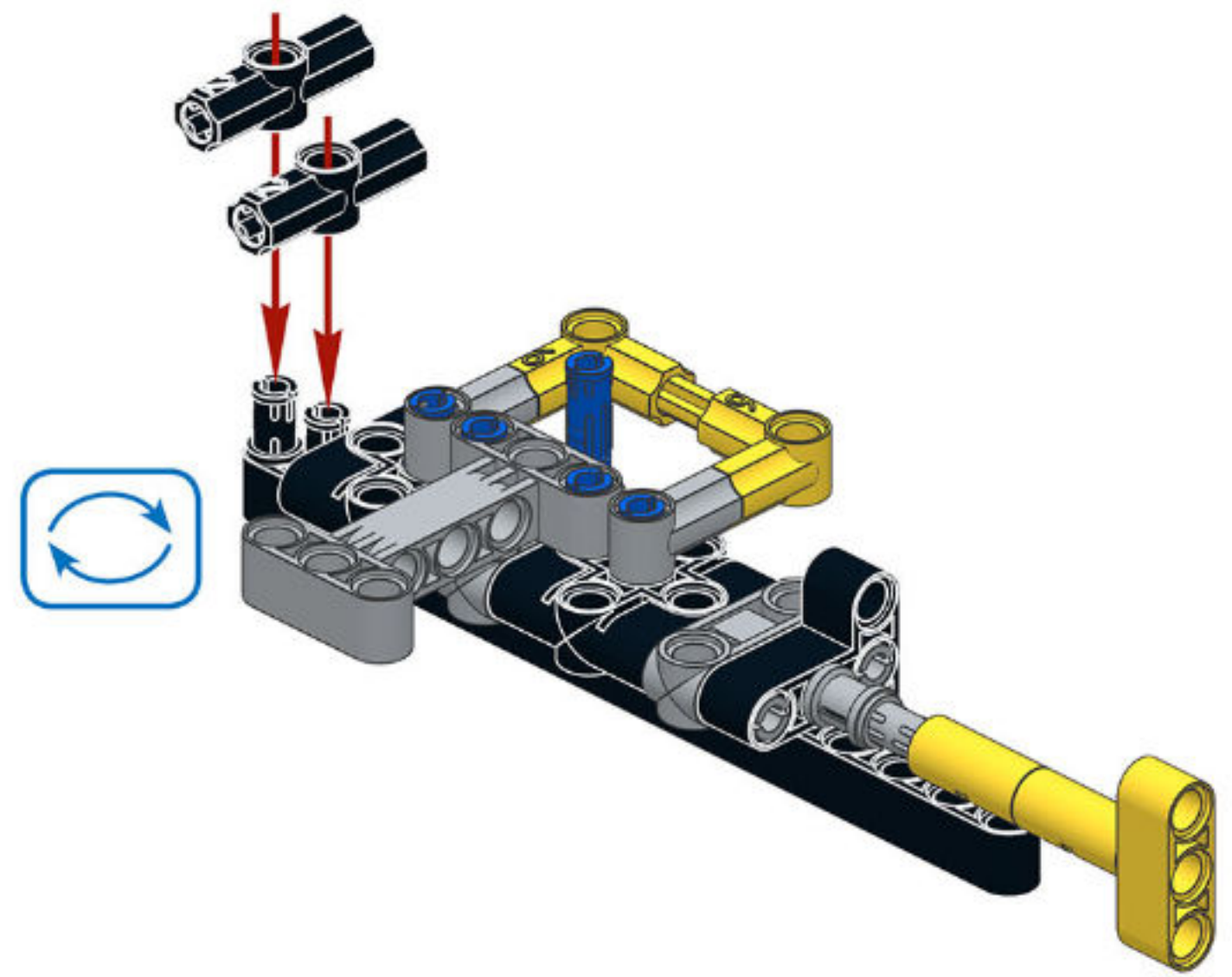

pawelbaskakow@gmail.com

12/17

0

104



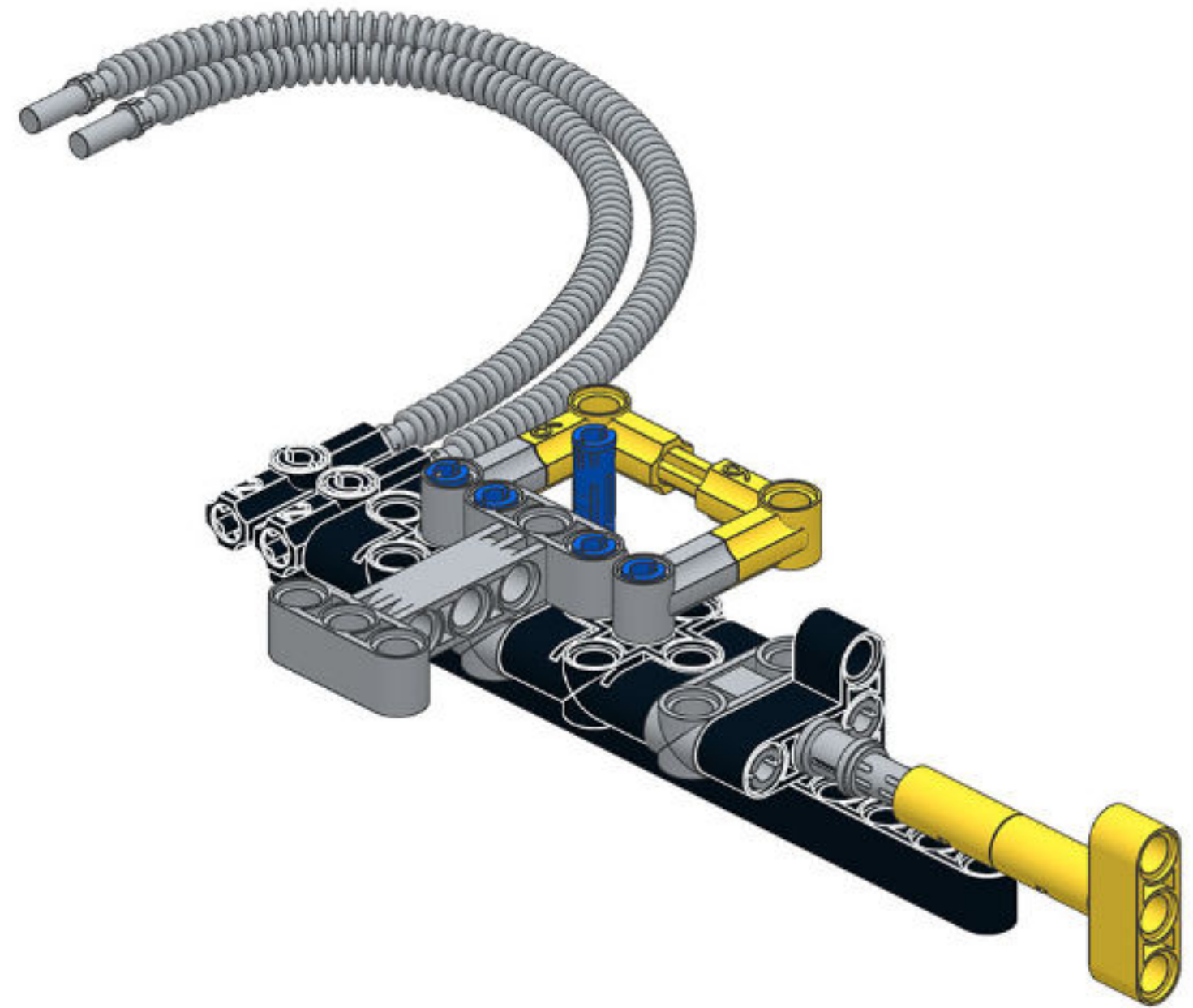

81

13/17

0

105



82



14/17

0

106

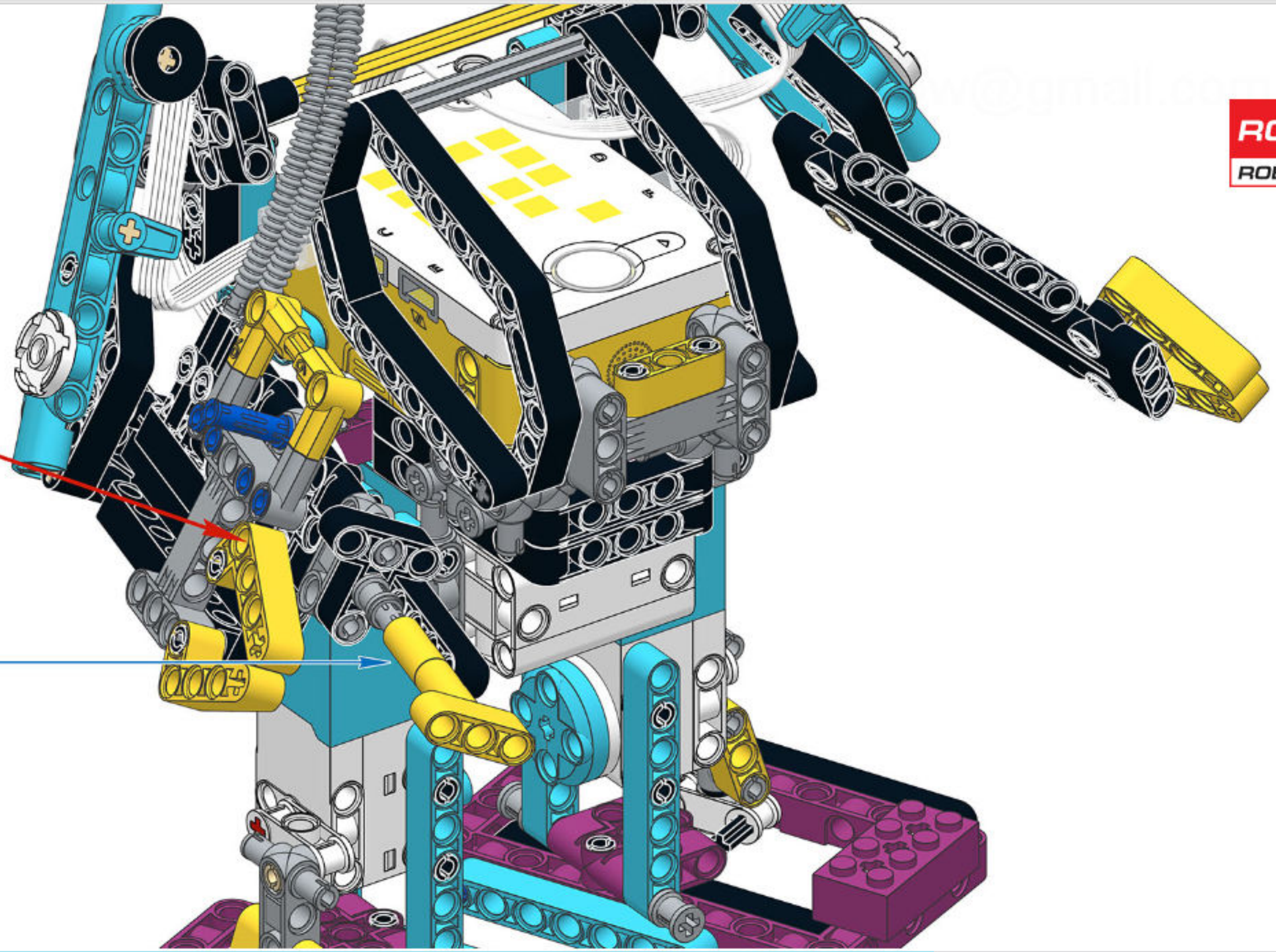

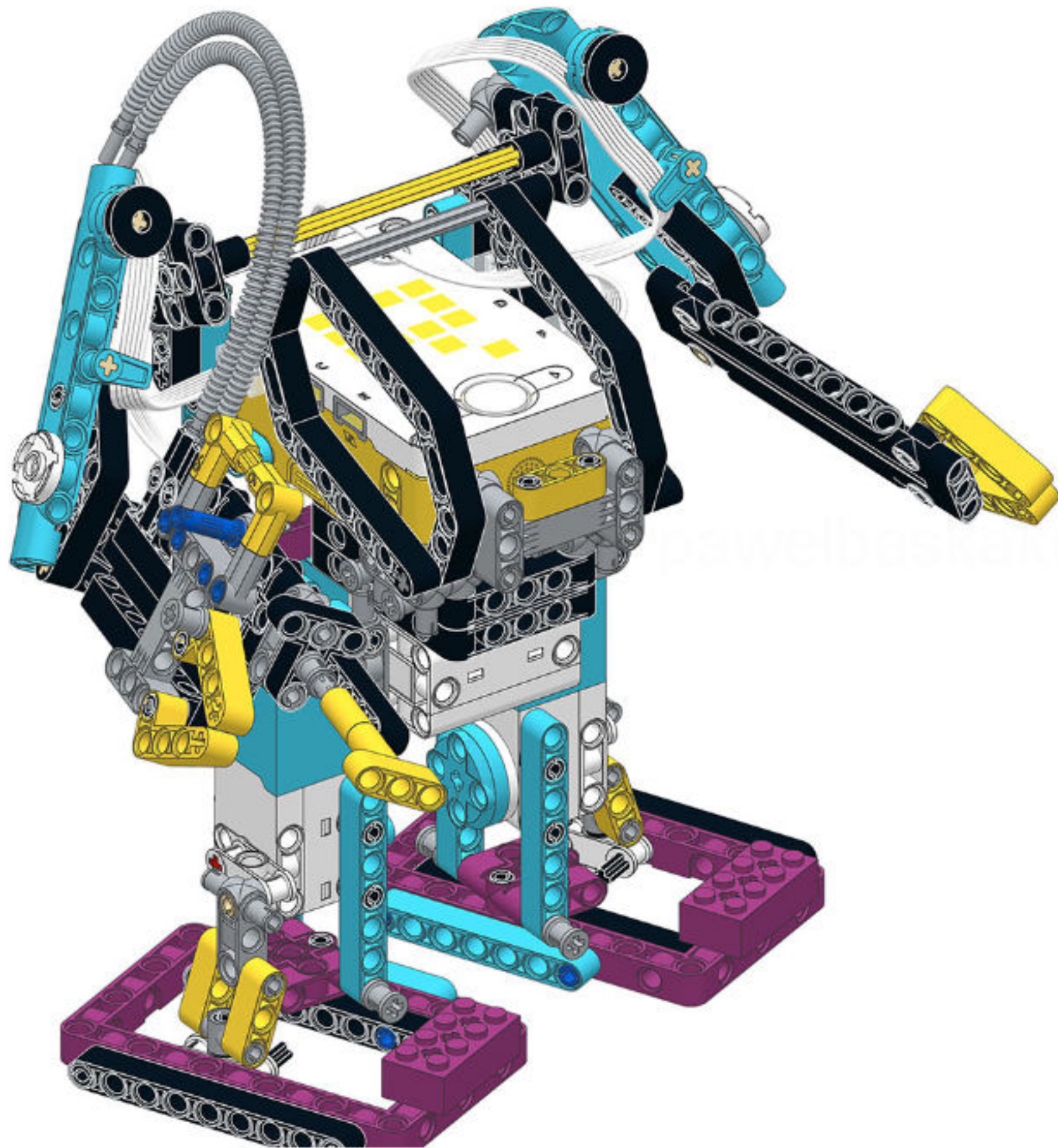

shesheov@gmail.com

15/17

0

107

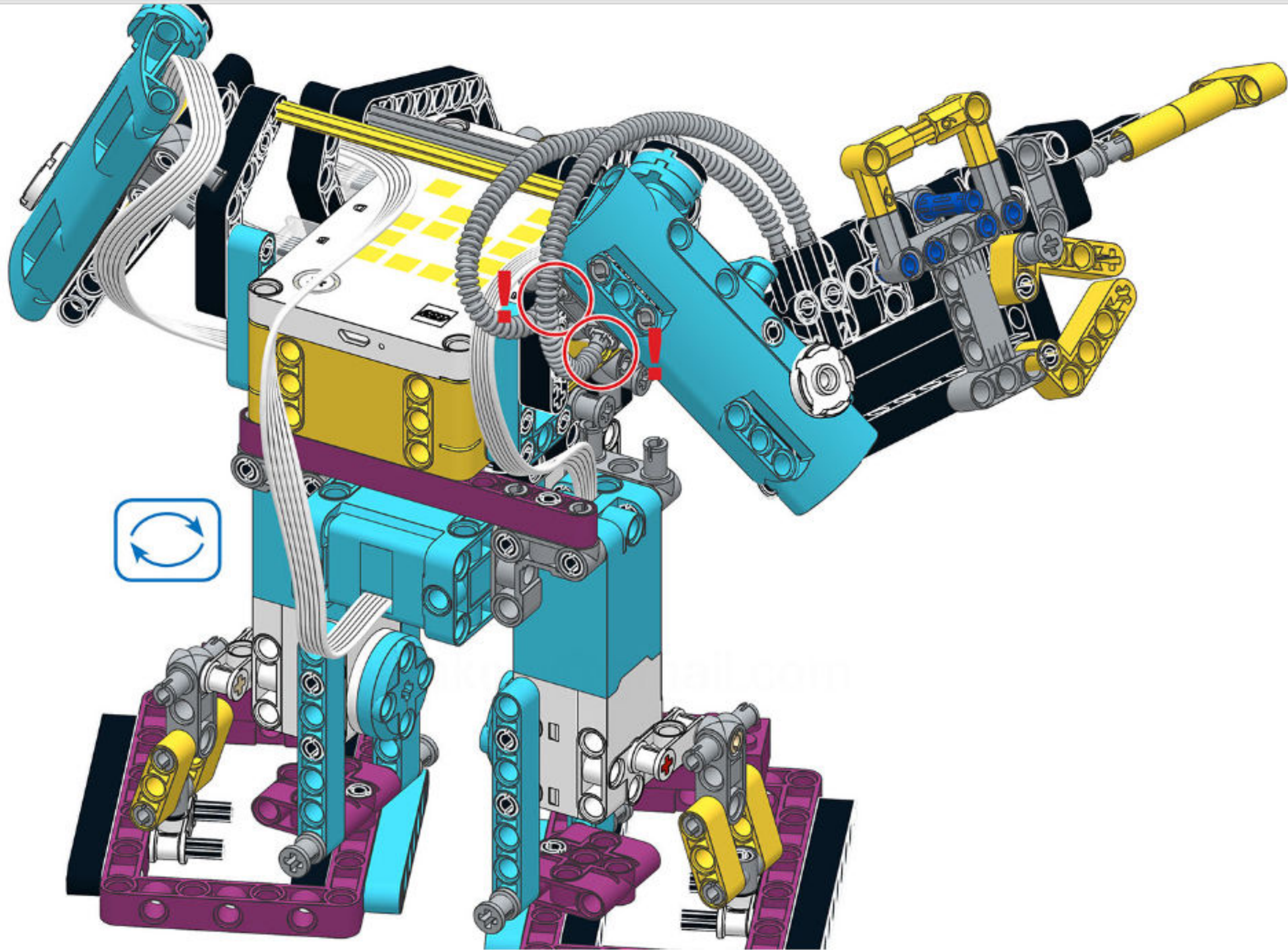

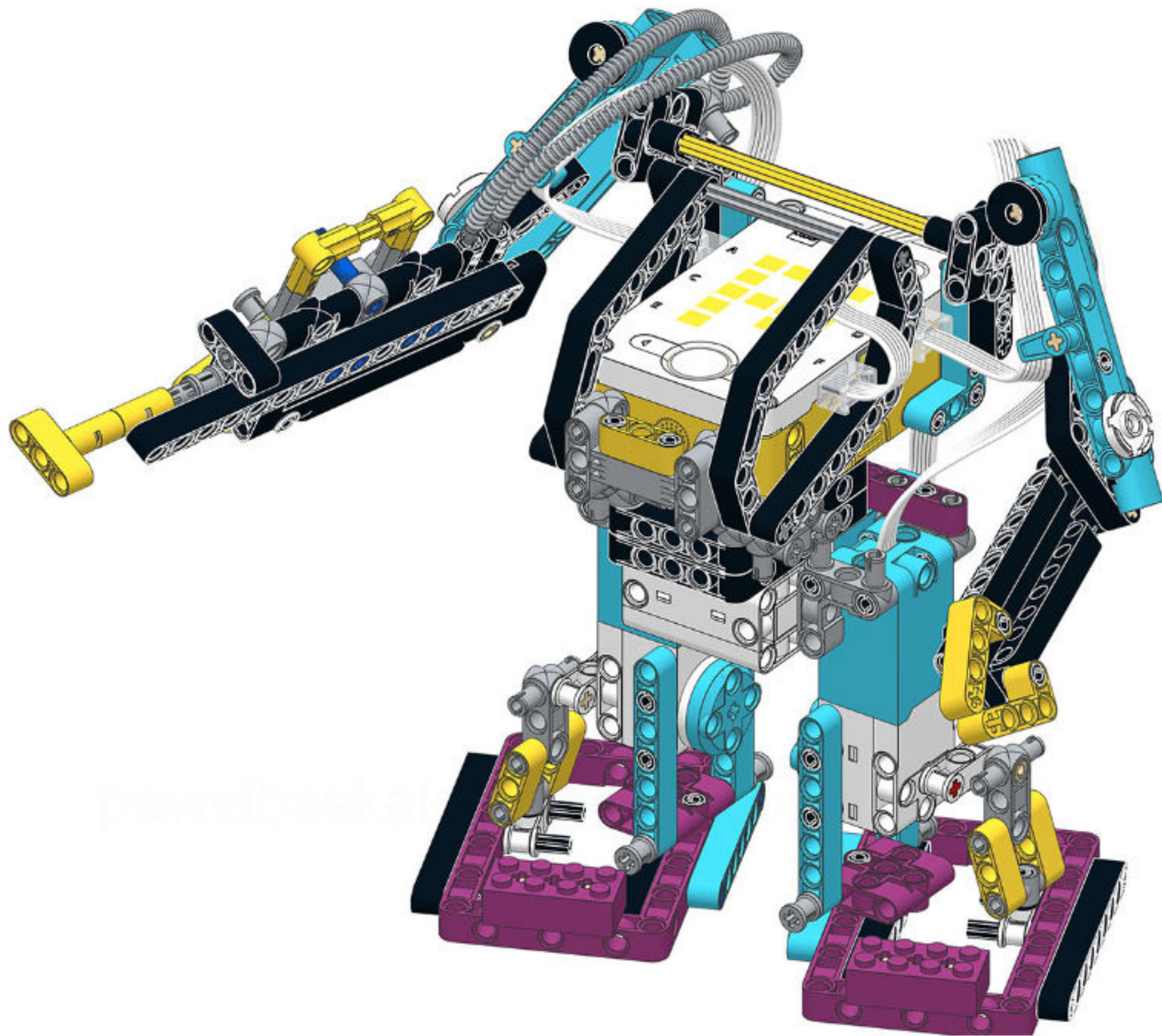

power basket

17/17

0

109





Task 1. Program

Algorithm

Program

The algorithm for setting the legs to the starting position can be as follows:

- 1 Set motor rotation speeds
- 2 Set motors to position '0'



Task 2. Program

Algorithm

Program

The program might look like this:

```
when program starts
Init
  set movement speed to 10 %
  set movement motors to A+B
Left
```

```
define Left
  move ↓ for 90 degrees
  repeat 2
    move ↶ for 180 degrees
    move ↑ for 180 degrees
  move ↓ for 90 degrees
```

ROB
ROBO

pawelbaskako



Task 3. Program

Algorithm

Program

The program might look like this:

```
when program starts
  Init
  set movement speed to 10 %
  set movement motors to A+B
  Right

define Right
  move ↑ for 90 degrees
  repeat 2
    move ↻ for 180 degrees
    move ↑ for 180 degrees
  move ↑ for 90 degrees
```

ROB
ROBO

PLAY



Task 4



Write a program to study the phases of a robot's motion. Movement phases are the walking phases that make up the robot's movement. Your robot takes two steps and returns to its original position. In this case, four stages (phases) of movement can be distinguished. Watch how the robot steps.





Task 4. Program

Algorithm

Program

The program should work according to the following algorithm:

1 Set the initial position of the legs and set the motors for movement

2 Walk 90 degrees, display '1' and wait 3 seconds

3 Walk 90 degrees, display "2" and wait 3 seconds

4 Walk 90 degrees, display '3' and wait 3 seconds

5 Walk 90 degrees, display '4' and wait 3 seconds

To repeat



Task

Place the images of the motion phases in the correct order.



1

2

3

4





Task 5



Program the movement of the robot's torso. The torso should move in sync with the walking. This will ensure that the torso is always "forward". This can be achieved either by programming the synchronous movements of the servo motor, or using gyroscope data.

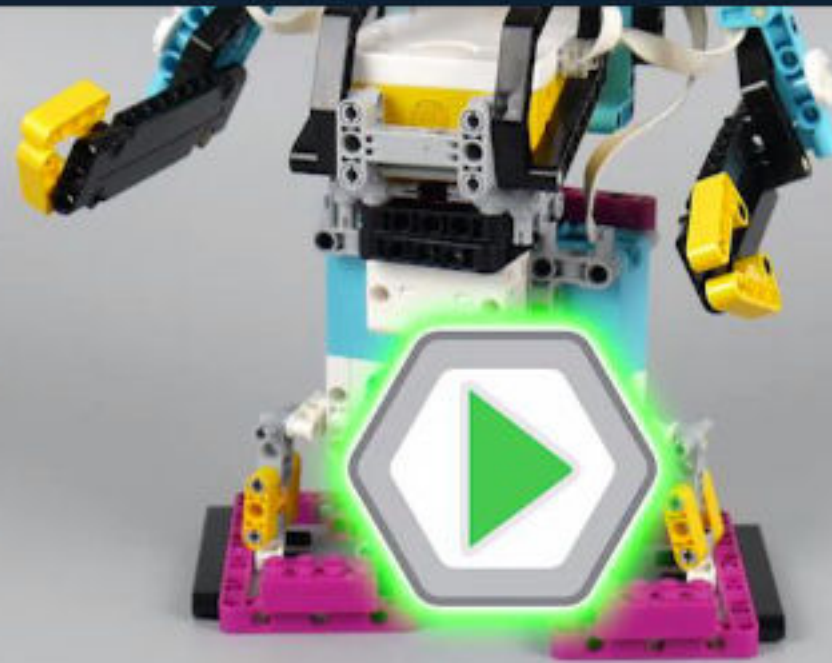



Task 5. Program

Algorithm

Program

Let's first program the synchronous movements of the servo, and then use the gyroscope and compare the results. To accomplish the task, the program can work according to the following algorithm:

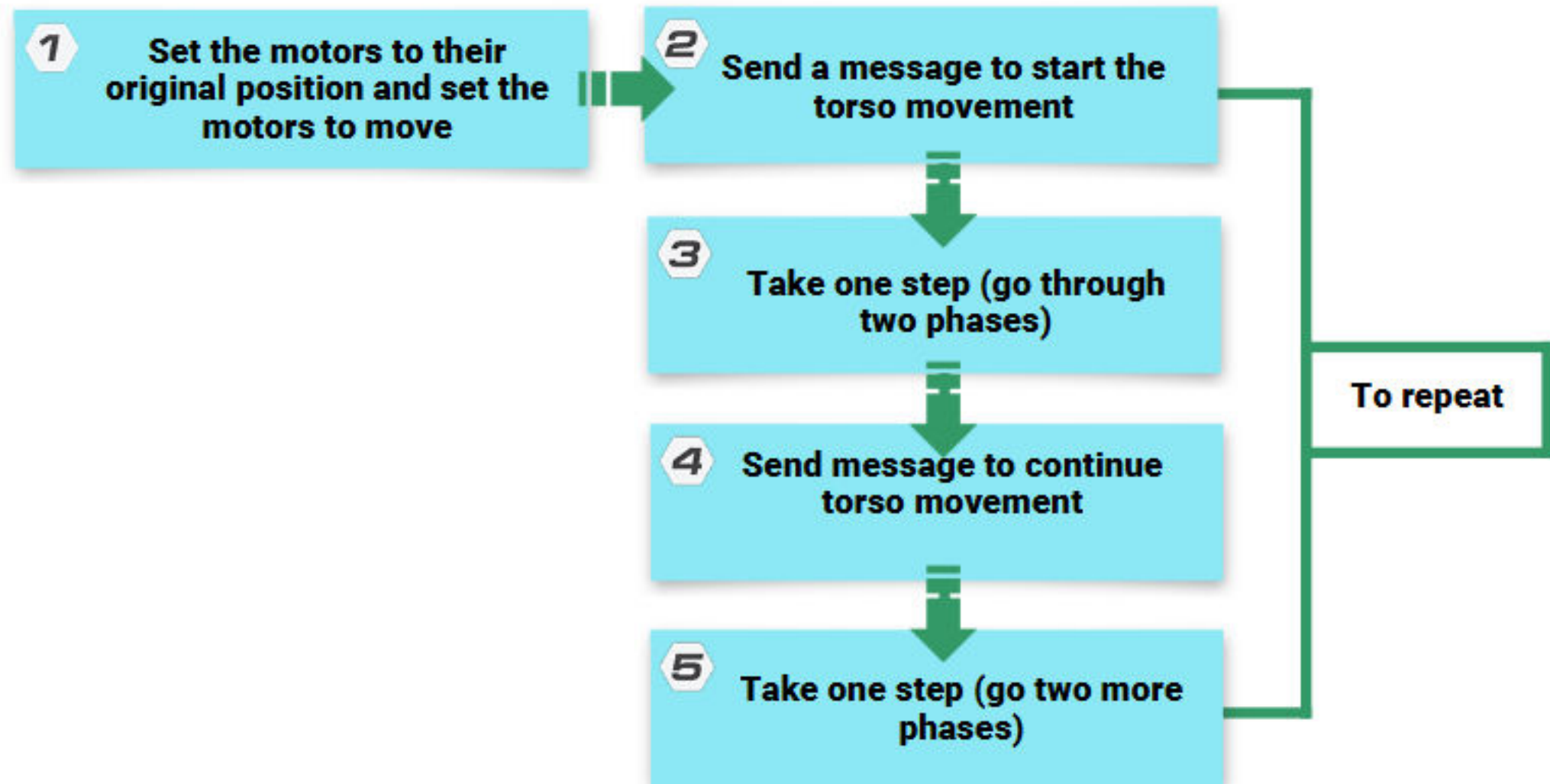



Task 6 *



You may have noticed that the robot does not walk evenly due to the fact that we synchronize the movements of the torso and legs between steps. All movements can be made continuous by calculating the desired torso angle from the current position of the leg motor. Try this idea and test the robot

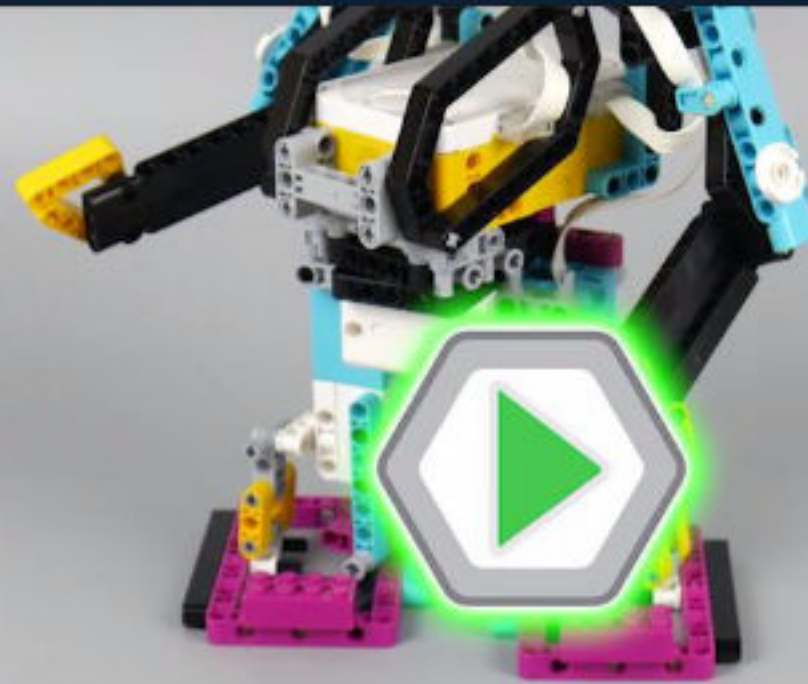

0



123



Task 6 *. Program

Algorithm

Program

The rotation algorithm is as follows:

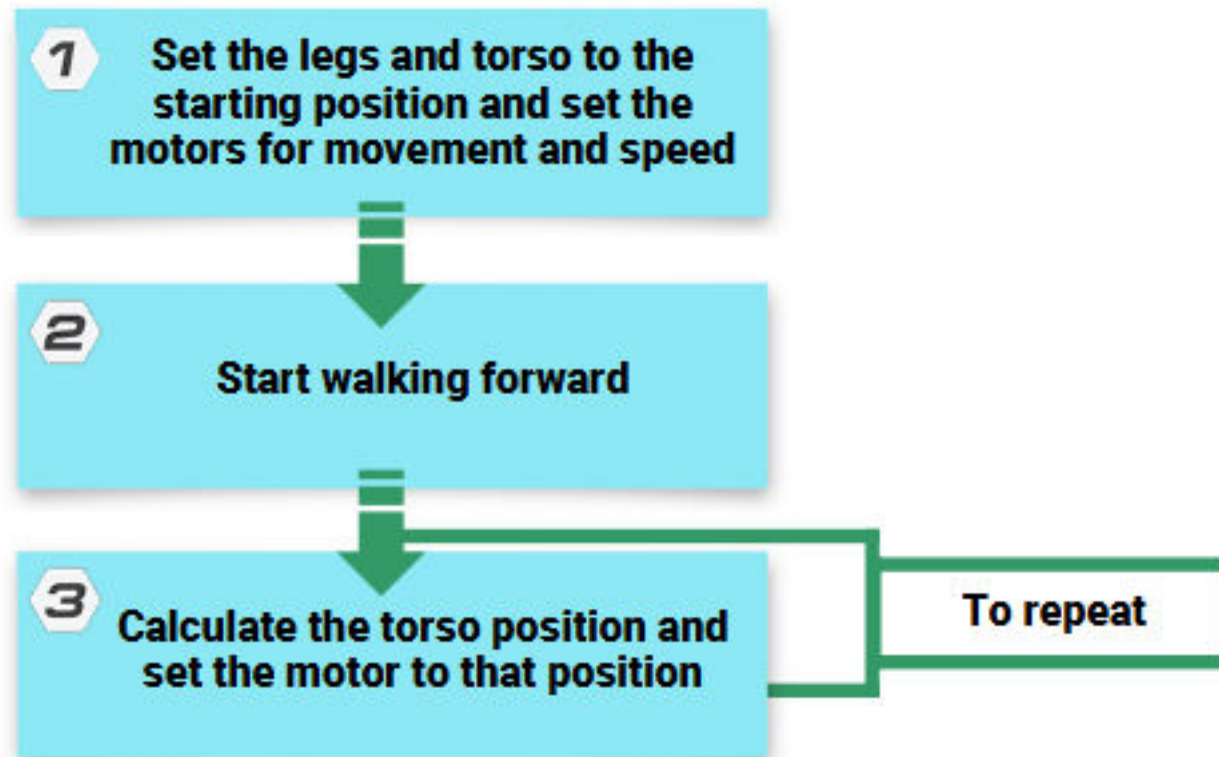



Task 7



Program to maintain torso direction using gyroscope data. This will make it possible to maintain direction even when the robot is not walking.

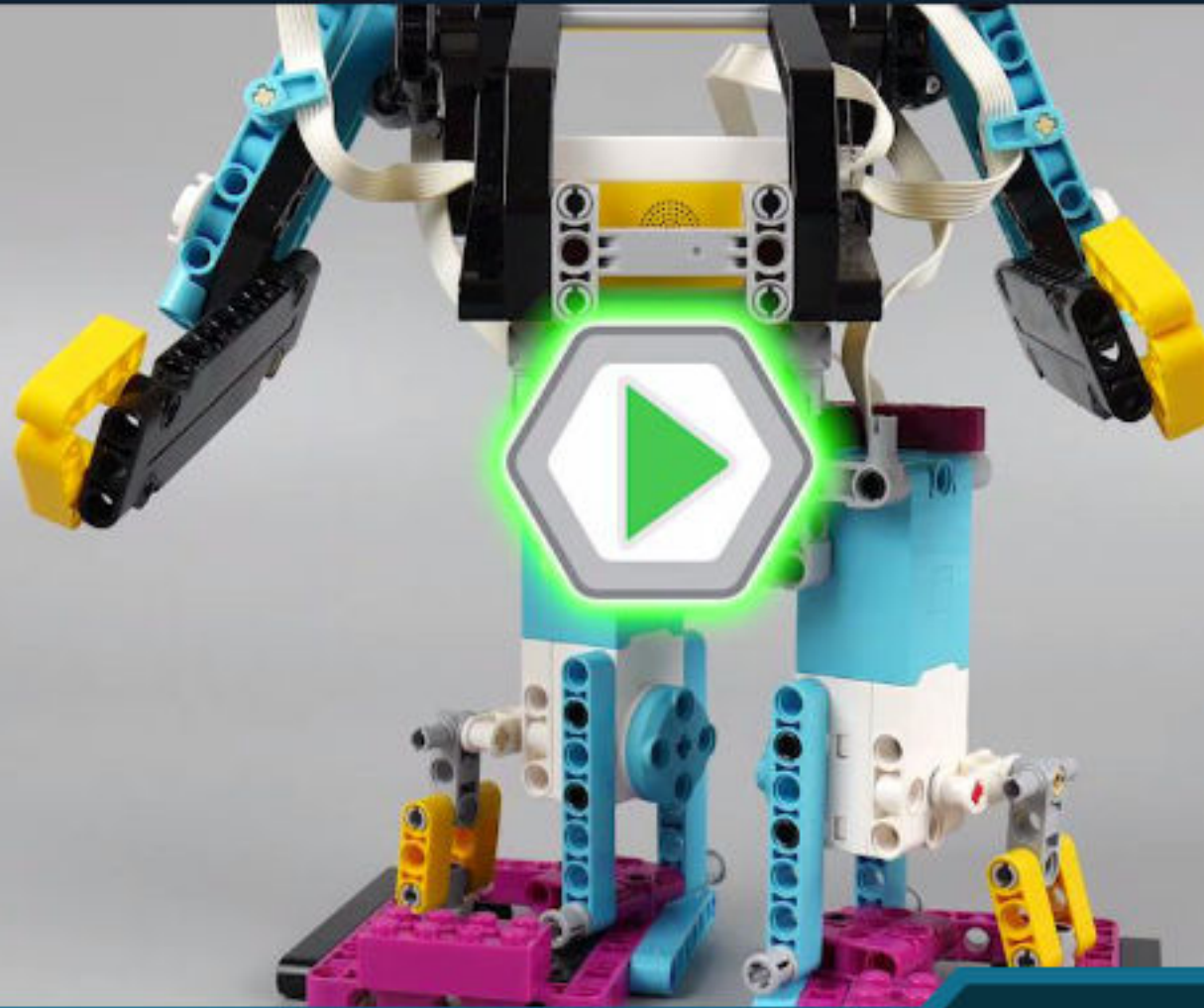



Task 7. Program

Algorithm

Program

The program should work according to the following algorithm:

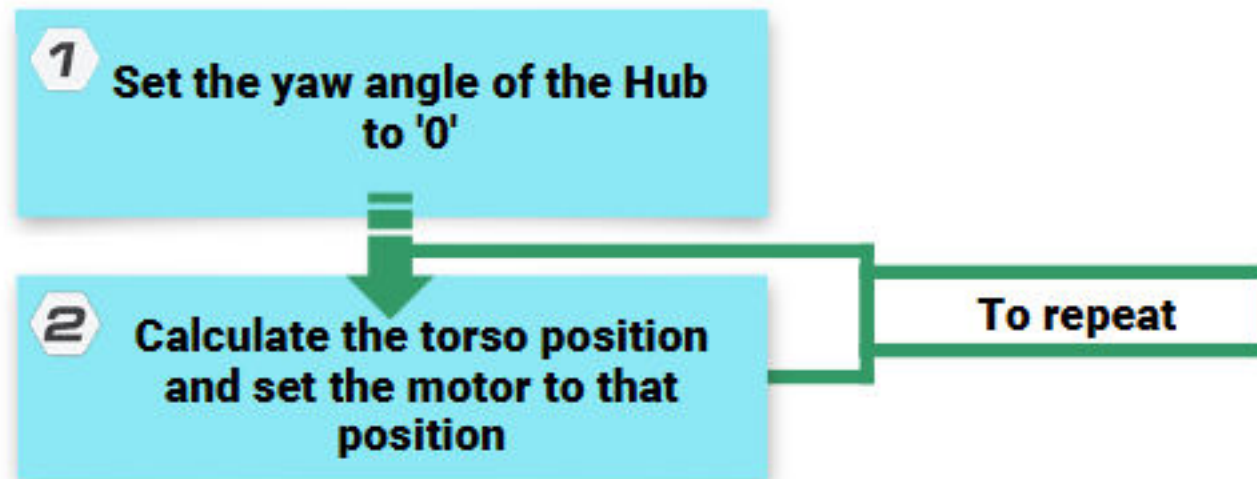



Task 8



Program the robot to move forward while maintaining the direction of the torso using gyroscope data.

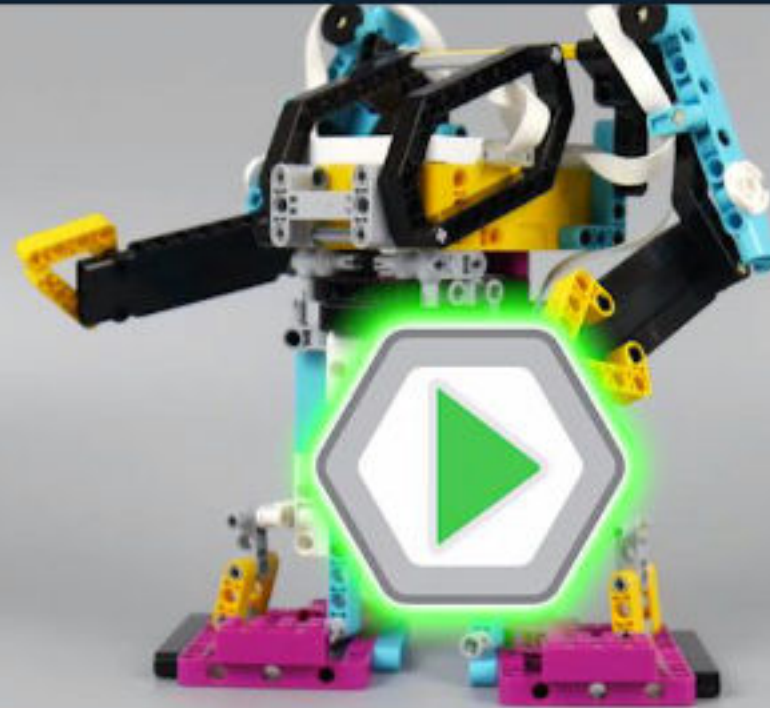

0



127



Task 8. Program

Algorithm

Program

A program may look like this:

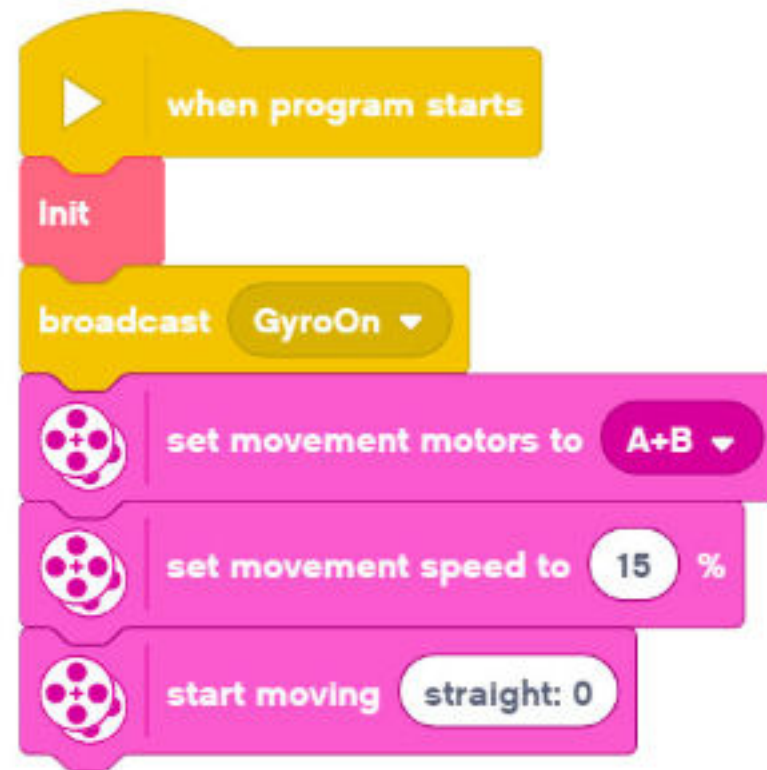

ROB
ROBO

pavel@askarovy.com

Decorative icons in the bottom left corner, including a yellow star with the number 0, a red and yellow play button, and a hexagon with the number 128.



Task 9



Program the robot to stop if it falls. For fall detection, it is convenient to use the Hub orientation data. If its front part is not directed upwards, most likely the robot has fallen and must be stopped.

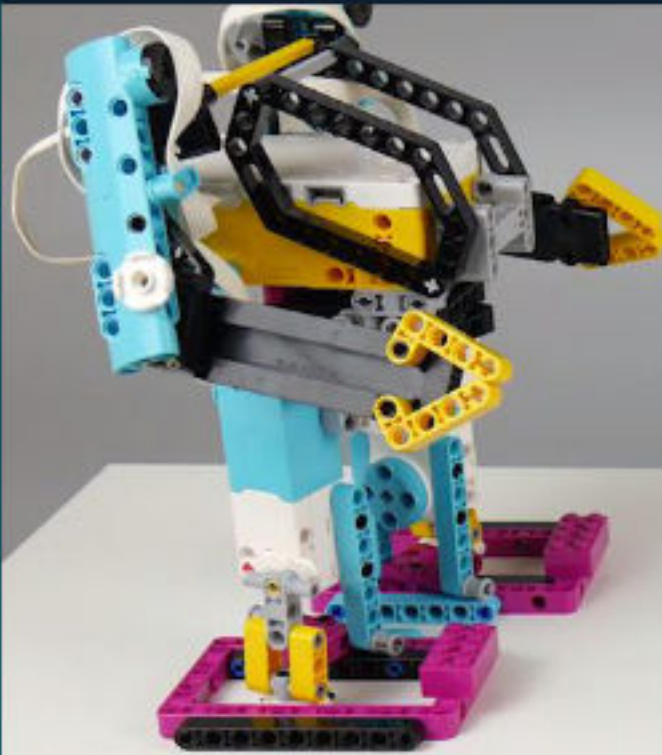



Task 9. Program

Algorithm

Program

The program should work according to the following algorithm:

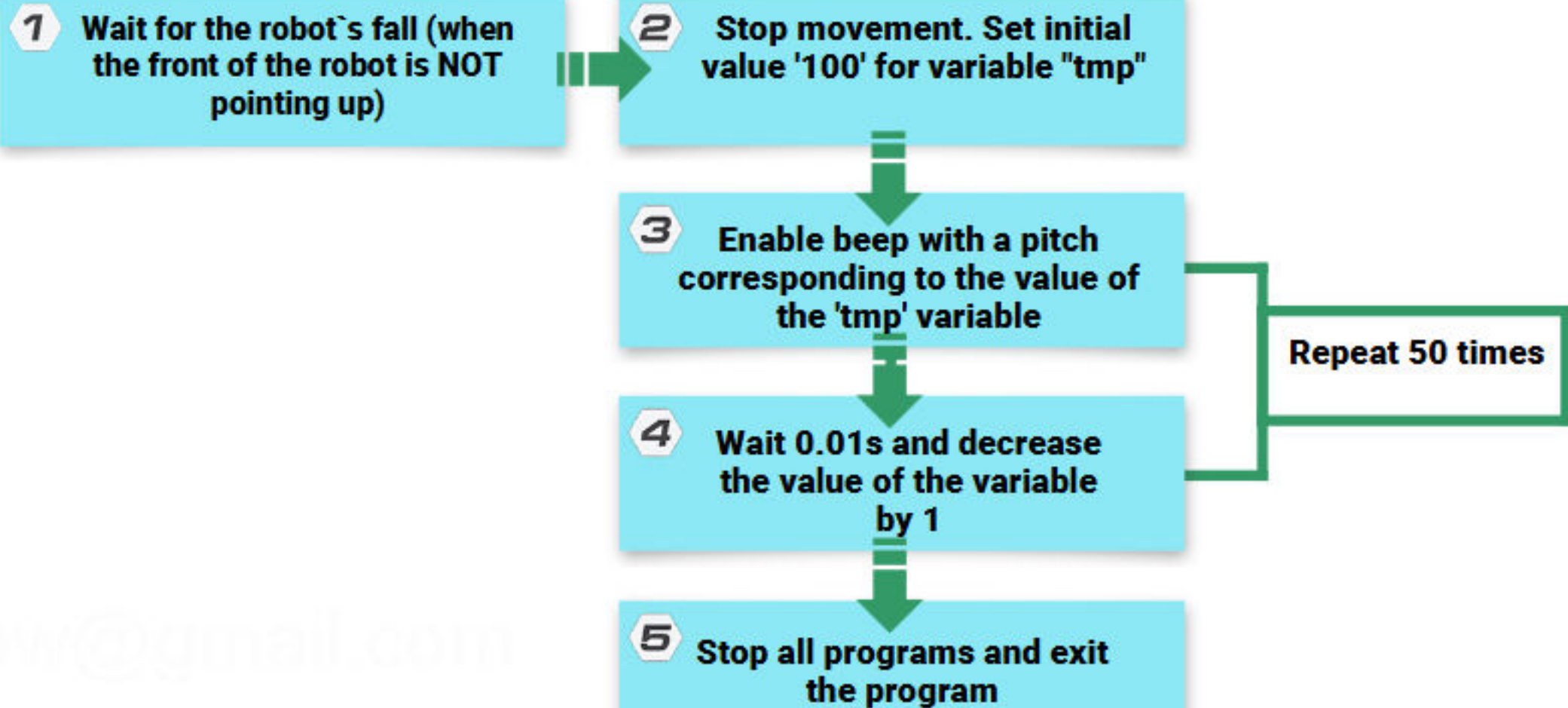



Task 10



An Ultrasonic Distance Sensor can be used to detect obstacles in front of the robot. Figure out how to attach it to the robot.

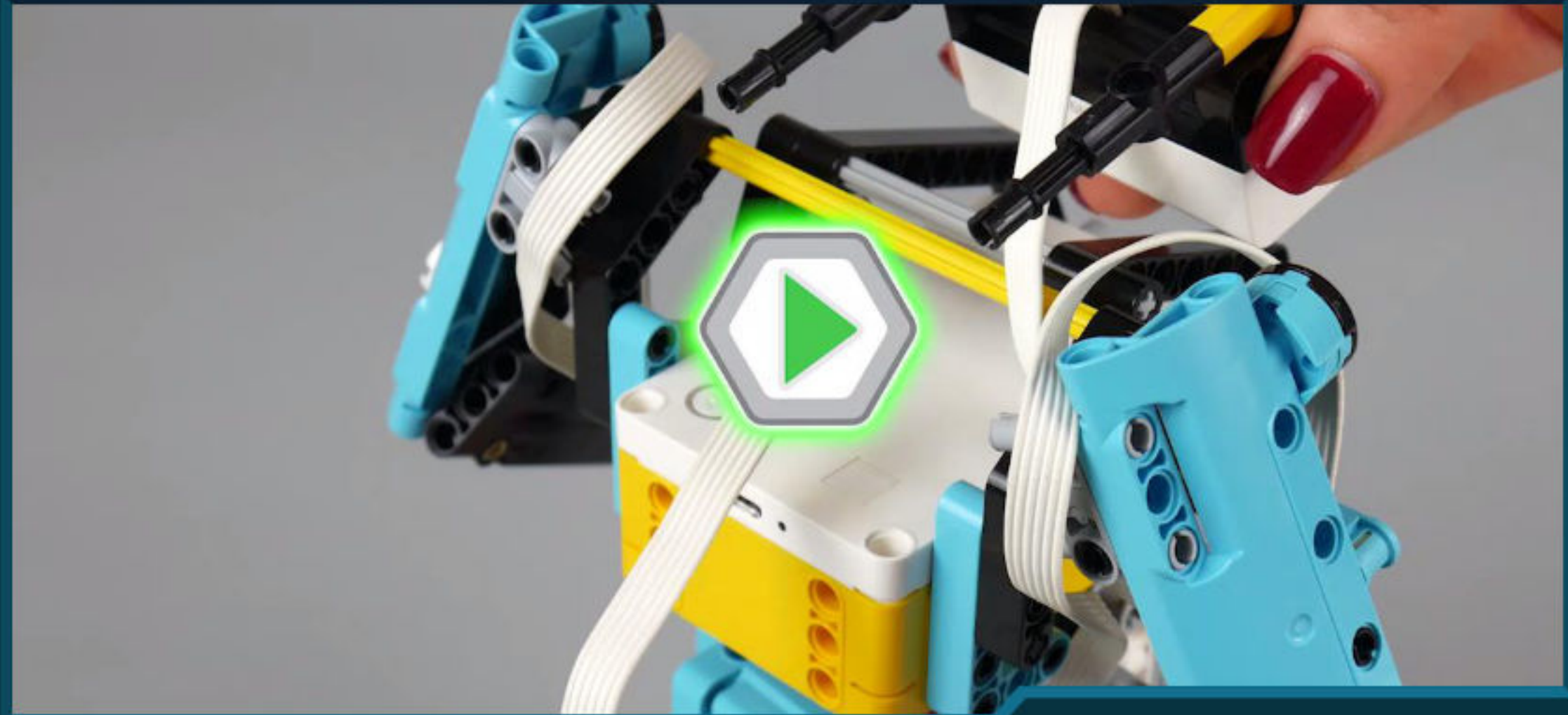



Task 11



Program obstacle avoidance. Please note that during the rotation, you must stop the program supporting the direction of the robot's torso.

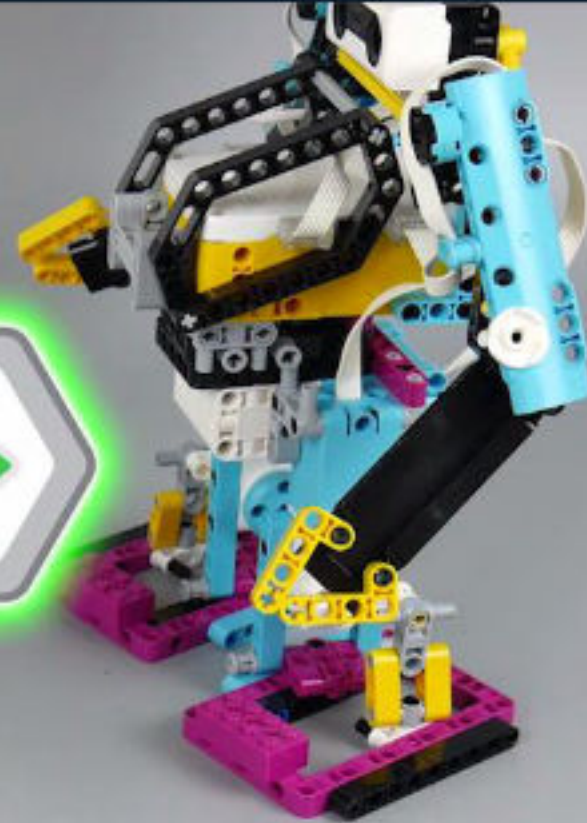



Task 11. Program

Algorithm

Program

The program should work according to the following algorithm:

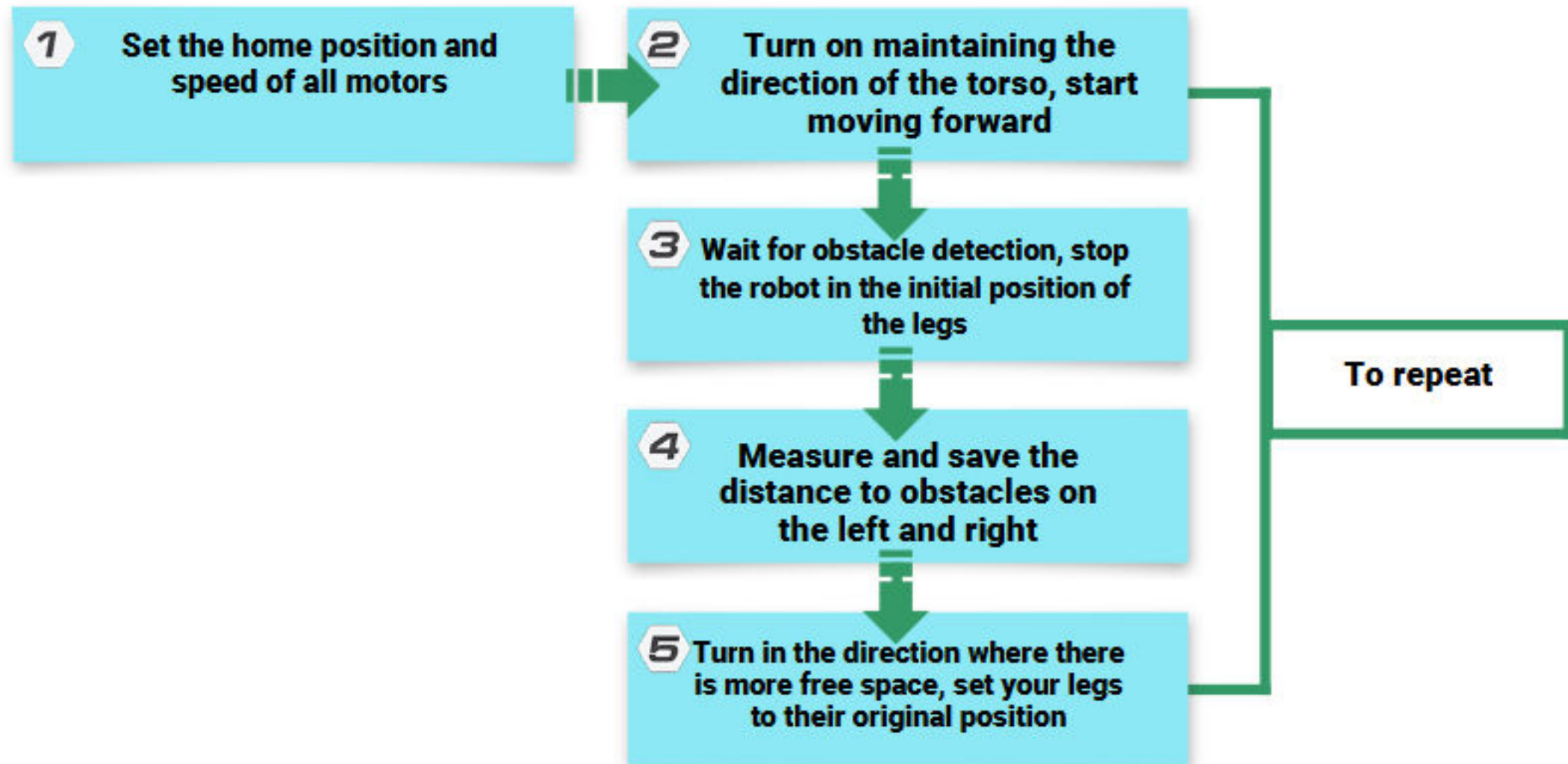



Task 12 *



Program the forward movement to maintain the direction of the torso and track the direction of travel. When moving the robot to the left or right, it must turn in the opposite direction to maintain the initial direction of movement.





Task 12 *. Program

Algorithm

Program

The program should work according to the following algorithm:

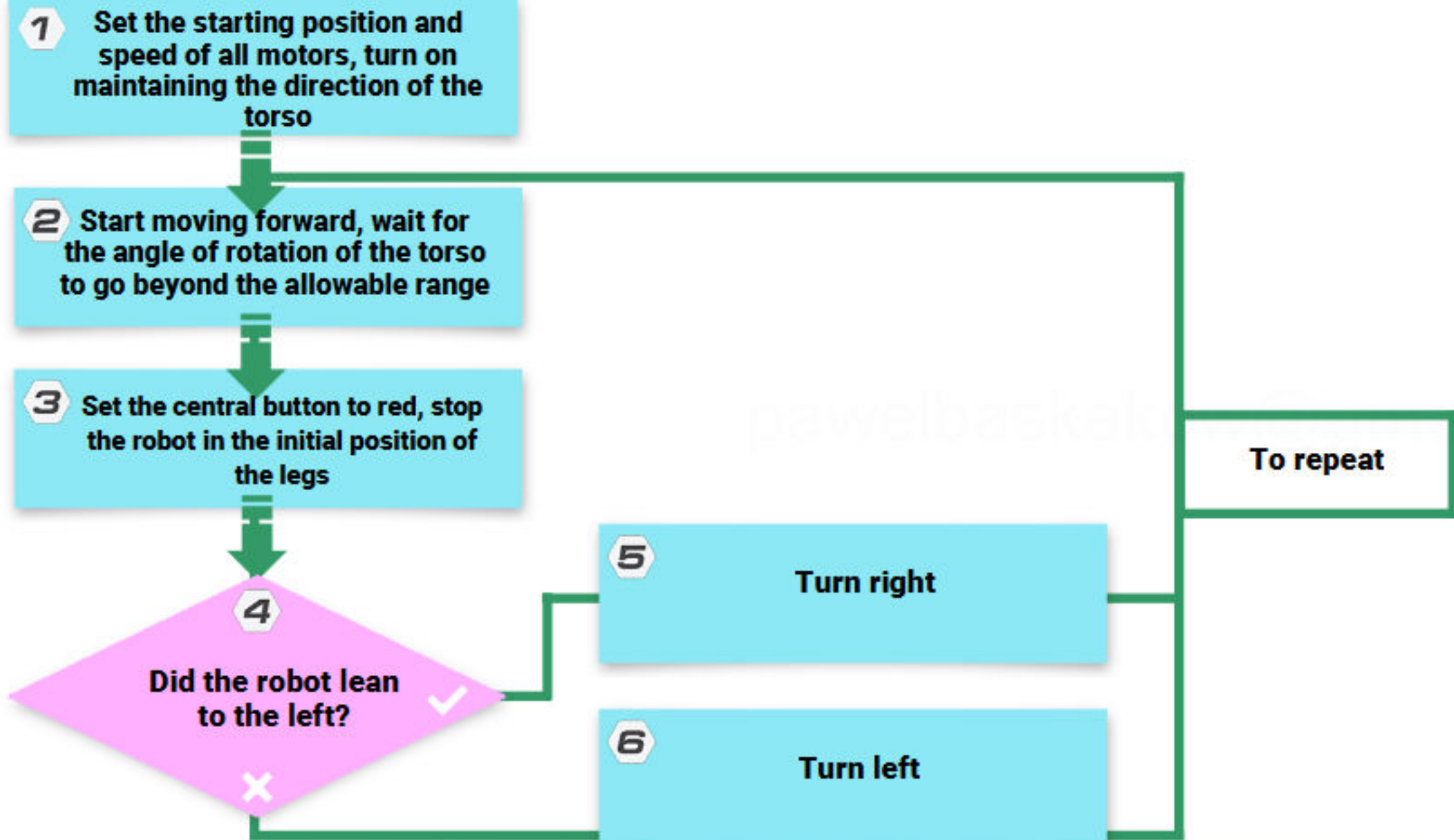



Question

Which of the robot elements shown below is responsible for turning the torso?

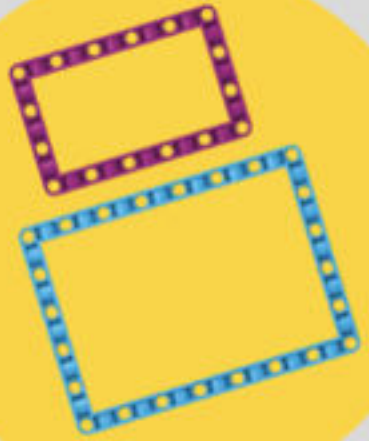
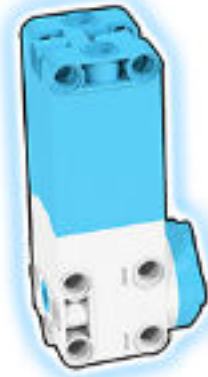
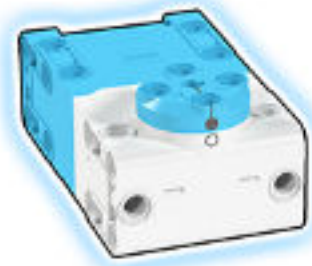



Discuss!

- What tasks can exoskeletons help with?
- What are the advantages of exoskeletons that mimic the structure of the human skeleton?
- In what films have you seen the use of robotic exoskeletons?
- How does a person walk? Why is it called controlled fall?
- What human organ is responsible for orientation in space?
- Robots can walk with or without weight transfer. How does your robot walk?
- How does maintaining the direction of the robot's torso work while walking?





Your achievements

Total:

0



1



2



3

```

when green flag clicked
  when green flag clicked
  set temp to 0
  repeat (10)
    when green flag clicked
    set temp to temp + 1
    wait 2000 milliseconds
    change temp by 1
  stop all programs
  
```



4



138

